

ENGINEERING
TOMORROW

Danfoss

Application guidelines

Inverter reciprocating compressors **VTZ**

R404A - R507 - R407C - R134a



<http://cc.danfoss.com>

Inverter compressors	5
Speed control.....	5
Advantages of speed control.....	5
Danfoss VTZ compressors with CD frequency converters	5
Compressor and frequency converter selection	6
Compressor size.....	6
Frequency converter variants	6
Nomenclature and specifications.....	7
Compressor nomenclature	7
Compressor specifications	7
Frequency converter nomenclature.....	7
Frequency converter general specifications	7
Operating conditions	8
Application envelope R404A/R507A.....	8
Speed range R404A/R507A.....	8
Application envelope R407C.....	9
Speed range R407C	9
Application envelope R134a	10
Speed range R134a.....	10
High and low pressure protection.....	11
Low ambient temperature operation	11
Electronic expansion valve	11
Short cycle timer function.....	12
Discharge gas temperature protection function	12
Discharge gas thermostat	12
Oil return management function	13
Approvals & certificates	14
Approvals and certificates.....	14
Pressure equipment directive 2014/68/EU	14
Low voltage directive 2014/35/EU.....	14
Machine directive 2014/30/EU	14
Internal free volume	14
Technical specifications	15
Dimensions	21
VTZ038 /VTZ054	21
VTZ086 /VTZ121	22
VTZ171 /VTZ215	23
Sight glass	24
Schrader.....	24
Suction & discharge connections.....	24
Frequency converter dimensions.....	24
Frequency converters Enclosures.....	27
Electrical data, connections and wiring.....	30
Compressor electrical specifications.....	30
Wiring & EMC protection	30
EMC correct installation of an IP20 frequency converter CD302	31
Wiring diagram.....	32
Fuses.....	33
Supply voltage.....	33
Wiring connections.....	34
Electrical connections.....	34
Soft-start control.....	35
Phase sequency and reverse rotation protection.....	35
IP rating	35
Motor protection	35
Voltage imbalance	35
Ambient temperature and altitude.....	35

System design recommendations	36
Piping design	36
Suction lines	36
Discharge line	37
Filter driers	37
Liquid refrigerant control and charge monitoring	37
Off-cycle migration	37
Liquid floodback during operation	37
Liquid floodback at change over cycles in reversible heat pumps	38
Liquid floodback and zeotropic refrigerants	38
Crankcase heater	38
Liquid line solenoid valve & pump-down	38
Suction accumulator	38
Vibration	39
Evaporator	39
Condenser	39
Defrosting using reverse cycle	39
Oil circulation rate and oil level management	40
Installation	41
System cleanliness	41
Compressor handling	41
Compressor mounting	41
Compressor connection to system	41
System pressure test	42
Leak detection	42
Vacuum pull-down moisture removal	42
Start-up	43
Refrigerant charging	43
Commissioning	44
Oil level checking and top-up	44
Suction gas superheat	44
Programming	44
Ordering information and packaging	45
Kit ordering and shipping	45
Packaging	45
Frequency converter single pack	45
Accessories	48
Valves, adapters, connectors & gaskets for use on suction and discharge connections	48
Crankcase heaters, soft starters, protection modules, thermostats & resistors	49
Lubricant , acoustic hoods and spareparts	49
Spare parts Frequency converter	50

Speed control

The introduction of speed control for refrigeration compressors is one of the major developments towards the optimization of refrigeration systems for the years to come. The capability of controlling speed is leading to a new approach in the design of refrigeration systems based on average load. For periods of

high cooling demand, the compressor speed can be increased which results in a higher refrigerant flow and thus higher cooling capacity. For periods of lower cooling demand, compressor speed can be decreased resulting in a lower cooling capacity.

Advantages of speed control

Smaller compressors can be selected than normally required with fixed speed compressors.

Energy savings are realized because the compressor speed is adapted to the actual cooling demand. The compressor power input is directly related to its speed. Further improvements can be achieved by adjusting the speed of other motors (fans, pumps, ...) to the actual needs.

Reduction of inrush current at start-up. The starting current is reduced to a value close to the nominal current.

Cooling process optimization. By continuously adapting the compressor speed to the actual needs, a more precise cooling process control is achieved.

Increased reliability. The number of on / off cycles is drastically decreased resulting in a reduction of mechanical and electrical stresses and wear, consequently improving the overall system reliability.

Reduced sound nuisance. At night, when cooling demand is usually low, the compressor speed can be decreased, contributing to lower system operating sound levels.

Danfoss VTZ compressors with CD frequency converters

Selecting the right frequency converter for a inverter refrigeration compressor can be very complex. Several parameters and characteristics have to be taken into account such as voltage, current, torque, heat generation, ramp-up, IP-rate, EMC and RFI.

For that reason, Danfoss has created pre-defined sets of VTZ compressors with dedicated CD302 frequency converters. All above mentioned

parameters have been taken into account during the design and test phase already. This is your guarantee that the compressor and frequency converter are fully compatible.

Of course these sets also simplify your selection considerably. And during commissioning the pre-programmed factory settings of the CD302 will save you valuable time.

Compressor size

Inverter technology offers more flexibility in compressor selection than fixed speed compressors. Selection of the right inverter compressor size can be done by different methods:

1. Maximum cooling capacity: Select a compressor size which achieves the peak load system cooling capacity demand at its maximum speed.
2. Nominal cooling capacity: Select a compressor size which achieves the nominal system cooling capacity at a rotational speed of 3600 – 4500 rpm (60-75 Hz).

3. Best Seasonal Efficiency Ratio: Select a compressor size which achieves the minimum system cooling demand at its minimum speed. Ensure that the compressor is able to cover the peak load system cooling capacity. This selection makes the compressor to run for a maximum of time at part load where the system efficiency is highest.

Simplified compressor performance tables can be found on following pages. For more complete performance data, please refer to the data sheets or to the calculation program.

Frequency converter variants

Different frequency converter variants are available according to:

1. IP class (CD302 frequency converters are available in IP20 / IP21 and IP55).
2. Local Control Panel (LCP) provided or not.

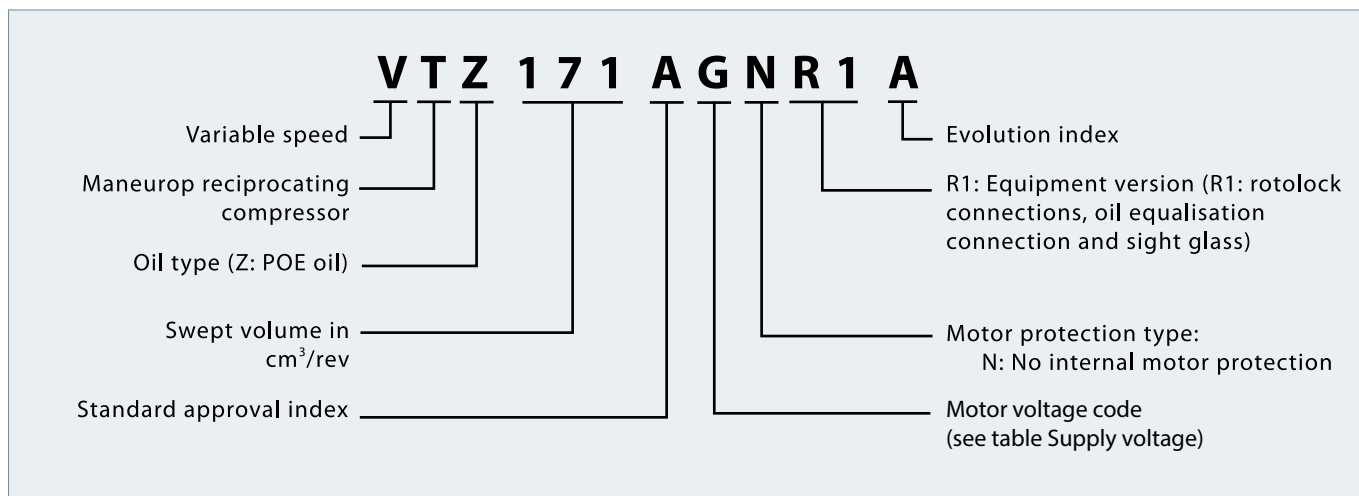
Compressor nomenclature

Compressor specifications

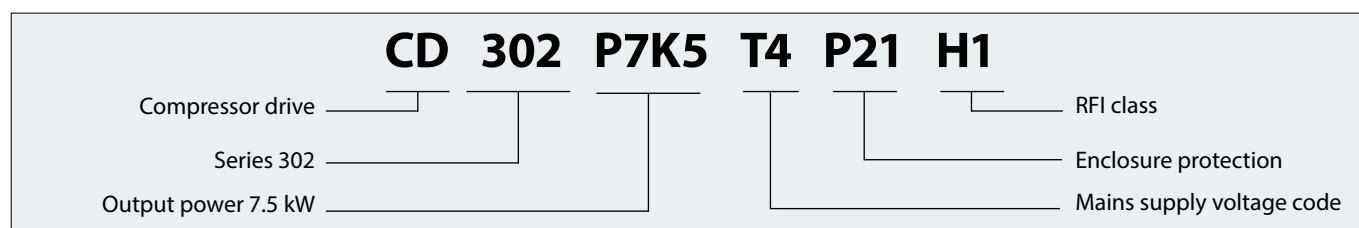
Compressor model	Swept volume (cm ³ /rev)	Displacement			Cyl. nbr	Oil charge (dm ³)	Net Weight (kg)
		Min speed (m ³ /h)	50 Hz (m ³ /h)	Max speed (m ³ /h)			
VTZ038	38.12	4.57	6.63	12.12	1	0.95	21
VTZ054	53.86	6.46	9.37	17.13	1	0.95	24
VTZ086	85.64	8.74	14.90	27.23	2	1.80	35
VTZ121	120.94	12.34	21.04	36.28	2	1.80	40
VTZ171	171.26	17.47	29.80	54.46	4	3.90	60
VTZ215	215.44	21.97	37.49	68.51	4	3.90	64

Frequency converter nomenclature

Frequency converter general specifications

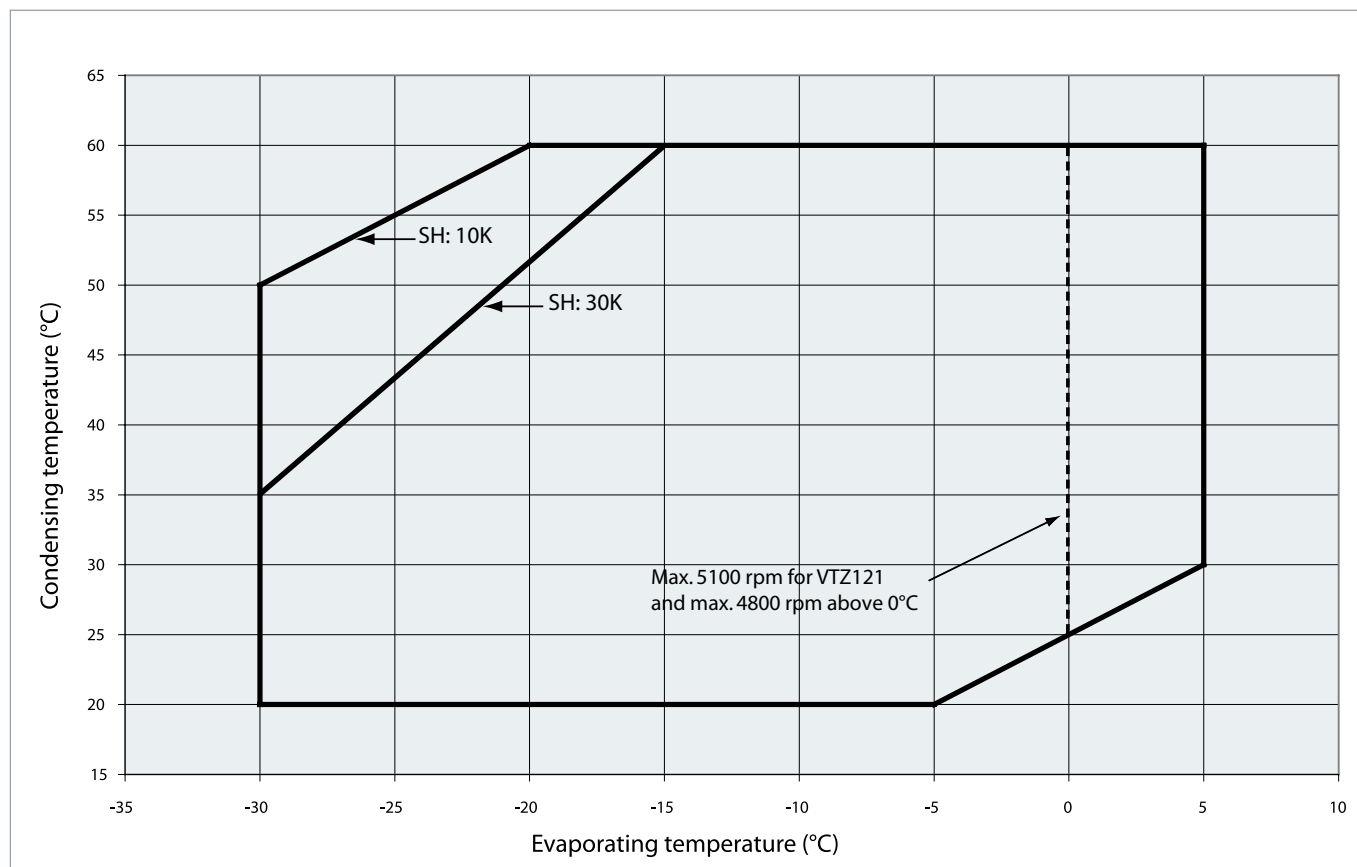
Mains supply voltage	T2: 200 - 240 V +/-10% (3-phase) T4: 380 - 480 V +/-10% (3-phase)
Supply frequency	50 / 60 Hz
Output voltage	0 - 100 % of supply voltage
Inputs	6 digital (0 - 24 V), 2 analogue (-10 / +10 V or 0 / 4 V -20 mA, scalable)
Programmable outputs	2 digital (0 - 24 V), 1 analogue, 2 relay
Protection functions	Over-current protection, over-modulation handling, low / high current handling
Control functions	Pump-down function, Anti short-cycle function, Oil return management
Communication	Modbus

Application envelope R404A/R507A



Speed range R404A/R507A

		Speed low limit	Speed high limit
1 cylinder	VTZ038	2100 rpm	5400 rpm
	VTZ054	2100 rpm	5400 rpm
2 cylinders	VTZ086	1800 rpm	5400 rpm
	VTZ121	1800 rpm	Tevap<0°C: 5100 rpm Tevap>0°C: 4800 rpm
4 cylinders	VTZ171	1800 rpm	5400 rpm
	VTZ215	1800 rpm	5400 rpm

**Application envelope
R407C**

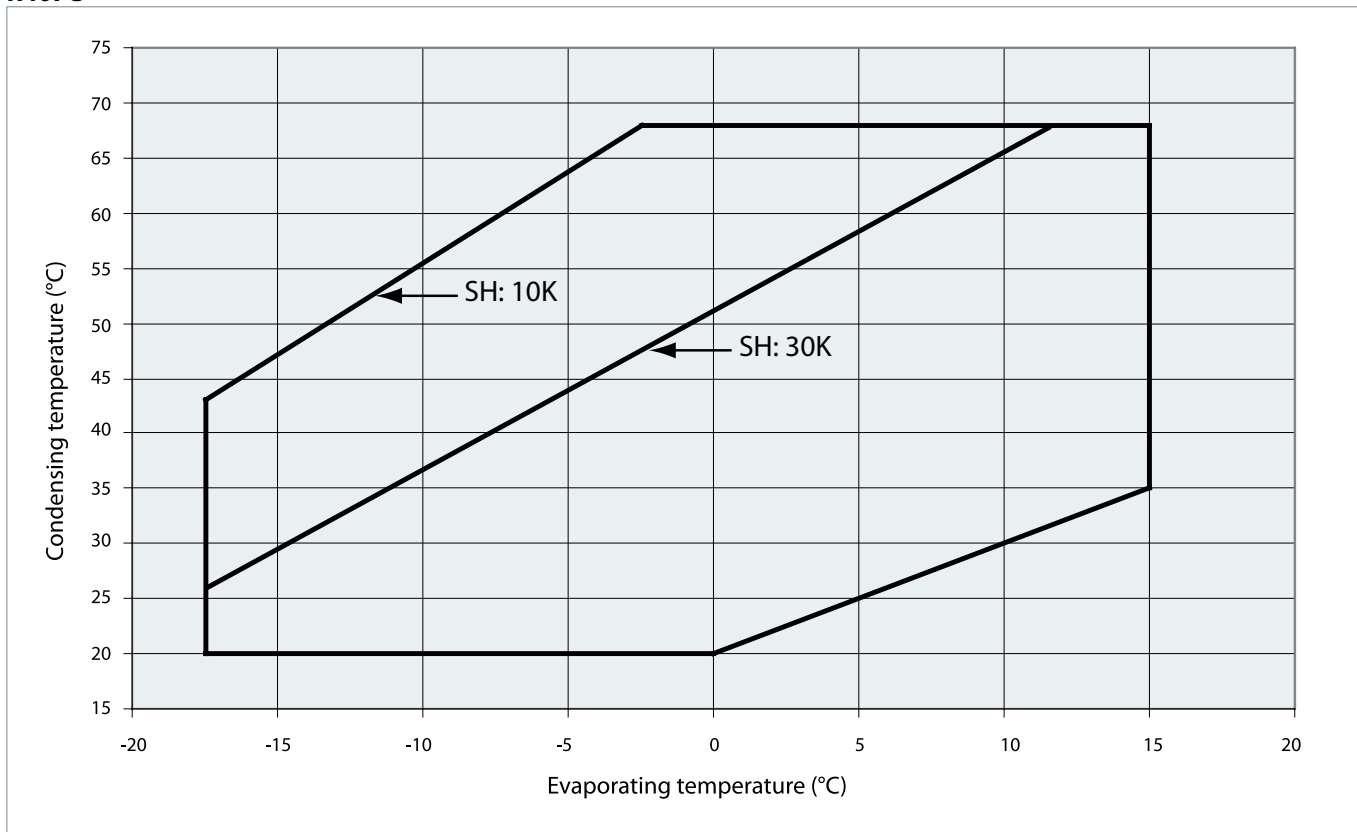

Speed range R407C

		Speed low limit	Speed high limit
1 cylinder	VTZ038	2100 rpm	5400 rpm
	VTZ054	2100 rpm	5400 rpm
2 cylinders	VTZ086	1800 rpm	5400 rpm
	VTZ121	1800 rpm	5100 rpm
4 cylinders	VTZ171	1800 rpm	5400 rpm
	VTZ215	1800 rpm	5400 rpm

**Application envelope
R134a**

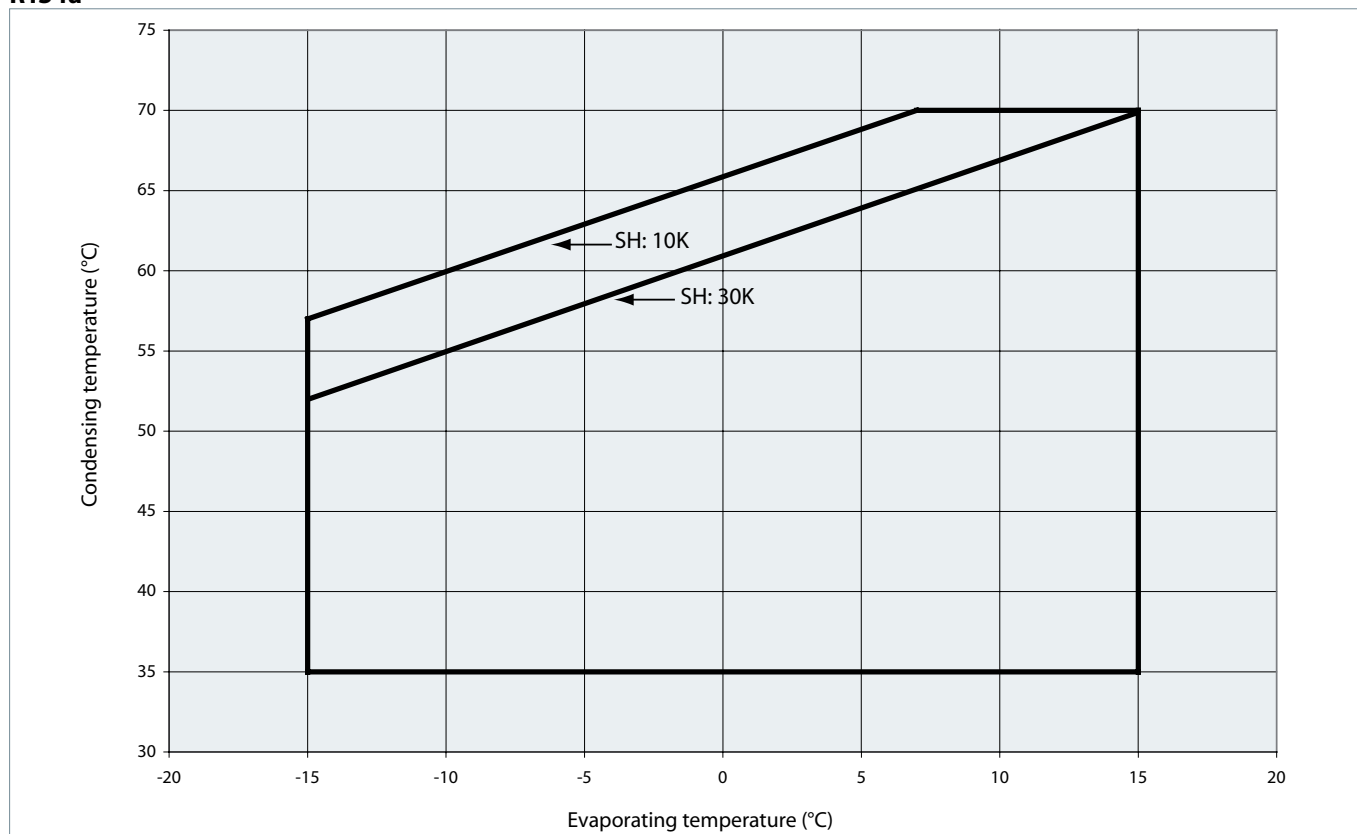

Speed range R134a

		Speed low limit	Speed high limit
1 cylinder	VTZ038	2100 rpm	5400 rpm
	VTZ054	2100 rpm	5400 rpm
2 cylinders	VTZ086	1800 rpm	5400 rpm
	VTZ121	1800 rpm	5100 rpm
4 cylinders	VTZ171	1800 rpm	5400 rpm
	VTZ215	1800 rpm	5400 rpm

Application Guidelines

Operating conditions

High and low pressure protection

A high pressure safety switch is required to stop the compressor, should the discharge pressure exceed the values shown in the table below. The high pressure switch can be set to lower values depending on the application and ambient conditions. The HP switch must either be in a

lockout circuit, or be a manual reset device to prevent compressor cycling around the high pressure limit. When a discharge valve is used, the HP switch must be connected to the service valve gauge port, which cannot be isolated.

	R407C	R134a	R404A
Working pressure range high side bar (g)	7.8 - 29.4	7.9 - 20.2	9.9 - 27.7
Working pressure range low side bar (g)	1.4 - 6.6	0.6 - 3.9	1 - 6.1

A low pressure safety switch is recommended to avoid compressor operation at too lower suction pressures.

Low ambient temperature operation

At low ambient temperatures, the condensing temperature and condensing pressure in air cooled condensers will decrease.

which can introduce other problems. A non-return valve in the discharge line is required and special care should be taken when designing the discharge line.).

This low pressure may be insufficient to supply enough liquid refrigerant to the evaporator. As a result the evaporator temperature will strongly decrease with the risk of frosting. At compressor start-up, the compressor can pull a deep vacuum and it can be switched off by the low pressure protection. Depending on the low pressure switch setting and delay timer, short cycling can occur. To avoid these problems, several solutions are possible, based on reducing condenser capacity:

Other problems can also occur when the compressor is operating at low ambient temperature. During shut down periods, liquid refrigerant can migrate to a cold compressor.

- Reduce air flow to condensers.
- Indoor location of condensers
- Liquid flooding of condensers (note: this solution requires extra refrigerant charge,

For such conditions a belt-type crankcase heater is strongly recommended.

Note that with 100% suction gas cooled motors, Maneurop® compressors can be externally insulated.

Refer to section «Liquid refrigerant migration & charge limits» for more details.

Electronic expansion valve

With variable capacity systems, an electronic expansion valve (EXV) is one of the better solutions to handle refrigerant mass flow variations. Ramp-up and ramp-down settings, of both EXV and compressor, must be done with great care.

to a certain degree, before the start up of the compressor.

Ramp-up of the EXV must be shorter than the ramp-up of the compressor, to avoid any low pressure operation on suction side of the compressor. The EXV can also be opened, up

Ramp-down of the EXV must be longer than the ramp-down of the compressor, also to avoid low pressure operation (except with pump-down).

The EXV should be closed, and remain closed, when the compressor is off, to avoid any liquid refrigerant entering the compressor.

Short cycle timer function

Short cycle control is directly provided by the CD302 frequency converter, when parameter 28.0* is enabled.

The function is factory set to enabled, with minimum running time 12 seconds and interval between starts 300 seconds.

Short cycle settings are accessible in parameter 28.0* list, in the "compressor functions" menu.

Discharge gas temperature protection function

A discharge temperature monitor function can be enabled in the frequency converter. All settings are available in parameter list 28.2*.

They are factory preset as follow:

- 28.20: [0] none - temperature source (sensor input)
- 28.21: [60] °C - temperature unit
- 28.24: 130 - warning level
- 28.25: [1] decrease cooling - warning action
- 28.26: 145 - emergency level
- 28.27: is the actual discharge temperature measured by the sensor.

To activate the discharge temperature monitor function, with the factory setting, the only modification required is to connect the sensor to Analog Input 54 (4.20 mA) between 13 and 54, and set the parameter 28.20 to "[2] Analog input 54". When the warning level is reached, "decrease cooling" action starts by decreasing the compressor speed by steps of 600 rpm (10 Hz) every 3 minutes until the temperature, either drops below the level, programmed in parameter 28.24 (warning level) or exceed the level programmed in parameter 28.26 (emergency level). When the emergency level is reached, the compressor is stopped and the frequency converter shows an "alarm".

Discharge gas thermostat

Discharge gas temperature (DGT) protection is required if the high and low pressure switch settings do not protect the compressor against operations beyond its specific application envelope.

The compressor must not be allowed to cycle on the discharge gas thermostat. Continuous operations beyond the compressor's operating range will cause serious damage to the compressor!

The discharge gas temperature must not exceed 135°C.

A DGT accessory is available from Danfoss: refer to accessories pages at the end of this document.

A discharge gas temperature protection device must be installed on all heat pumps. In reversible air-to-air and air-to-water heat pumps the discharge temperature must be monitored during development test by the equipment manufacturer.

The discharge gas thermostat accessory kit (code no.7750009) includes all components required for installation, as shown below. The thermostat must be attached to the discharge line within 150 mm from the compressor discharge port and must be thermally insulated and tightly fixed on the pipe.

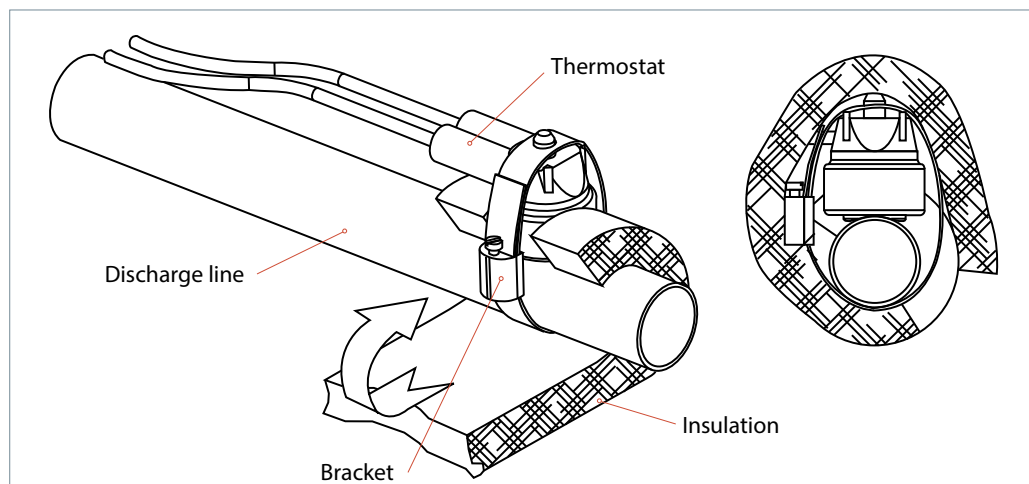

Oil return management function

Insufficient oil level can be the result of oil depositing itself in pipes and heat exchangers. The oil deposit can be returned to the crankcase, by increasing velocity for short period, at regular time intervals or when velocity is too low to ensure adequate oil returns.

With oil return management these two oil return mechanisms can be programmed in the CD302.

With oil return management function enabled, the CD302 performs oil return by boosting the compressor speed to 4200 rpm (70 Hz) for a selectable duration as programmed in parameter 28.13. The boosts are performed at fixed time intervals (as programmed in parameter 28.12) or if the compressor speed has been less than 3000 rpm (50 Hz) for too long (as programmed in 28.11) which ever occurs first. Thus the maximum time between two consecutive oil return boosts is programmed in 28.12.

Approvals and certificates

VTZ Compressor with CD302 frequency converter comply with the following approvals and certificates.

Certificates are listed on the product datasheets: <http://www.danfoss.com/odsg>

CE0062 or CE0038 (European Directive)		All models
UL (Underwriters Laboratories)		All models
EMC 2014/30/EU		All models

Pressure equipment directive 2014/68/EU

Product	VTZ038-054	VTZ086-121-171-215-242
Fluids	Group 2	
PED Category	I	II
Evaluation module	no scope	D1
TS - Service temperature LP	50°C > Ts > -35°C	
PS - Service pressure LP	22,6 bar(g)	

Low voltage directive 2014/35/EU

Product	VTZ038-215
Declaration of conformity	Contact Danfoss

Machine directive 2014/30/EU

Product	VTZ038-215
Manufacturer's declaration of incorporation	Contact Danfoss

Internal free volume

Product	Internal free volume at LP side (litre)	High side (litre)
VTZ038-054	7.7	0.28
VTZ086-121	16.5	0.63
VTZ171-215	32	1.20

Performance data
R404A

		To	-30		-25		-20		-15		-10		-5		0		5	
		Tc	Qo	Pe	Qo	Pe	Qo	Pe	Qo	Pe	Qo	Pe	Qo	Pe	Qo	Pe	Qo	Pe
VTZ038																		
Min rpm	20	1 090	0.61	1 430	0.67	1 850	0.71	2 350	0.74	2 950	0.76	3 650	0.77	-	-	-	-	-
	30	840	0.64	1 130	0.72	1 480	0.79	1 910	0.85	2 420	0.89	3 030	0.93	3 730	0.95	4 550	0.96	-
	40	610	0.64	850	0.75	1 140	0.85	1 500	0.94	1 920	1.02	2 430	1.09	3 030	1.14	3 730	1.18	-
	50	400	0.62	590	0.76	830	0.90	1 110	1.02	1 450	1.14	1 860	1.24	2 350	1.32	2 930	1.40	-
3600 rpm	20	1 720	1.08	2 290	1.19	3 000	1.29	3 860	1.37	4 890	1.43	6 110	1.45	-	-	-	-	-
	30	1 380	1.10	1 920	1.26	2 570	1.40	3 360	1.52	4 290	1.62	5 400	1.69	6 690	1.74	8 190	1.75	-
	40	1 020	1.10	1 490	1.30	2 070	1.49	2 760	1.66	3 580	1.81	4 560	1.93	5 700	2.03	7 040	2.11	-
	50	640	1.04	1 040	1.29	1 520	1.52	2 100	1.75	2 800	1.95	3 630	2.14	4 610	2.30	5 760	2.44	-
Max rpm	20	2 200	1.75	3 080	2.01	4 160	2.22	5 450	2.39	6 990	2.51	8 790	2.57	-	-	-	-	-
	30	1 680	1.74	2 480	2.08	3 460	2.38	4 640	2.64	6 030	2.86	7 650	3.03	9 550	3.15	11 730	3.22	-
	40	1 140	1.60	1 860	2.03	2 710	2.43	3 740	2.78	4 960	3.10	6 400	3.37	8 070	3.60	10 010	3.78	-
	50	630	1.34	1 230	1.85	1 940	2.34	2 800	2.79	3 830	3.21	5 050	3.58	6 480	3.92	8 150	4.20	-
60	-	-	-	-	1 190	2.11	1 860	2.66	2 670	3.17	3 640	3.65	4 810	4.09	6 190	4.49	-	
VTZ054																		
Min rpm	20	1 480	0.88	1 970	0.97	2 590	1.05	3 370	1.11	4 310	1.16	5 450	1.18	-	-	-	-	-
	30	1 180	0.94	1 600	1.05	2 120	1.16	2 770	1.26	3 570	1.34	4 540	1.40	5 700	1.45	7 060	1.48	-
	40	920	0.96	1 260	1.11	1 690	1.25	2 220	1.38	2 890	1.50	3 700	1.60	4 670	1.69	5 820	1.76	-
	50	680	0.96	950	1.14	1 290	1.32	1 710	1.49	2 240	1.64	2 890	1.79	3 680	1.92	4 640	2.03	-
3600 rpm	20	2 520	1.58	3 300	1.75	4 270	1.91	5 450	2.05	6 870	2.16	8 550	2.26	-	-	-	-	-
	30	2 120	1.67	2 840	1.88	3 720	2.09	4 790	2.28	6 070	2.44	7 590	2.59	9 380	2.72	11 450	2.82	-
	40	1 660	1.69	2 300	1.96	3 070	2.22	4 010	2.46	5 130	2.69	6 460	2.90	8 030	3.09	9 870	3.25	-
	50	1 190	1.64	1 720	1.97	2 360	2.29	3 130	2.60	4 070	2.89	5 190	3.17	6 520	3.42	8 090	3.66	-
Max rpm	20	3 740	2.45	4 870	2.76	6 250	3.06	7 910	3.34	9 880	3.61	12 210	3.84	-	-	-	-	-
	30	2 970	2.47	4 010	2.84	5 270	3.21	6 780	3.57	8 580	3.92	10 710	4.26	13 190	4.58	16 070	4.87	-
	40	2 170	2.43	3 090	2.84	4 190	3.28	5 520	3.72	7 110	4.15	9 000	4.59	11 210	5.02	13 800	5.43	-
	50	1 410	2.30	2 150	2.77	3 070	3.26	4 170	3.77	5 510	4.29	7 120	4.82	9 040	5.35	11 290	5.87	-
60	-	-	-	-	1 950	3.15	2 800	3.73	3 850	4.32	5 150	4.94	6 720	5.56	8 600	6.19	-	
VTZ086																		
Min rpm	20	1 840	1.18	2 580	1.31	3 520	1.42	4 660	1.49	6 030	1.54	7 650	1.56	-	-	-	-	-
	30	1 340	1.21	1 950	1.40	2 720	1.56	3 660	1.69	4 800	1.80	6 160	1.87	7 750	1.92	9 600	1.94	-
	40	930	1.16	1 420	1.42	2 040	1.66	2 800	1.85	3 720	2.02	4 830	2.16	6 140	2.27	7 670	2.35	-
	50	580	1.04	980	1.38	1 460	1.69	2 050	1.97	2 770	2.21	3 650	2.42	4 690	2.60	5 920	2.75	-
3600 rpm	20	4 290	2.46	5 790	2.74	7 620	2.97	9 820	3.15	12 430	3.29	15 490	3.38	-	-	-	-	-
	30	3 260	2.53	4 590	2.91	6 200	3.25	8 140	3.54	10 440	3.78	13 140	3.96	16 290	4.10	19 910	4.18	-
	40	2 290	2.46	3 430	2.97	4 810	3.42	6 470	3.82	8 440	4.17	10 770	4.47	13 500	4.71	16 650	4.91	-
	50	1 400	2.24	2 340	2.87	3 460	3.45	4 820	3.98	6 450	4.46	8 390	4.88	10 680	5.25	13 360	5.56	-
Max rpm	20	6 160	3.89	8 310	4.34	10 950	4.74	14 130	5.09	17 890	5.40	22 290	5.66	-	-	-	-	-
	30	4 960	4.00	6 910	4.59	9 290	5.13	12 130	5.61	15 490	6.05	19 410	6.44	23 940	6.78	29 120	7.07	-
	40	3 640	3.91	5 360	4.66	7 440	5.35	9 920	5.99	12 830	6.58	16 250	7.11	20 190	7.60	24 730	8.03	-
	50	2 260	3.59	3 720	4.51	5 470	5.38	7 540	6.19	9 980	6.94	12 850	7.64	16 190	8.28	20 040	8.87	-
60	-	-	-	-	3 420	5.16	5 060	6.15	6 990	7.08	9 280	7.96	11 970	8.78	15 110	9.55	-	
VTZ121																		
Min rpm	20	2 750	1.89	3 660	2.05	4 810	2.19	6 230	2.30	7 940	2.39	9 980	2.46	-	-	-	-	-
	30	2 280	2.03	3 110	2.25	4 130	2.43	5 390	2.60	6 900	2.74	8 710	2.85	10 840	2.95	13 320	3.02	-
	40	1 770	2.10	2 480	2.38	3 360	2.64	4 430	2.86	5 730	3.06	7 280	3.24	9 120	3.39	11 280	3.51	-
	50	1 230	2.08	1 810	2.44	2 520	2.77	3 390	3.07	4 450	3.35	5 730	3.59	7 250	3.81	9 060	4.01	-
3600 rpm	20	5 530	3.69	7 470	4.09	9 890	4.47	12 850	4.84	16 410	5.21	20 620	5.56	-	-	-	-	-
	30	4 500	3.88	6 220	4.35	8 360	4.82	10 990	5.26	14 150	5.70	17 900	6.12	22 300	6.54	27 410	6.96	-
	40	3 530	3.99	4 980	4.56	6 800	5.11	9 040	5.64	11 760	6.17	15 020	6.68	18 860	7.18	23 360	7.68	-
	50	2 630	4.00	3 770	4.68	5 230	5.33	7 040	5.97	9 280	6.60	11 990	7.21	15 230	7.81	19 070	8.41	-
Max rpm	20	8 060	5.47	10 760	6.11	14 150	6.73	18 330	7.32	23 400	7.85	29 440	8.31	-	-	-	-	-
	30	6 400	5.63	8 760	6.38	11 710	7.14	15 340	7.90	19 750	8.64	25 040	9.34	31 310	9.99	36 440	9.82	-
	40	4 870	5.67	6 870	6.50	9 350	7.38	12 420	8.29	16 170	9.20	20 690	10.10	26 100	10.99	30 720	10.95	-
	50	3 450	5.64	5 070	6.53	7 080	7.49	9 560	8.51	12 630	9.57	16 370	10.65	20 890	11.74	24 920	11.89	-
60	-	-	-	-	4 860	7.52	6 750	8.62	9 120	9.79	12 070	11.02	15 690	12.29	19 050	12.65	-	

Performance data

R404A

	To	-30		-25		-20		-15		-10		-5		0		5	
	Tc	Qo	Pe	Qo	Pe	Qo	Pe	Qo	Pe	Qo	Pe	Qo	Pe	Qo	Pe	Qo	Pe
VTZ171																	
Min rpm	20	3 900	2.31	5 360	2.59	7 180	2.83	9 400	3.04	12 050	3.20	15 160	3.31	-	-	-	-
	30	2 920	2.32	4 150	2.65	5 680	2.96	7 550	3.24	9 790	3.47	12 450	3.67	15 540	3.82	19 120	3.91
	40	2 090	2.31	3 090	2.72	4 340	3.11	5 870	3.47	7 720	3.81	9 910	4.10	12 500	4.36	15 500	4.57
	50	1 380	2.23	2 170	2.74	3 140	3.23	4 340	3.70	5 790	4.14	7 540	4.56	9 620	4.94	12 070	5.28
3600 rpm	20	-	-	-	-	2 070	3.24	2 940	3.84	4 010	4.41	5 320	4.97	6 900	5.49	8 790	5.98
	30	7 670	4.52	10 390	5.12	13 830	5.66	18 060	6.16	23 160	6.61	29 220	7.03	-	-	-	-
	40	6 220	4.73	8 660	5.49	11 700	6.16	15 400	6.77	19 870	7.32	25 170	7.82	31 380	8.28	38 600	8.71
	50	4 700	4.78	6 840	5.74	9 450	6.61	12 620	7.39	16 430	8.08	20 960	8.71	26 280	9.28	32 490	9.80
Max rpm	20	3 110	4.54	4 930	5.76	7 100	6.87	9 720	7.87	12 860	8.77	16 600	9.58	21 020	10.31	26 200	10.98
	30	-	-	-	-	4 660	6.81	6 710	8.08	9 160	9.24	12 090	10.29	15 590	11.24	19 740	12.10
	40	11 310	7.31	15 890	8.35	21 460	9.26	28 030	10.05	35 630	10.73	44 290	11.32	-	-	-	-
	50	8 920	7.54	12 990	8.95	17 920	10.20	23 720	11.32	30 410	12.32	38 030	13.21	46 580	14.03	56 090	14.77
VTZ215	20	6 400	7.24	9 960	9.03	14 240	10.66	19 260	12.14	25 040	13.50	31 610	14.73	38 980	15.87	47 190	16.93
	30	3 750	6.29	6 790	8.51	10 420	10.55	14 660	12.43	19 520	14.17	25 040	15.78	31 230	17.28	38 110	18.69
	40	-	-	-	-	6 470	9.78	9 910	12.09	13 850	14.25	18 310	16.27	23 310	18.16	28 870	19.95
	50	-	-	-	-	-	-	-	-	-	-	-	-	-	-	-	-
Min rpm	20	4 790	3.00	6 690	3.31	9 050	3.58	11 940	3.79	15 400	3.95	19 490	4.04	-	-	-	-
	30	3 700	3.18	5 330	3.60	7 350	3.97	9 820	4.30	12 800	4.57	16 320	4.79	20 450	4.94	25 240	5.02
	40	2 690	3.24	4 070	3.78	5 760	4.28	7 820	4.74	10 310	5.15	13 270	5.51	16 750	5.80	20 820	6.03
	50	1 750	3.15	2 880	3.83	4 250	4.48	5 910	5.08	7 910	5.65	10 320	6.16	13 170	6.62	16 530	7.02
3600 rpm	20	-	-	-	-	2 800	4.52	4 060	5.30	5 600	6.03	7 450	6.72	9 670	7.36	12 330	7.95
	30	9 250	5.45	12 750	6.26	17 190	7.01	22 690	7.68	29 370	8.27	37 360	8.76	-	-	-	-
	40	7 600	5.86	10 700	6.85	14 570	7.79	19 340	8.68	25 130	9.49	32 060	10.23	40 260	10.86	49 840	11.38
	50	5 910	6.12	8 600	7.28	11 900	8.41	15 940	9.49	20 840	10.53	26 720	11.49	33 700	12.38	41 900	13.16
Max rpm	20	4 130	6.24	6 420	7.55	9 160	8.85	12 470	10.13	16 470	11.37	21 290	12.56	27 050	13.68	33 880	14.72
	30	-	-	-	-	6 270	9.13	8 850	10.58	11 970	12.02	15 740	13.41	20 280	14.76	25 730	16.04
	40	15 190	9.71	20 520	11.10	27 020	12.40	34 830	13.62	44 110	14.73	54 990	15.73	-	-	-	-
	50	12 240	9.94	17 180	11.64	23 160	13.30	30 300	14.90	38 760	16.44	48 670	17.91	60 180	19.30	73 430	20.59
	20	9 030	9.79	13 430	11.78	18 700	13.76	25 000	15.73	32 450	17.67	41 210	19.58	51 430	21.44	63 230	23.24
	30	5 820	9.21	9 480	11.45	13 880	13.73	19 140	16.03	25 420	18.35	32 860	20.66	41 600	22.97	51 780	25.26
	40	-	-	-	-	8 910	13.17	12 970	15.77	17 900	18.43	23 830	21.13	30 910	23.85	39 290	26.60
	50	-	-	-	-	-	-	-	-	-	-	-	-	-	-	-	-

To: Evaporating temperature in °C
Superheat = 10 K

Tc: Condensing temperature in °C
Subcooling = 0 K

Qo: Cooling capacity in W

Pe: Power input in kW

Min rpm: Minimum rotation speed

3600 rpm: Rotation speed 3600 rpm

Max rpm: Maximum rotation speed

Performance data
R407C

	To	-17.5		-15		-10		-5		0		5		10		15	
	Tc	Qo	Pe	Qo	Pe	Qo	Pe	Qo	Pe	Qo	Pe	Qo	Pe	Qo	Pe	Qo	Pe
VTZ038																	
Min rpm	20	1 780	0.66	2 030	0.68	2 610	0.71	3 310	0.72	4 140	0.72	-	-	-	-	-	-
	30	1 460	0.73	1 690	0.77	2 200	0.84	2 820	0.89	3 560	0.91	4 420	0.93	5 430	0.93	-	-
	40	1 150	0.76	1 340	0.82	1 790	0.93	2 330	1.01	2 980	1.08	3 730	1.13	4 620	1.17	5 640	1.20
	50	-	-	-	-	1 390	0.98	1 860	1.11	2 400	1.22	3 050	1.32	3 810	1.40	4 700	1.47
	60	-	-	-	-	-	-	1 390	1.18	1 840	1.34	2 390	1.48	3 030	1.61	3 780	1.73
3600 rpm	20	2 750	1.07	3 170	1.11	4 170	1.19	5 400	1.25	6 900	1.30	-	-	-	-	-	-
	30	2 330	1.17	2 700	1.24	3 580	1.35	4 650	1.45	5 960	1.53	7 530	1.59	9 390	1.63	-	-
	40	1 910	1.25	2 240	1.33	3 010	1.49	3 940	1.63	5 070	1.75	6 430	1.86	8 040	1.94	9 930	2.00
	50	-	-	-	-	2 440	1.60	3 250	1.79	4 220	1.96	5 370	2.11	6 740	2.25	8 370	2.36
	60	-	-	-	-	-	-	2 550	1.91	3 370	2.14	4 330	2.35	5 490	2.54	6 860	2.71
Max rpm	20	4 050	1.68	4 620	1.79	5 970	2.00	7 650	2.19	9 720	2.35	-	-	-	-	-	-
	30	3 440	1.82	3 970	1.96	5 200	2.22	6 720	2.47	8 580	2.70	10 850	2.90	13 580	3.08	-	-
	40	2 780	1.91	3 260	2.06	4 360	2.37	5 700	2.68	7 350	2.98	9 360	3.26	11 790	3.51	14 700	3.73
	50	-	-	-	-	3 480	2.49	4 650	2.85	6 070	3.21	7 810	3.55	9 930	3.88	12 480	4.18
	60	-	-	-	-	-	-	3 580	2.98	4 760	3.40	6 230	3.81	8 020	4.21	10 210	4.59
VTZ054																	
Min rpm	20	2 350	0.87	2 680	0.90	3 460	0.94	4 400	0.97	5 530	0.99	-	-	-	-	-	-
	30	1 980	0.99	2 280	1.03	2 970	1.11	3 820	1.17	4 840	1.21	6 040	1.24	7 460	1.26	-	-
	40	1 590	1.06	1 850	1.13	2 460	1.26	3 190	1.36	4 080	1.44	5 150	1.51	6 400	1.56	7 870	1.60
	50	-	-	-	-	1 930	1.37	2 550	1.53	3 300	1.67	4 210	1.78	5 300	1.88	6 580	1.96
	60	-	-	-	-	-	-	1 910	1.65	2 520	1.86	3 270	2.04	4 170	2.20	5 250	2.33
3600 rpm	20	4 080	1.59	4 690	1.66	6 120	1.79	7 840	1.90	9 900	1.99	-	-	-	-	-	-
	30	3 420	1.73	3 960	1.82	5 240	2.00	6 800	2.16	8 680	2.32	10 890	2.45	13 480	2.58	-	-
	40	2 810	1.85	3 270	1.96	4 370	2.19	5 740	2.41	7 400	2.62	9 380	2.83	11 720	3.02	14 440	3.20
	50	-	-	-	-	3 560	2.33	4 700	2.62	6 120	2.89	7 840	3.16	9 900	3.43	12 330	3.68
	60	-	-	-	-	-	-	3 740	2.76	4 880	3.10	6 320	3.45	8 070	3.79	10 170	4.13
Max rpm	20	5 770	2.54	6 620	2.70	8 650	3.01	11 180	3.28	14 300	3.51	-	-	-	-	-	-
	30	4 910	2.72	5 670	2.92	7 460	3.32	9 680	3.70	12 420	4.05	15 750	4.37	19 760	4.63	-	-
	40	4 080	2.81	4 740	3.05	6 290	3.53	8 220	4.01	10 590	4.48	13 490	4.93	17 000	5.33	21 180	5.69
	50	-	-	-	-	5 160	3.63	6 800	4.20	8 810	4.78	11 290	5.35	14 300	5.89	17 920	6.41
	60	-	-	-	-	-	-	5 410	4.26	7 080	4.93	9 140	5.62	11 670	6.29	14 740	6.96
VTZ086																	
Min rpm	20	3 140	1.10	3 680	1.14	4 970	1.19	6 550	1.22	8 450	1.24	-	-	-	-	-	-
	30	2 410	1.28	2 860	1.34	3 900	1.45	5 180	1.53	6 720	1.58	8 560	1.62	10 730	1.65	-	-
	40	1 800	1.36	2 180	1.47	3 050	1.66	4 100	1.81	5 350	1.93	6 850	2.02	8 610	2.09	10 670	2.14
	50	-	-	-	-	2 320	1.78	3 200	2.03	4 240	2.23	5 450	2.40	6 880	2.53	8 550	2.63
	60	-	-	-	-	-	-	2 390	2.13	3 270	2.45	4 280	2.71	5 440	2.93	6 790	3.12
3600 rpm	20	5 300	2.51	6 290	2.61	8 630	2.76	11 470	2.88	14 850	2.96	-	-	-	-	-	-
	30	4 570	2.72	5 470	2.86	7 560	3.10	10 070	3.28	13 040	3.42	16 520	3.53	20 550	3.62	-	-
	40	3 750	2.83	4 570	3.04	6 440	3.40	8 640	3.69	11 220	3.92	14 220	4.10	17 690	4.25	21 670	4.38
	50	-	-	-	-	5 220	3.61	7 140	4.04	9 350	4.40	11 900	4.69	14 830	4.94	18 190	5.16
	60	-	-	-	-	-	-	5 520	4.27	7 390	4.80	9 510	5.24	11 930	5.63	14 690	5.96
Max rpm	20	8 900	3.71	10 190	3.86	13 360	4.11	17 450	4.31	22 630	4.44	-	-	-	-	-	-
	30	7 760	4.13	8 850	4.33	11 490	4.69	14 870	5.02	19 150	5.30	24 510	5.52	31 120	5.65	-	-
	40	6 700	4.48	7 660	4.72	9 910	5.19	12 710	5.65	16 230	6.07	20 650	6.45	26 130	6.76	32 830	7.00
	50	-	-	-	-	8 430	5.62	10 790	6.19	13 690	6.75	17 300	7.28	21 790	7.77	27 320	8.21
	60	-	-	-	-	-	-	8 910	6.66	11 330	7.35	14 270	8.03	17 900	8.69	22 400	9.31
VTZ121																	
Min rpm	20	4 520	1.58	5 230	1.66	6 890	1.77	8 890	1.84	11 260	1.85	-	-	-	-	-	-
	30	3 740	1.80	4 370	1.91	5 840	2.10	7 600	2.25	9 710	2.35	12 180	2.40	15 060	2.39	-	-
	40	2 990	1.96	3 550	2.11	4 830	2.39	6 370	2.62	8 200	2.80	10 360	2.94	12 890	3.02	15 820	3.04
	50	-	-	-	-	3 870	2.63	5 180	2.94	6 750	3.21	8 610	3.43	10 780	3.60	13 320	3.71
	60	-	-	-	-	-	-	4 070	3.23	5 370	3.58	6 910	3.89	8 740	4.15	10 890	4.35
3600 rpm	20	9 710	3.77	11 090	3.93	14 290	4.27	18 160	4.60	22 770	4.92	-	-	-	-	-	-
	30	8 140	4.01	9 370	4.21	12 240	4.60	15 720	4.98	19 890	5.34	24 820	5.69	30 590	6.03	-	-
	40	6 670	4.27	7 750	4.52	10 270	5.01	13 350	5.47	17 060	5.93	21 470	6.36	26 670	6.77	32 730	7.16
	50	-	-	-	-	8 420	5.36	11 070	5.97	14 290	6.55	18 170	7.11	22 770	7.64	28 190	8.15
	60	-	-	-	-	-	-	8 900	6.33	11 620	7.09	14 940	7.82	18 940	8.51	23 680	9.18
Max rpm	20	13 480	5.40	15 370	5.71	19 760	6.33	25 030	6.98	31 290	7.64	-	-	-	-	-	-
	30	11 420	5.76	13 130	6.10	17 100	6.81	21 900	7.52	27 610	8.26	34 340	9.02	42 180	9.79	-	-
	40	9 440	6.08	10 940	6.48	14 430	7.28	18 690	8.09	23 800	8.92	29 860	9.77	36 960	10.64	45 210	11.52
	50	-	-	-	-	11 850	7.68	15 500	8.61	19 940	9.56	25 270	10.53	31 570	11.51	38 950	12.51
	60	-	-	-	-	-	-	12 430	9.03	16 140	10.13	20 670	11.23	26 120	12.35	32 570	13.49

Performance data
R407C

	To	-17.5		-15		-10		-5		0		5		10		15	
	Tc	Qo	Pe	Qo	Pe	Qo	Pe	Qo	Pe	Qo	Pe	Qo	Pe	Qo	Pe	Qo	Pe
VTZ171																	
Min rpm	20	5 980	2.20	6 880	2.27	9 030	2.38	11 660	2.45	14 850	2.47	-	-	-	-	-	-
	30	5 120	2.57	5 960	2.68	7 920	2.88	10 330	3.05	13 240	3.17	16 710	3.24	20 810	3.27	-	-
	40	4 150	2.83	4 890	3.00	6 630	3.31	8 760	3.59	11 350	3.84	14 460	4.03	18 140	4.19	22 460	4.28
	50	-	-	-	-	5 250	3.64	7 060	4.05	9 280	4.44	11 970	4.78	15 180	5.08	18 990	5.33
	60	-	-	-	-	-	5 310	4.38	7 120	4.93	9 340	5.44	12 040	5.92	15 290	6.34	-
3600 rpm	20	13 400	4.86	15 260	5.05	19 570	5.33	24 760	5.49	30 920	5.50	-	-	-	-	-	-
	30	11 210	5.37	12 930	5.67	16 910	6.18	21 710	6.59	27 450	6.88	34 220	7.02	42 140	7.00	-	-
	40	9 010	5.66	10 540	6.06	14 110	6.82	18 450	7.49	23 670	8.06	29 890	8.50	37 190	8.80	45 700	8.93
	50	-	-	-	-	11 300	7.25	15 090	8.19	19 720	9.04	25 290	9.80	31 900	10.42	39 670	10.91
	60	-	-	-	-	-	11 760	8.69	15 710	9.84	20 550	10.91	26 390	11.88	33 320	12.72	-
Max rpm	20	18 360	7.46	21 080	7.82	27 350	8.46	34 810	9.00	43 610	9.43	-	-	-	-	-	-
	30	15 930	8.27	18 540	8.77	24 510	9.71	31 580	10.55	39 880	11.31	49 560	11.97	60 730	12.54	-	-
	40	13 130	8.82	15 560	9.47	21 090	10.71	27 620	11.87	35 290	12.95	44 230	13.96	54 570	14.89	66 440	15.73
	50	-	-	-	-	17 260	11.40	23 120	12.88	30 010	14.31	38 080	15.66	47 450	16.95	58 250	18.18
	60	-	-	-	-	-	18 270	13.52	24 250	15.29	31 300	17.01	39 550	18.67	49 150	20.29	-
VTZ215																	
Min rpm	20	8 120	2.86	9 230	2.96	11 840	3.13	15 050	3.26	18 950	3.37	-	-	-	-	-	-
	30	7 050	3.33	8 080	3.48	10 490	3.75	13 430	3.98	16 980	4.16	21 240	4.31	26 290	4.42	-	-
	40	5 820	3.70	6 760	3.93	8 930	4.34	11 550	4.70	14 730	5.00	18 540	5.26	23 070	5.47	28 430	5.64
	50	-	-	-	-	7 240	4.82	9 510	5.35	12 270	5.82	15 590	6.22	19 570	6.58	24 300	6.88
	60	-	-	-	-	-	7 390	5.87	9 680	6.54	12 480	7.14	15 870	7.68	19 930	8.15	-
3600 rpm	20	18 340	6.40	20 730	6.67	26 240	7.17	32 810	7.63	40 570	8.03	-	-	-	-	-	-
	30	15 560	7.08	17 770	7.45	22 830	8.14	28 860	8.79	35 990	9.38	44 350	9.92	54 070	10.39	-	-
	40	12 770	7.55	14 760	8.04	19 310	8.97	24 750	9.85	31 200	10.68	38 800	11.45	47 660	12.16	57 920	12.81
	50	-	-	-	-	15 780	9.62	20 570	10.78	26 290	11.88	33 060	12.93	41 010	13.92	50 280	14.85
	60	-	-	-	-	-	16 390	11.54	21 320	12.96	27 220	14.33	34 210	15.64	42 420	16.89	-
Max rpm	20	24 800	10.30	28 360	10.93	36 500	12.14	46 160	13.25	57 500	14.22	-	-	-	-	-	-
	30	21 240	10.93	24 570	11.71	32 150	13.25	41 100	14.75	51 600	16.17	63 790	17.48	77 850	18.63	-	-
	40	17 530	11.38	20 580	12.27	27 520	14.11	35 690	15.96	45 260	17.81	56 390	19.60	69 250	21.30	84 000	22.87
	50	-	-	-	-	22 680	14.80	29 990	16.98	38 570	19.20	48 570	21.43	60 150	23.64	73 480	25.78
	60	-	-	-	-	-	24 100	17.85	31 600	20.42	40 380	23.06	50 610	25.73	62 450	28.40	-

To: Evaporating temperature in °C
Superheat = 10 K

Tc: Condensing temperature in °C
Subcooling = 0 K

Qo: Cooling capacity in W

Pe: Power input in kW

Min rpm: Minimum rotation speed

3600 rpm: Rotation speed 3600 rpm

Max rpm: Maximum rotation speed

Performance data

R134a

	To	-15		-10		-5		0		5		10		15	
	Tc	Qo	Pe	Qo	Pe	Qo	Pe	Qo	Pe	Qo	Pe	Qo	Pe	Qo	Pe
VTZ038															
Min rpm	35	840	0.51	1 110	0.58	1 460	0.64	1 900	0.69	2 430	0.72	3 090	0.74	3 880	0.74
	45	660	0.52	920	0.61	1 230	0.68	1 620	0.75	2 100	0.81	2 690	0.85	3 420	0.88
	55	500	0.52	720	0.62	990	0.71	1 330	0.79	1 750	0.87	2 280	0.94	2 920	0.99
	65	-	-	-	-	-	-	1 040	0.84	1 400	0.93	1 850	1.01	2 420	1.09
	70	-	-	-	-	-	-	-	-	-	-	1 650	1.06	2 170	1.14
3600 rpm	35	1 550	0.93	2 060	1.05	2 710	1.15	3 510	1.24	4 510	1.30	5 730	1.34	7 200	1.36
	45	1 230	0.95	1 690	1.10	2 270	1.24	2 990	1.36	3 890	1.46	4 990	1.54	6 330	1.60
	55	920	0.94	1 320	1.12	1 820	1.29	2 450	1.44	3 240	1.57	4 210	1.69	5 410	1.79
	65	-	-	-	-	-	-	1 920	1.52	2 590	1.69	3 430	1.84	4 470	1.97
	70	-	-	-	-	-	-	-	-	-	-	3 040	1.93	4 000	2.08
Max rpm	35	2 340	1.37	3 130	1.54	4 110	1.69	5 340	1.81	6 850	1.90	8 700	1.97	10 930	2.00
	45	1 860	1.41	2 560	1.63	3 440	1.83	4 530	2.00	5 890	2.15	7 560	2.27	9 580	2.35
	55	1 410	1.39	2 010	1.65	2 770	1.89	3 720	2.12	4 910	2.32	6 380	2.49	8 190	2.64
	65	-	-	-	-	-	-	2 920	2.23	3 930	2.48	5 200	2.71	6 780	2.92
	70	-	-	-	-	-	-	-	-	-	-	4 630	2.85	6 080	3.08
VTZ054															
Min rpm	35	1 280	0.71	1 720	0.79	2 250	0.86	2 880	0.93	3 620	1.00	4 490	1.06	5 490	1.11
	45	1 050	0.74	1 440	0.84	1 910	0.93	2 470	1.03	3 140	1.12	3 910	1.20	4 800	1.28
	55	820	0.77	1 160	0.88	1 580	0.99	2 070	1.11	2 650	1.22	3 330	1.34	4 110	1.45
	65	-	-	-	-	-	-	1 670	1.18	2 170	1.31	2 750	1.45	3 430	1.59
	70	-	-	-	-	-	-	-	-	-	-	2 460	1.51	3 090	1.66
3600 rpm	35	2 370	1.28	3 180	1.42	4 160	1.56	5 320	1.69	6 700	1.81	8 310	1.91	10 160	2.00
	45	1 940	1.35	2 660	1.52	3 540	1.69	4 570	1.86	5 800	2.02	7 230	2.18	8 890	2.32
	55	1 510	1.39	2 150	1.59	2 920	1.80	3 830	2.00	4 900	2.21	6 160	2.42	7 620	2.62
	65	-	-	-	-	-	-	3 080	2.12	4 000	2.37	5 090	2.63	6 350	2.89
	70	-	-	-	-	-	-	-	-	-	-	4 550	2.73	5 720	3.01
Max rpm	35	3 590	1.88	4 820	2.09	6 300	2.29	8 070	2.48	10 160	2.66	12 600	2.81	15 410	2.94
	45	2 940	1.98	4 040	2.23	5 360	2.49	6 940	2.74	8 790	2.98	10 970	3.21	13 480	3.42
	55	2 290	2.05	3 270	2.34	4 430	2.64	5 800	2.95	7 430	3.25	9 340	3.55	11 560	3.85
	65	-	-	-	-	-	-	4 680	3.13	6 070	3.49	7 720	3.86	9 640	4.23
	70	-	-	-	-	-	-	-	-	-	-	6 910	4.01	8 680	4.41
VTZ086															
Min rpm	35	1 660	0.96	2 280	1.08	3 030	1.17	3 930	1.24	4 990	1.30	6 240	1.33	7 690	1.36
	45	1 330	0.99	1 880	1.15	2 550	1.27	3 350	1.38	4 290	1.48	5 410	1.56	6 700	1.63
	55	1 000	0.99	1 480	1.18	2 060	1.34	2 750	1.48	3 570	1.61	4 550	1.73	5 680	1.83
	65	-	-	-	-	-	-	2 150	1.57	2 850	1.73	3 670	1.88	4 650	2.02
	70	-	-	-	-	-	-	-	-	-	-	3 240	1.95	4 130	2.11
3600 rpm	35	3 580	2.05	4 910	2.28	6 530	2.46	8 480	2.61	10 790	2.74	13 510	2.85	16 670	2.96
	45	2 870	2.11	4 060	2.43	5 500	2.69	7 220	2.91	9 270	3.10	11 680	3.27	14 480	3.44
	55	2 150	2.08	3 190	2.48	4 440	2.83	5 940	3.13	7 720	3.40	9 820	3.64	12 270	3.87
	65	-	-	-	-	-	-	4 650	3.28	6 160	3.64	7 940	3.96	10 040	4.27
	70	-	-	-	-	-	-	-	-	-	-	7 010	4.11	8 920	4.46
Max rpm	35	5 430	2.99	7 440	3.38	9 900	3.67	12 860	3.88	16 380	4.03	20 500	4.12	25 300	4.17
	45	4 370	3.06	6 170	3.56	8 350	3.98	10 970	4.32	14 080	4.61	17 740	4.84	22 000	5.04
	55	3 270	3.06	4 850	3.65	6 750	4.16	9 020	4.61	11 730	5.00	14 910	5.35	18 640	5.67
	65	-	-	-	-	-	-	7 050	4.90	9 340	5.37	12 050	5.80	15 230	6.22
	70	-	-	-	-	-	-	-	-	-	-	10 610	6.06	13 520	6.51
VTZ121															
Min rpm	35	2 620	1.33	3 360	1.46	4 250	1.59	5 330	1.71	6 610	1.83	8 130	1.93	9 900	2.02
	45	2 240	1.44	2 900	1.61	3 710	1.78	4 690	1.93	5 860	2.08	7 240	2.23	8 860	2.36
	55	1 830	1.53	2 400	1.73	3 100	1.93	3 960	2.13	4 990	2.32	6 230	2.51	7 680	2.69
	65	-	-	-	-	-	-	3 190	2.29	4 070	2.53	5 130	2.76	6 400	2.99
	70	-	-	-	-	-	-	-	-	-	-	4 560	2.87	5 730	3.12
3600 rpm	35	5 500	2.79	7 050	3.07	8 930	3.34	11 190	3.59	13 890	3.83	17 070	4.05	20 790	4.24
	45	4 690	3.03	6 090	3.39	7 790	3.73	9 840	4.06	12 300	4.38	15 200	4.68	18 610	4.95
	55	3 840	3.20	5 040	3.63	6 520	4.06	8 310	4.47	10 480	4.88	13 070	5.27	16 130	5.64
	65	-	-	-	-	-	-	6 700	4.80	8 540	5.30	10 770	5.79	13 430	6.27
	70	-	-	-	-	-	-	-	-	-	-	9 570	6.02	12 030	6.55
Max rpm	35	7 850	3.88	10 050	4.27	12 730	4.65	15 960	5.01	19 810	5.33	24 350	5.61	29 640	5.84
	45	6 690	4.21	8 680	4.69	11 100	5.17	14 030	5.64	17 530	6.09	21 680	6.52	26 540	6.90
	55	5 470	4.48	7 180	5.05	9 290	5.62	11 850	6.20	14 950	6.77	18 640	7.33	23 000	7.87
	65	-	-	-	-	-	-	9 550	6.67	12 170	7.36	15 350	8.05	19 160	8.73
	70	-	-	-	-	-	-	-	-	-	-	13 650	8.37	17 150	9.12

Performance data
R134a

	To	-15		-10		-5		0		5		10		15	
	Tc	Qo	Pe	Qo	Pe	Qo	Pe	Qo	Pe	Qo	Pe	Qo	Pe	Qo	Pe
VTZ171															
Min rpm	35	3 220	2.04	4 460	2.22	5 980	2.36	7 800	2.48	9 970	2.57	12 520	2.66	15 470	2.76
	45	2 500	2.12	3 600	2.39	4 940	2.61	6 550	2.79	8 470	2.94	10 730	3.07	13 370	3.19
	55	1 790	2.07	2 750	2.46	3 900	2.79	5 300	3.07	6 960	3.30	8 940	3.50	11 250	3.67
	65	-	-	-	-	-	-	4 070	3.26	5 470	3.60	7 150	3.90	9 130	4.16
	70	-	-	-	-	-	-	-	-	-	-	6 270	4.07	8 080	4.39
3600 rpm	35	7 260	4.16	9 920	4.61	13 140	5.00	16 970	5.34	21 490	5.64	26 760	5.90	32 850	6.13
	45	5 710	4.26	8 120	4.87	11 000	5.40	14 440	5.88	18 490	6.29	23 220	6.66	28 700	6.99
	55	4 090	4.12	6 230	4.93	8 770	5.65	11 780	6.29	15 340	6.87	19 510	7.38	24 360	7.85
	65	-	-	-	-	-	-	9 060	6.51	12 110	7.28	15 700	7.98	19 900	8.62
	70	-	-	-	-	-	-	-	-	-	-	13 780	8.21	17 640	8.95
Max rpm	35	11 120	6.17	15 050	7.09	19 760	7.89	25 350	8.55	31 900	9.05	39 520	9.39	48 310	9.54
	45	8 810	6.21	12 420	7.31	16 730	8.35	21 830	9.32	27 830	10.20	34 820	10.99	42 900	11.66
	55	6 440	6.22	9 650	7.36	13 470	8.51	18 010	9.65	23 370	10.78	29 640	11.88	36 920	12.94
	65	-	-	-	-	-	-	14 050	10.01	18 690	11.25	24 160	12.53	30 570	13.83
	70	-	-	-	-	-	-	-	-	-	-	21 370	12.90	27 310	14.28
VTZ215															
Min rpm	35	4 680	2.68	6 190	2.94	8 010	3.17	10 160	3.38	12 690	3.60	15 630	3.84	19 030	4.11
	45	3 880	2.84	5 260	3.19	6 910	3.49	8 860	3.75	11 160	4.01	13 830	4.26	16 930	4.52
	55	3 030	2.86	4 260	3.34	5 720	3.75	7 460	4.11	9 500	4.44	11 890	4.75	14 670	5.05
	65	-	-	-	-	-	-	6 000	4.34	7 770	4.79	9 850	5.20	12 290	5.58
	70	-	-	-	-	-	-	-	-	-	-	8 810	5.37	11 060	5.81
3600 rpm	35	10 080	5.68	13 370	6.24	17 320	6.74	21 990	7.22	27 450	7.69	33 780	8.19	41 030	8.73
	45	8 380	6.01	11 390	6.75	14 970	7.40	19 180	7.99	24 100	8.53	29 800	9.06	36 340	9.60
	55	6 490	6.04	9 220	7.04	12 430	7.91	16 200	8.69	20 580	9.38	25 650	10.02	31 470	10.64
	65	-	-	-	-	-	-	12 990	9.17	16 830	10.10	21 270	10.93	26 380	11.70
	70	-	-	-	-	-	-	-	-	-	-	18 990	11.31	23 750	12.19
Max rpm	35	15 310	8.39	20 250	9.17	26 180	9.90	33 210	10.60	41 480	11.30	51 110	12.05	62 220	12.86
	45	12 700	8.86	17 230	9.89	22 630	10.83	29 030	11.70	36 560	12.55	45 340	13.39	55 480	14.26
	55	9 920	8.97	13 960	10.34	18 770	11.57	24 460	12.70	31 170	13.76	39 010	14.78	48 120	15.80
	65	-	-	-	-	-	-	19 640	13.47	25 450	14.83	32 290	16.11	40 280	17.34
	70	-	-	-	-	-	-	-	-	-	-	28 830	16.70	36 230	18.08

To: Evaporating temperature in °C
Superheat = 10 K

Tc: Condensing temperature in °C
Subcooling = 0 K

Qo: Cooling capacity in W

Pe: Power input in kW

Min rpm: Minimum rotation speed

3600 rpm: Rotation speed 3600 rpm

Max rpm: Maximum rotation speed

VTZ038 / VTZ054

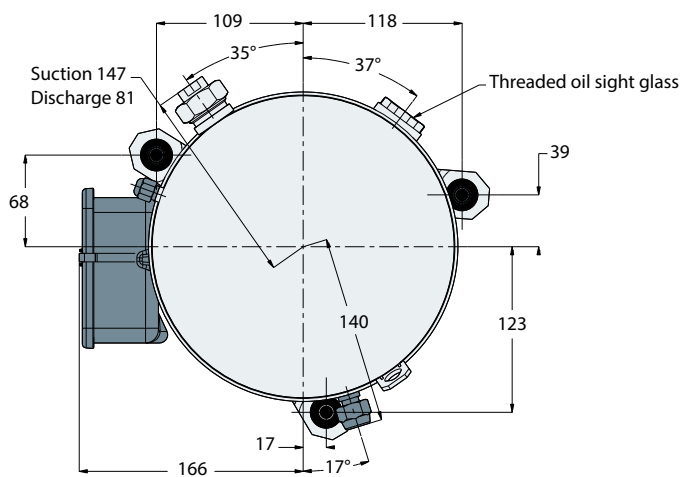
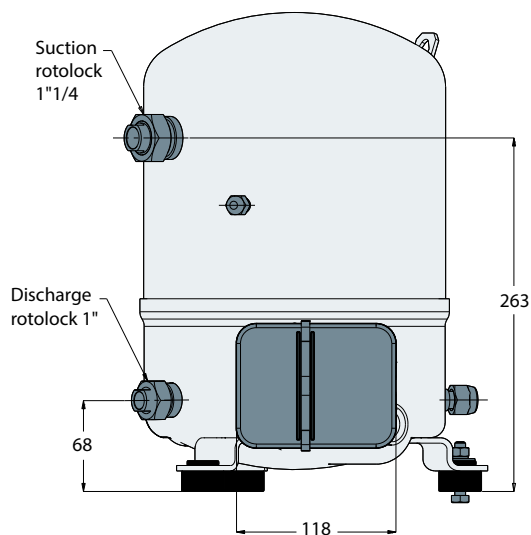
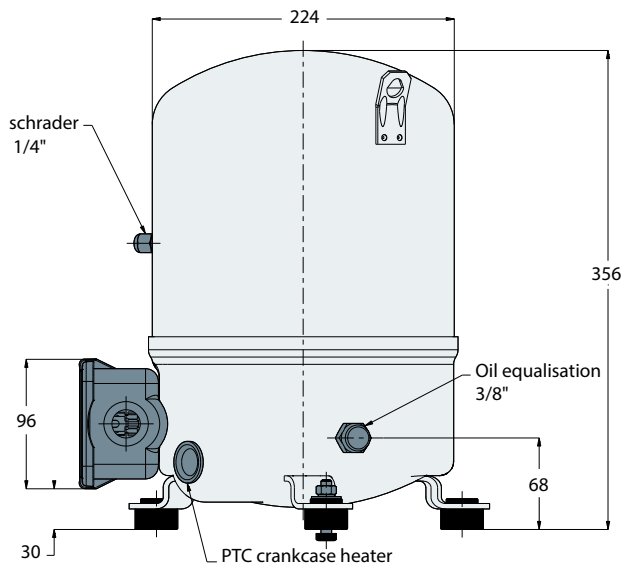

Quiet bloc

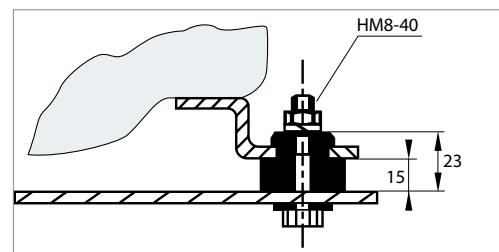

Grommet compression not included around 1 mm

Terminal box

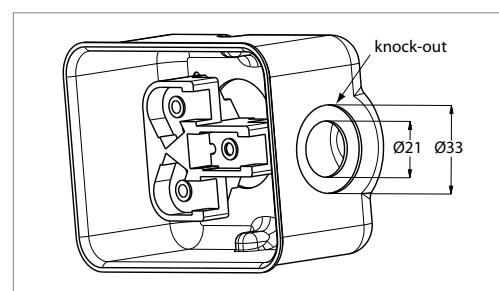

VTZ086 / VTZ121

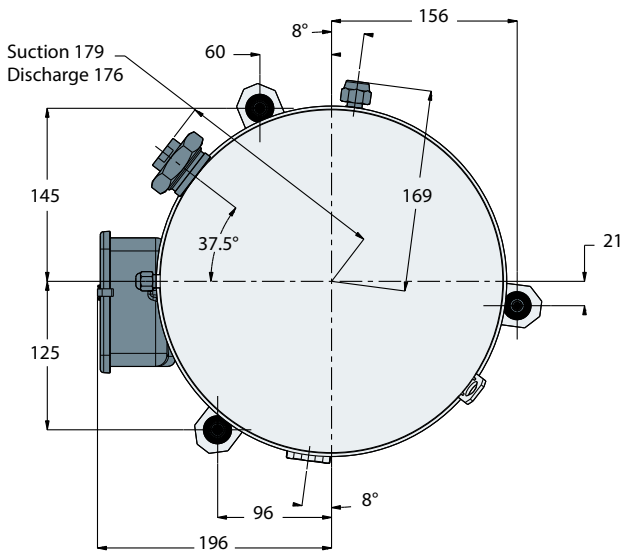
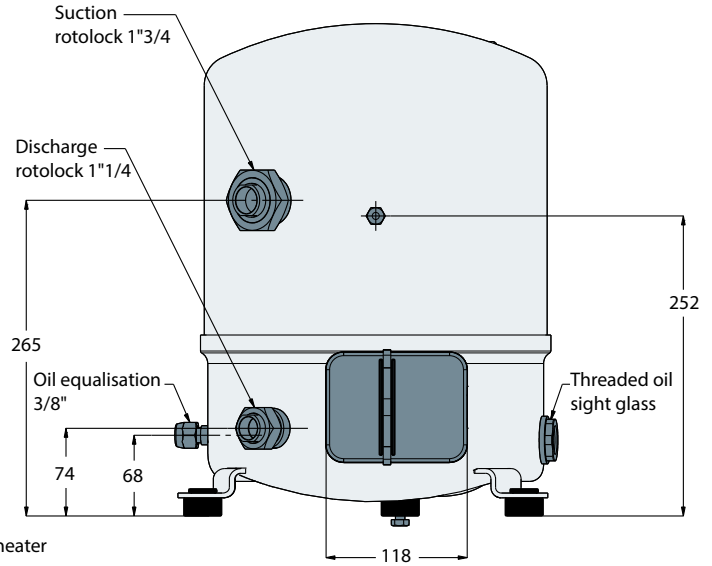
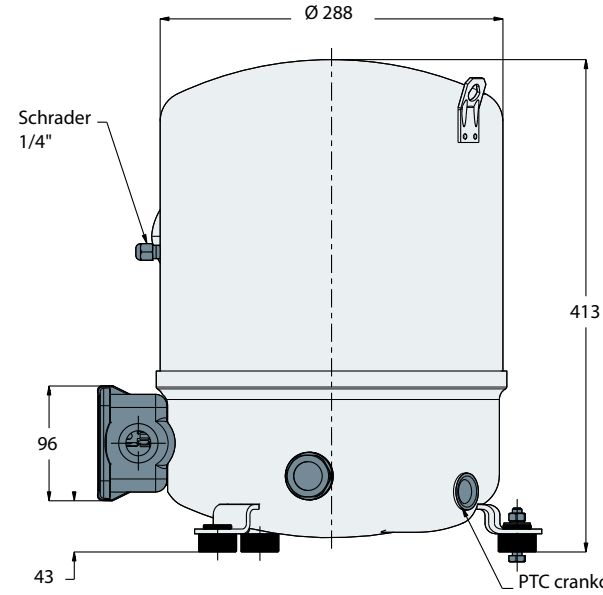

Silent bloc

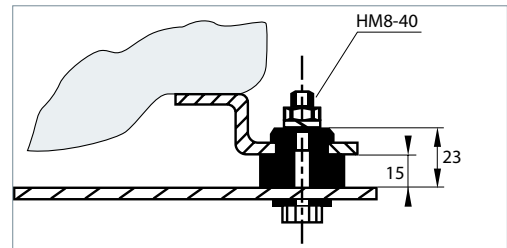

Grommet compression not included around 1 mm

Terminal box

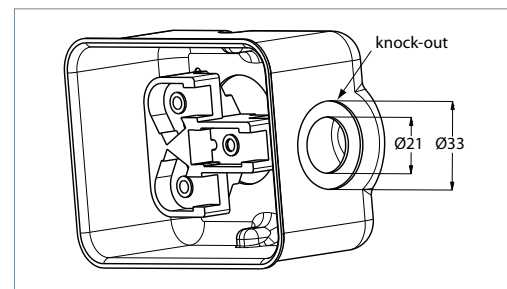

VTZ171 / VTZ215

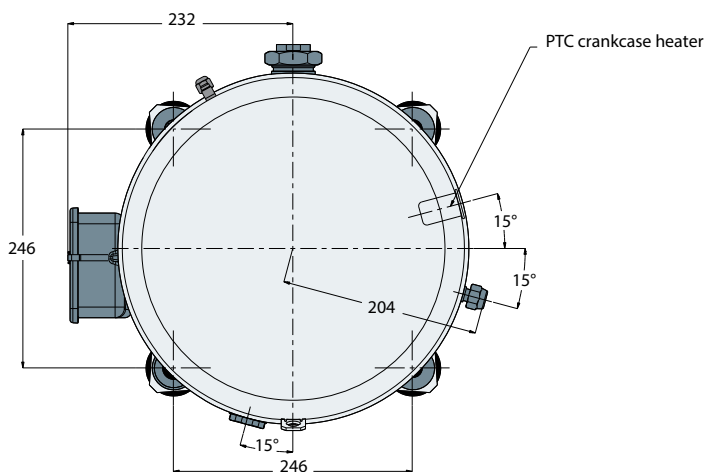
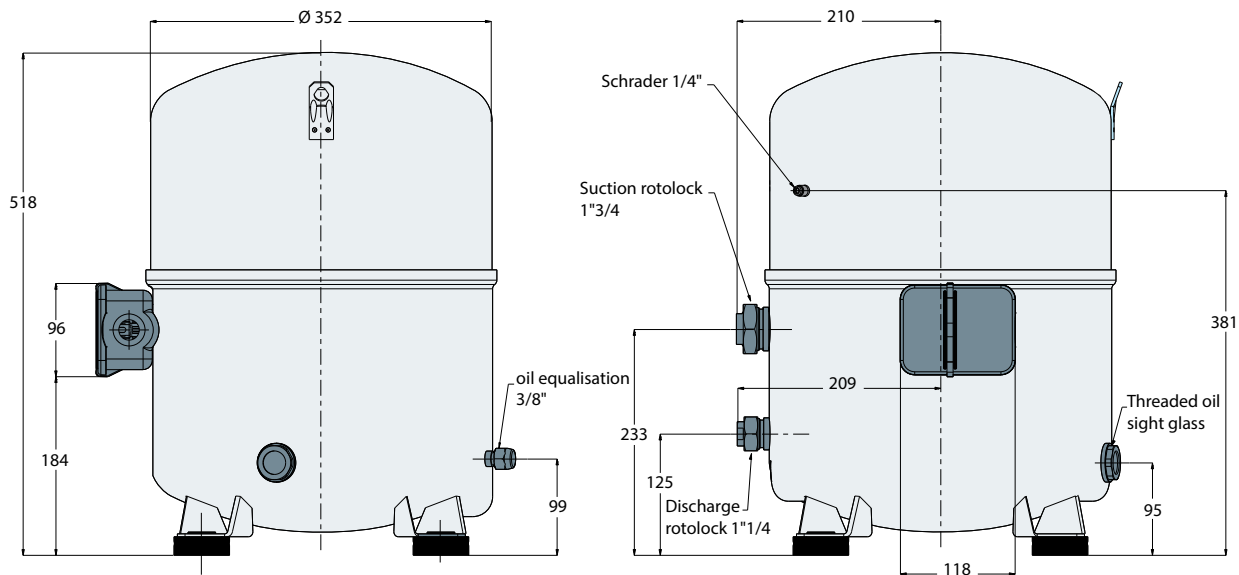

Quiet bloc

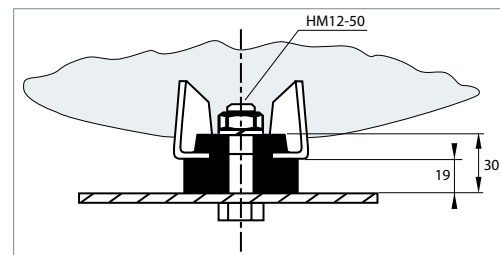

Grommet compression not included around 1 mm

Terminal box

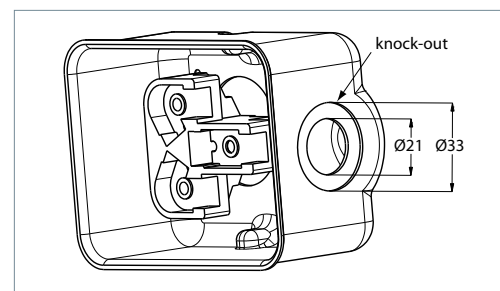

Application Guidelines

Dimensions

Sight glass

VTZ compressors come equipped with a threaded oil sight glass with 1"1/8 – 18 UNEF connection. It can be used for visual check of oil

amount and conditions, or it may be replaced by an oil management device.

Schrader

The oil fill connection and gauge port is a 1/4" male flare connector incorporating a schrader valve.

Suction & discharge connections

VTZ compressors are all delivered with suction and discharge rotolock connections only.

	Rotolock connections size		Pipe sizing		Rotolock valve	
	Suction	Discharge	Suction	Discharge	Suction	Discharge
VTZ038-054	1"1/4	1"	5/8"	1/2"	V09	V06
VTZ086-121	1"3/4	1"1/4	7/8"	3/4"	V07	V04
VTZ171-215	1"3/4	1"1/4	1"1/8	3/4"	V02	V04

Frequency converter dimensions

Frequency converter dimensions depend on supply voltage, IP rating and power. The below table gives an overview of the overall dimensions and different enclosures. Details for each enclosure are on the following pages.

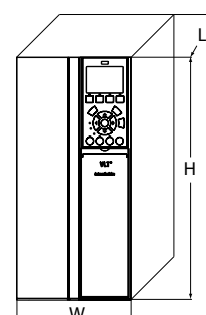

Drive supply voltage	Drive power (kW)	Compressor voltage code	Compressor model	IP20			IP21			IP55		
				Drive enclosure	Overall dimension (hxwx d) mm	Weight (kg)	Drive enclosure	Overall dimension (hxwx d) mm	Weight (kg)	Drive enclosure	Overall dimension (hxwx d) mm	Weight (kg)
T2 : 200-240/3/50-60	3.7	J	VTZ038	A3	268x130x205	6.6	-	-	-	B1	480x242x260	23
	5.5		VTZ054	-	-	-	B1	494x242x260	23	B1	480x242x260	23
	7.5		VTZ086	-	-	-	B1	494x242x260	23	B1	480x242x260	23
	11		VTZ121	-	-	-	B2	664x242x260	27	B2	664x242x260	27
T4 : 380-480/3/50-60	4	G	VTZ038	A2	268x90x205	4.9	-	-	-	A5	420x242x200	13.5
	5.5		VTZ054	A3	268x130x205	6.6	-	-	-	A5	420x242x200	13.5
	7.5		VTZ086	A3	268x130x205	6.6	-	-	-	A5	420x242x200	13.5
	11		VTZ121	B3	399x165x248	12	B1	494x242x260	23	B1	480x242x260	23
	15		VTZ171	B3	399x165x248	12	B1	494x242x260	23	B1	480x242x260	23
	18.5		VTZ215	-	-	-	B2	664x242x260	27	B2	650x242x260	27

Frequency converters Enclosure A2 - IP20

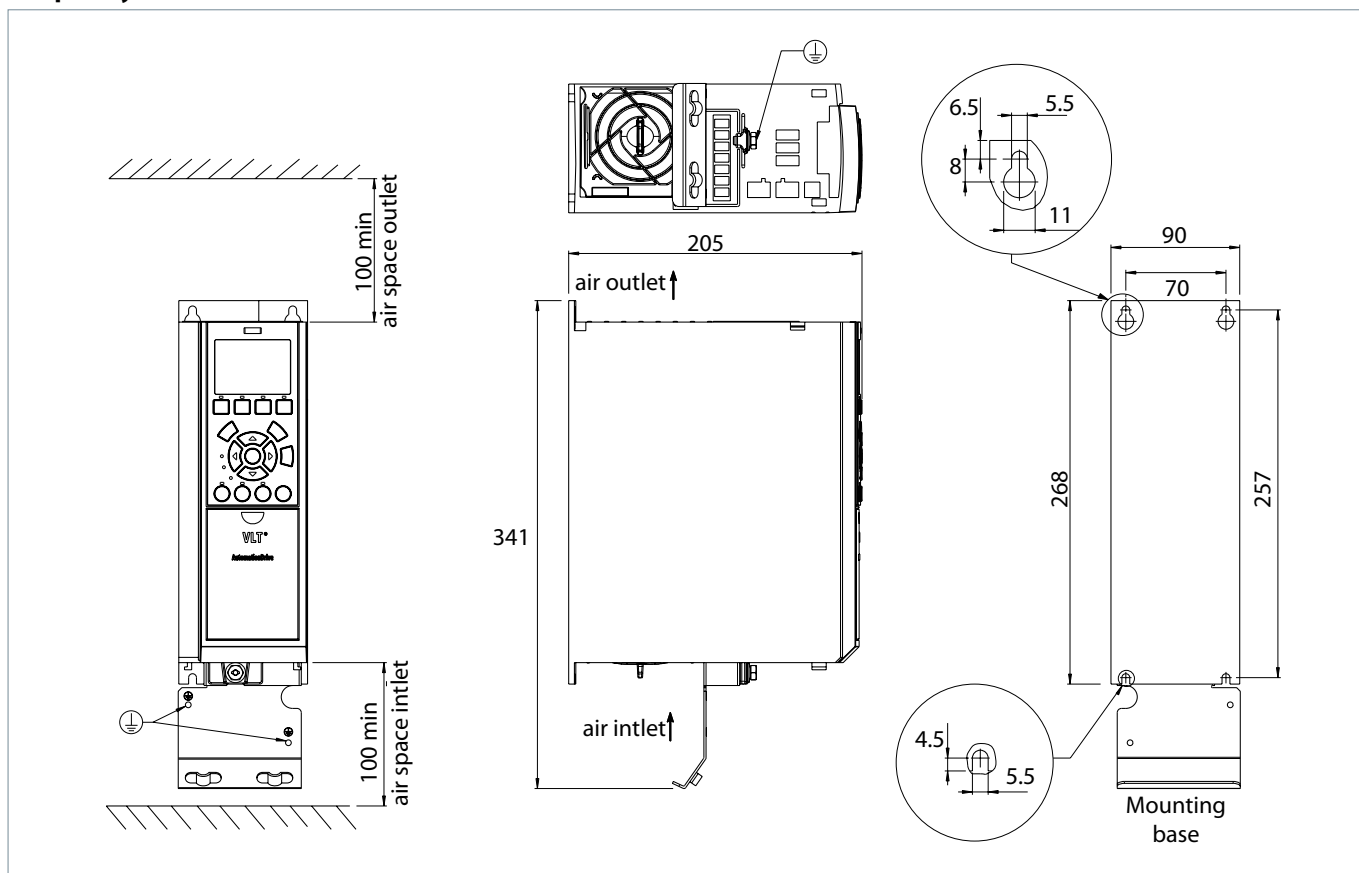

Frequency converters Enclosure A3 - IP20

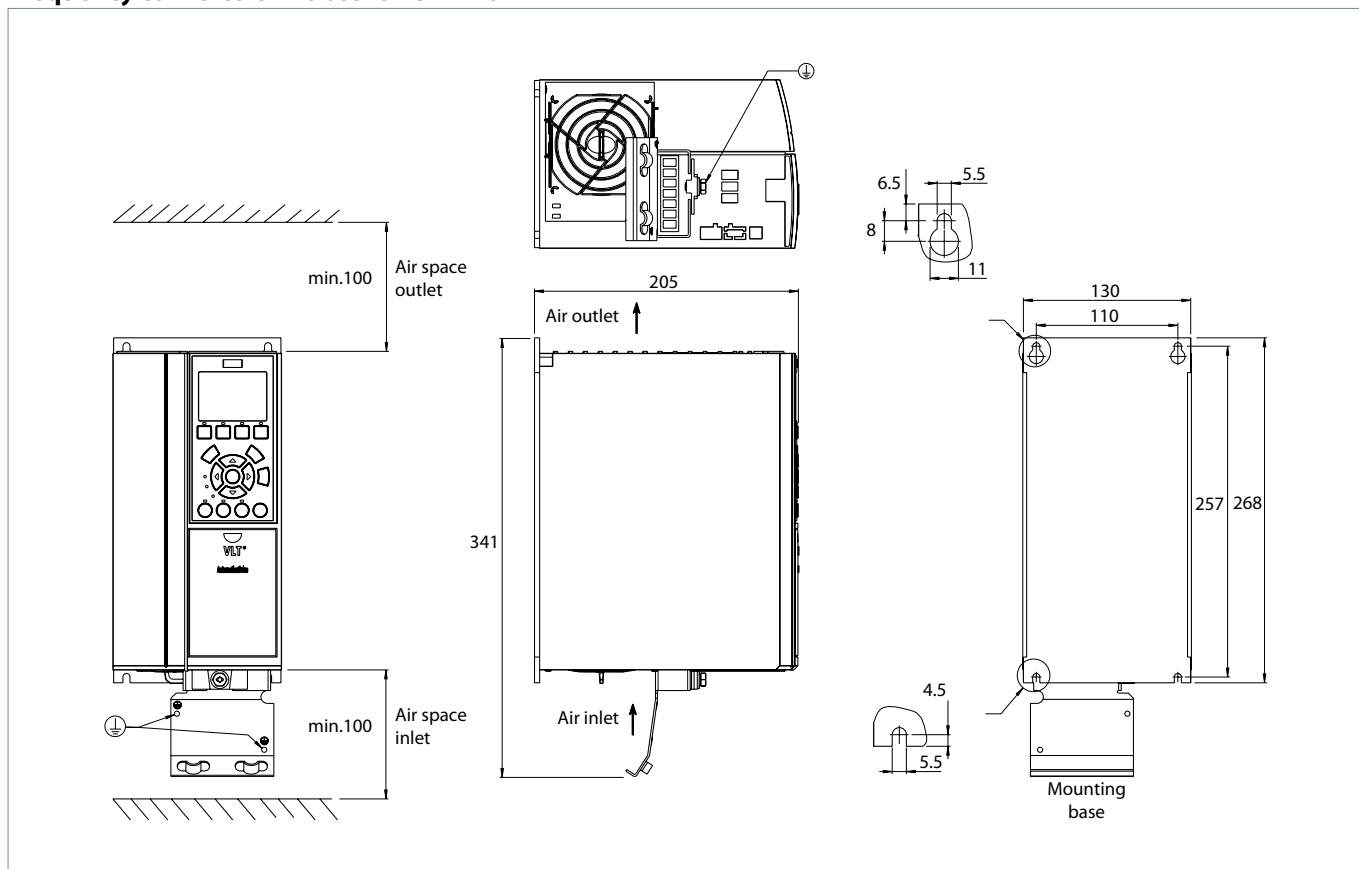

Frequency converters Enclosure B3 - IP20

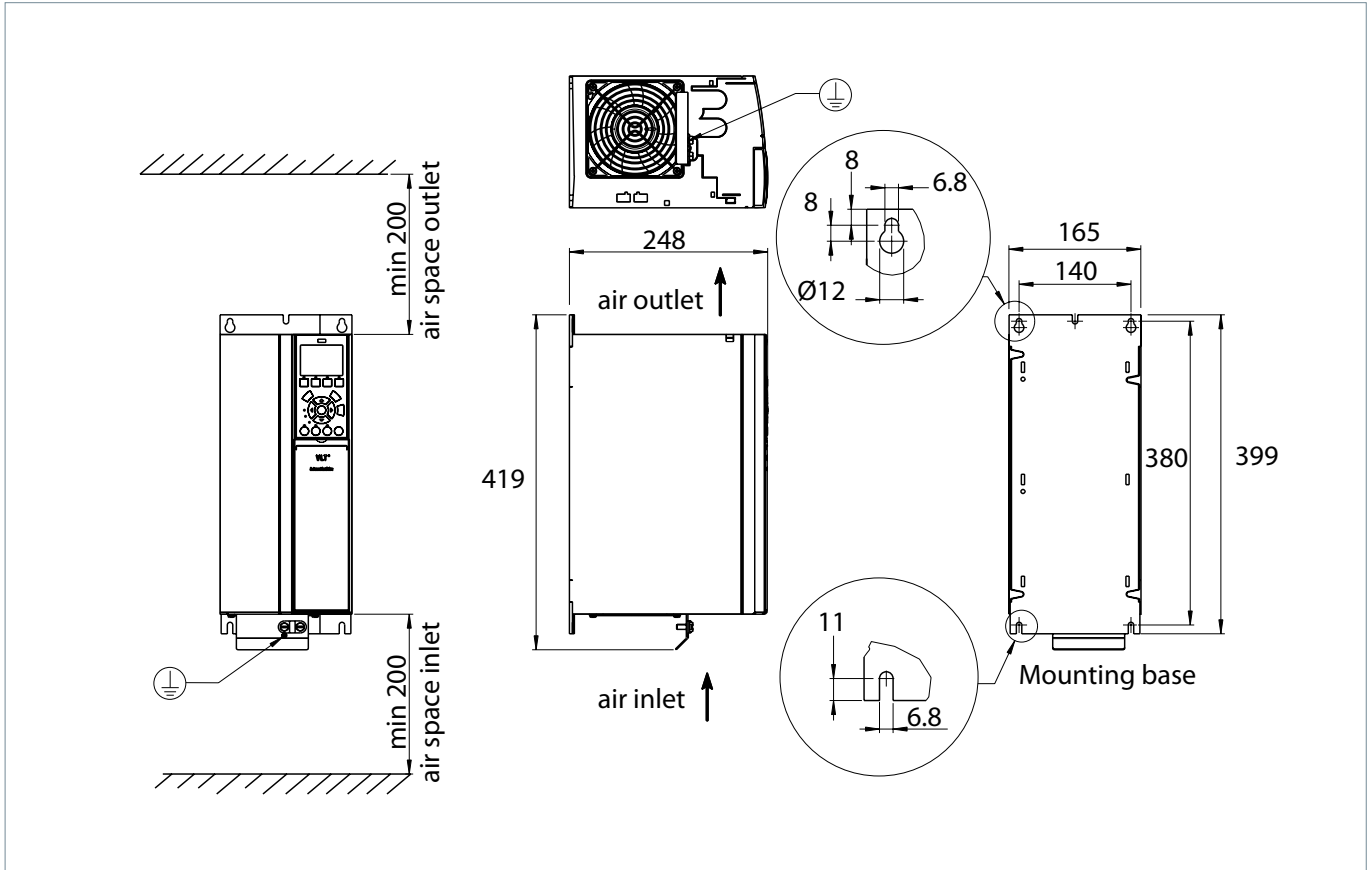

Frequency converters Enclosure B1 - IP21

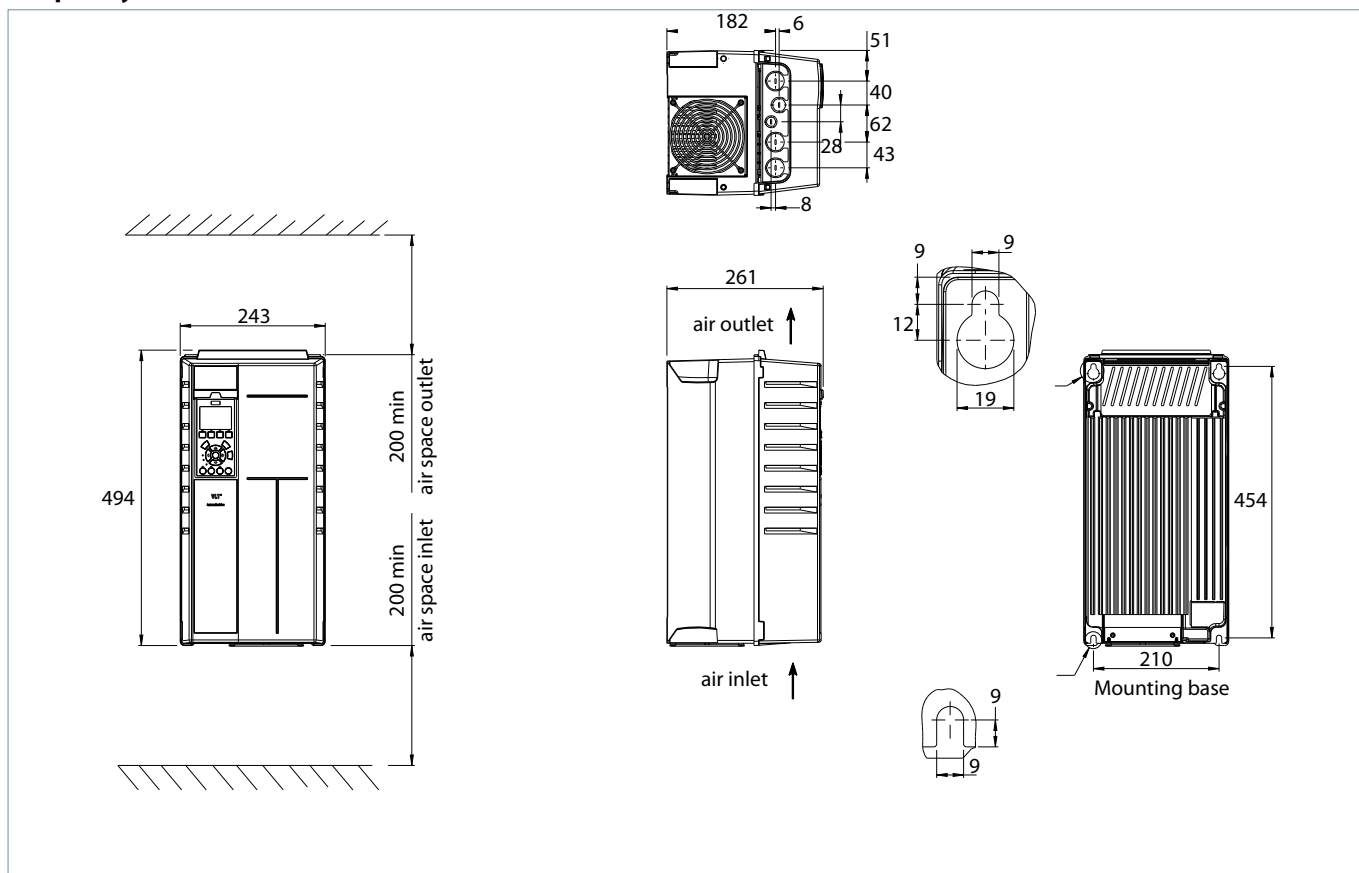

Frequency converters Enclosure B2 - IP21

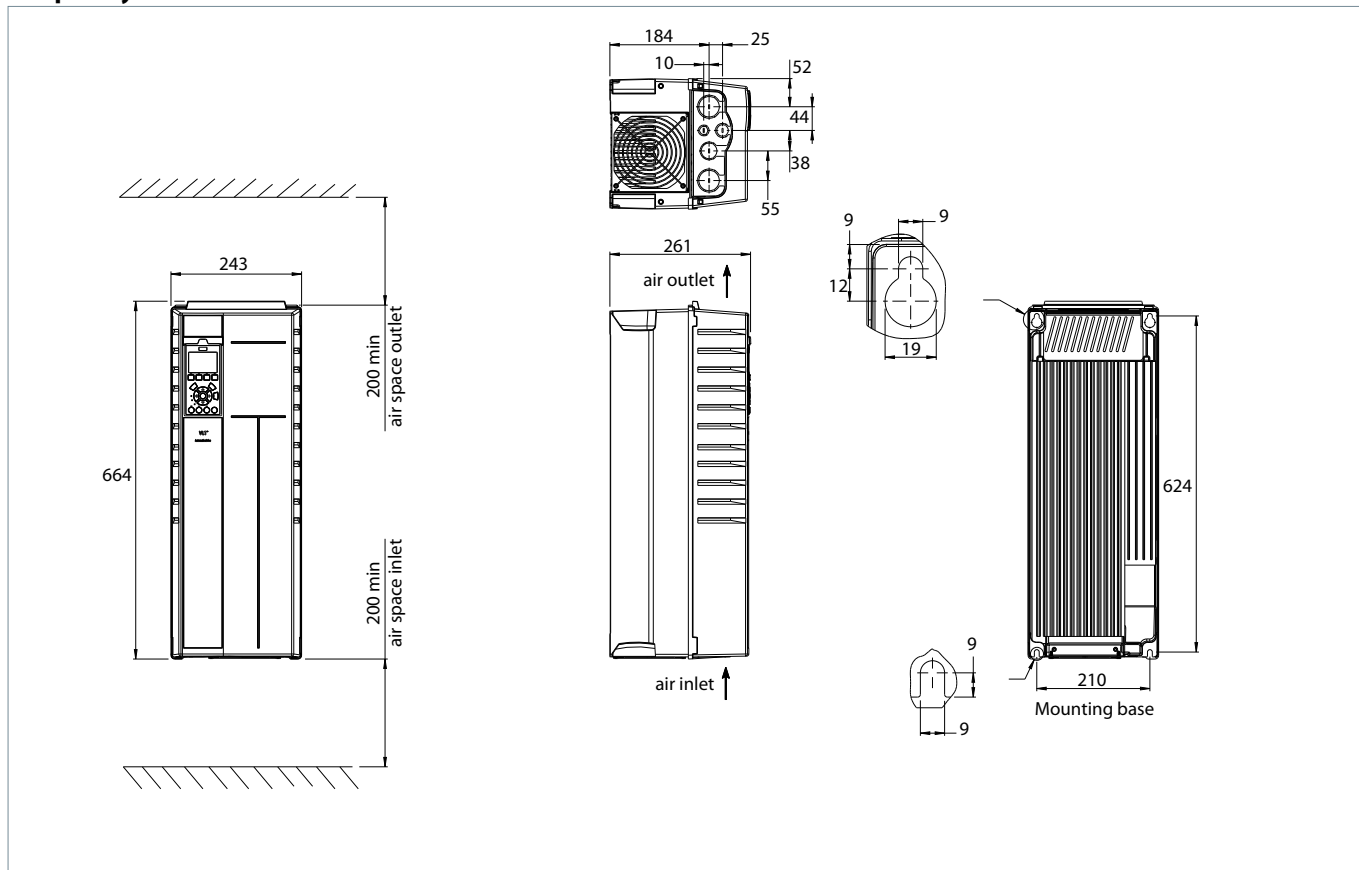

Frequency converters Enclosure A5 - IP55

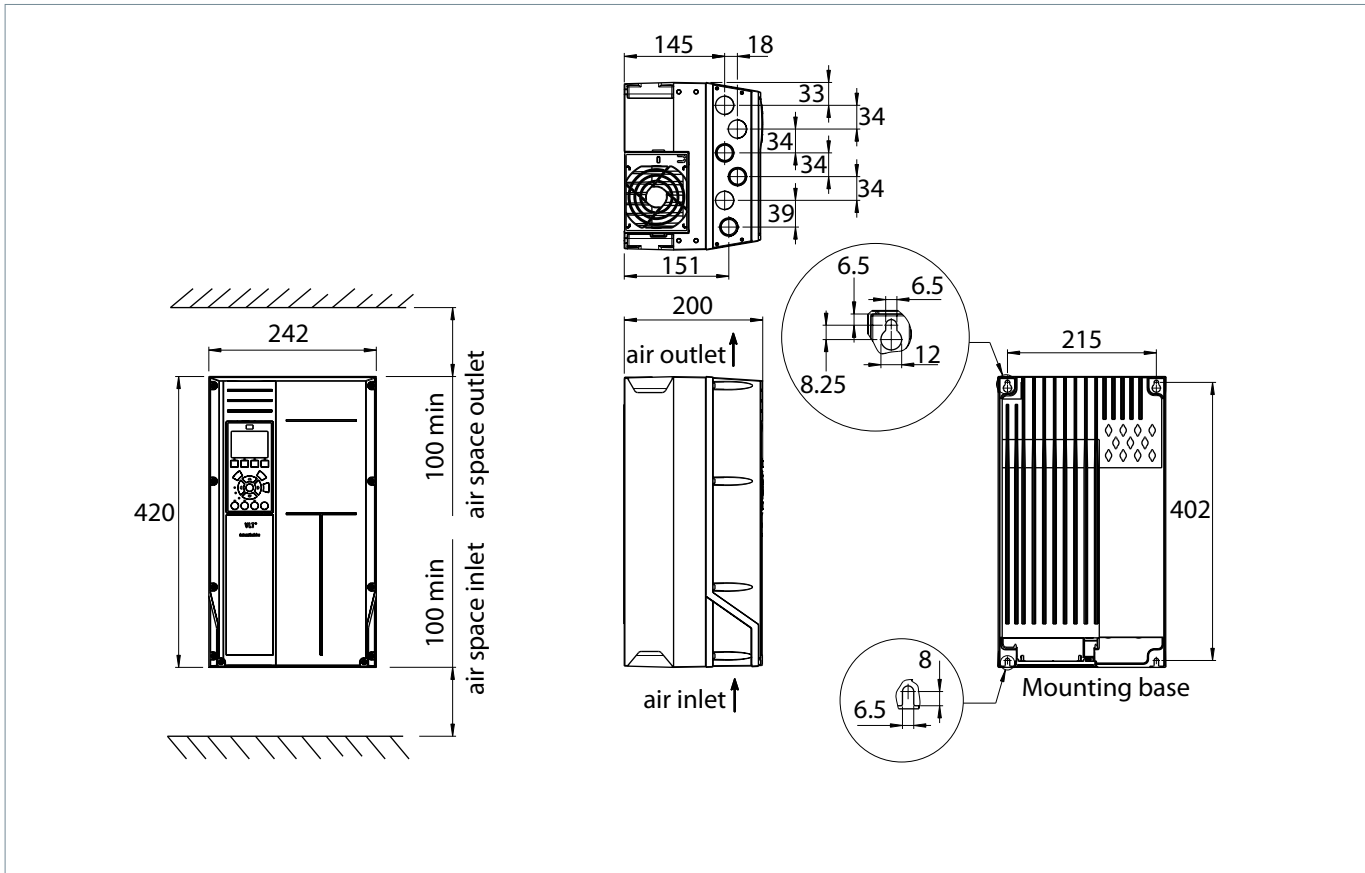

Frequency converters Enclosure B1 - IP55

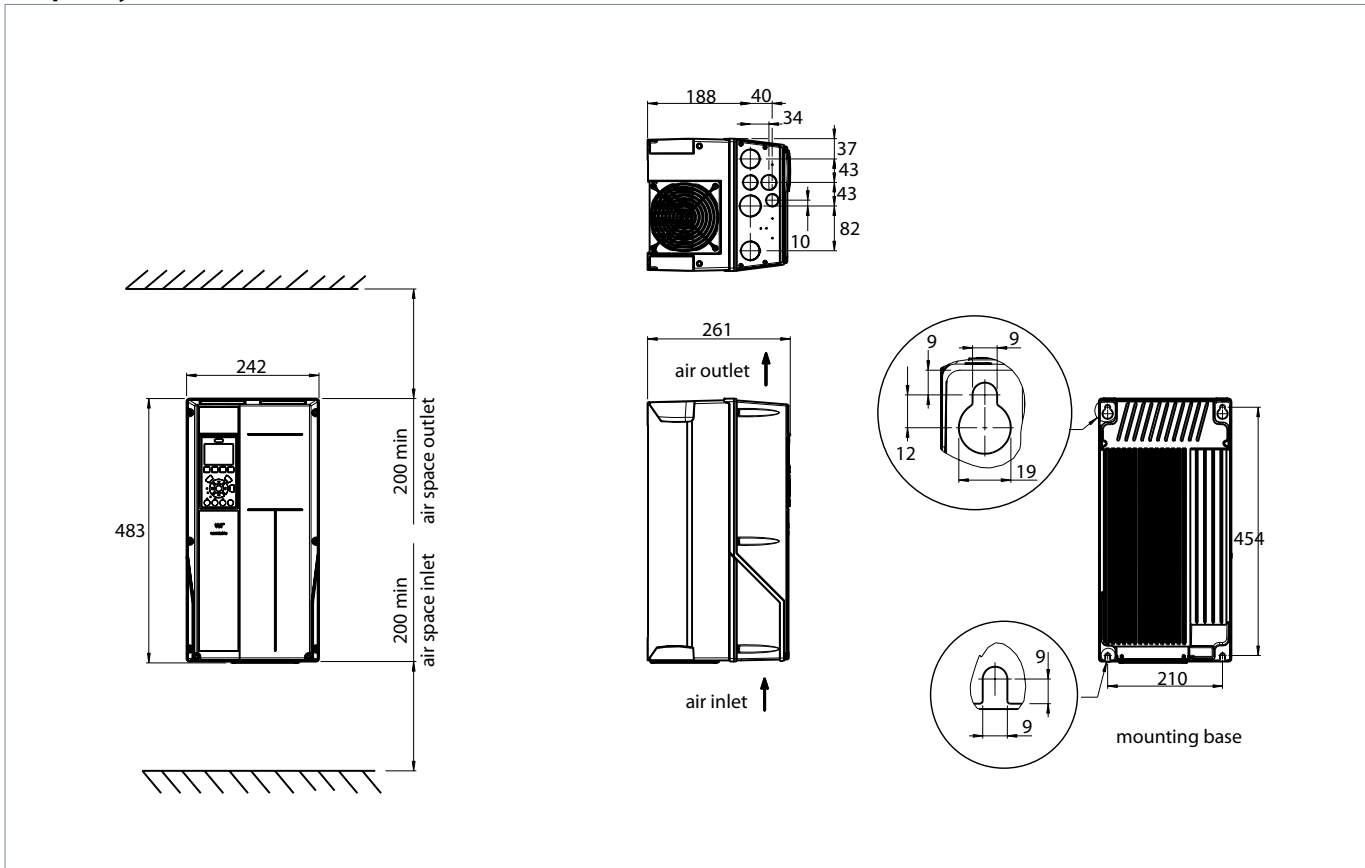

Frequency converters Enclosure B2 - IP55

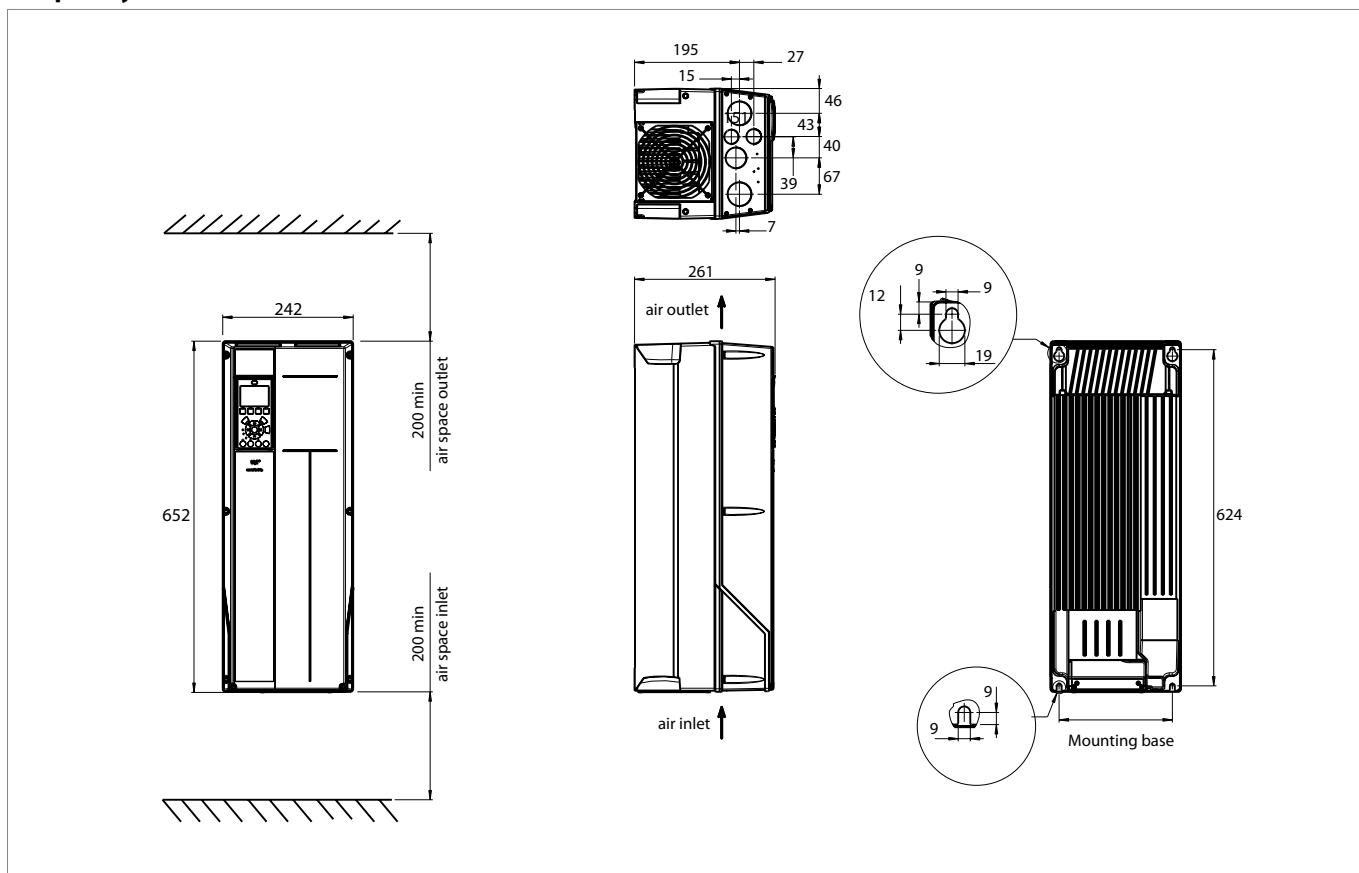

This chapter summarizes the most essential points for VTZ and CD302 electrical installation.

An exhaustive description can be found in literature 85.10.233 (instructions for installation).

Compressor electrical specifications

	Compressor	Nominal motor power (in kW)	RW (Ohm)	RT (Ohm)	RLA (A)	MMT (A)	LRA (A)
200-240 V	VTZ038-J	3.59	0.31	0.65	13.5	17	69
	VTZ054-J	5	0.215	0.44	20	25	93
	VTZ086-J	7.8	0.158	0.317	32.5	40.6	88
	VTZ121-J	12.5	0.095	0.156	50	64.4	160
380-480 Volt	VTZ038-G	3.59	1.684	3.37	7.35	9.2	30.5
	VTZ054-G	4.95	1.039	2.08	12	15	47
	VTZ086-G	7.8	0.685	1.37	16	20	74
	VTZ121-G	11.66	0.294	0.59	23.2	29	139
	VTZ171-G	16	0.337	0.67	30.5	38.1	130
	VTZ215-G	21.3	0.236	0.47	40.8	51	197

RW: Winding resistance per winding (in CD302 parameter list)
 RT: Winding resistance as measured at motor terminals
 RLA: Rated load current with R404A @ +5/+60°C
 MMT: Maximum must trip current
 LRA: Locked rotor current

Note that parameter 1-30 in the frequency converter settings reflects the winding resistance per winding. This is not the same value as measured at the motor terminals.

LRA (Locked Rotor Amp)

Locked Rotor Amp value is the higher average current as measured on a mechanically blocked compressor tested under nominal voltage. As required by UL regulation, this value is printed

on the nameplate. This current value can not be achieved in the case of VTZ compressors, because the frequency converter will cut-out the mains before, according to MMT value.

RLA (Rated Load Amp)

Rated Load Amp value is the current value at maximum load, in the operating envelope, and at maximum speed.

MMT (Maximum Must Trip current)

The Maximum Must Trip current is defined for compressors not equipped with their own motor protection. This MMT value is the maximum at which the compressor can be operated in transient conditions and out of the operating envelope. The tripping current of external over-

current protection must never exceed the MMT value.

For VTZ compressors, according to UL requirements, MMT value is 125% of RLA. This value is printed on the compressor nameplate.

Wiring & EMC protection

The motor compressor power supply (from the CD302 frequency converter to the VTZ compressor) must be done with a braided screened/armored cable. This cable needs to have its screen/armor conduit connected to earth on both ends. Avoid terminating this cable connection with twisting ends (pigtailes) because that would result in an antenna phenomena and decreases the effectiveness of the cable.

and the metal chassis of the converter. Use star-washers and galvanically conductive installation plates to secure good electrical connections. Refer to instructions 85.10.233 for tightening torques and screw sizes.

Control cables to the CD302 frequency converter must use the same installation principles as the power supply cable.

Below table lists recommended wiring sizes for the motor compressor power supply cables. These wiring sizes are valid for a cable length up to 20 m.

The motor compressor cable must be installed in a conduit separate from the control and mains cables.

	Compressor	Recommended wiring size	
		mm ²	AWG
200-240 V	VTZ038-J	4	12
	VTZ054-J	4	12
	VTZ086-J	6	10
	VTZ121-J	10	8
380-480 Volt	VTZ038-G	2.5	14
	VTZ054-G	2.5	14
	VTZ086-G	4	12
	VTZ121-G	6	10
	VTZ171-G	10	8
	VTZ215-G	10	8

Physical installation of the frequency converter on the mounting plate must ensure good electrical contact between the mounting plate

EMC correct installation of an IP20 frequency converter CD302

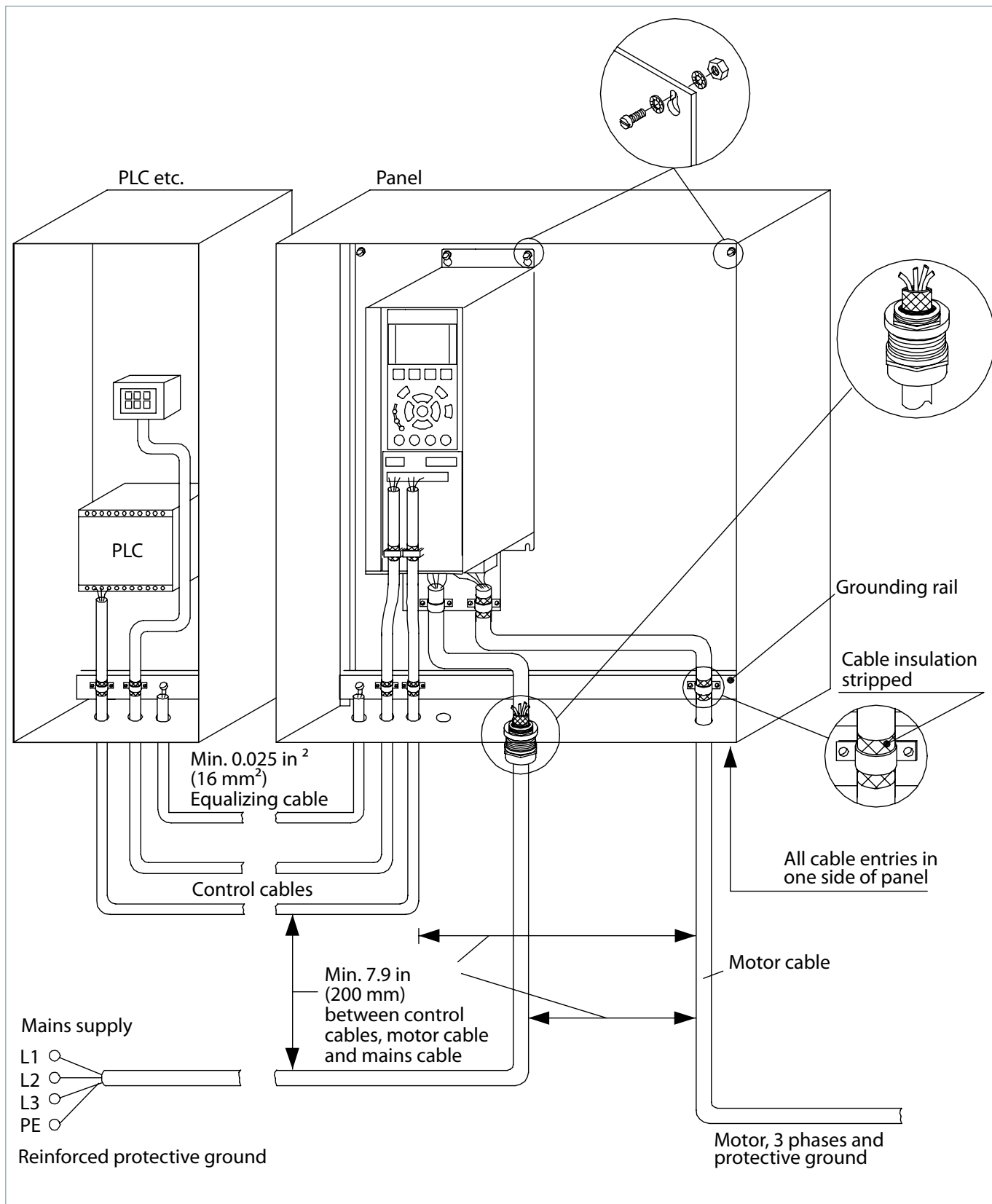

Wiring diagram

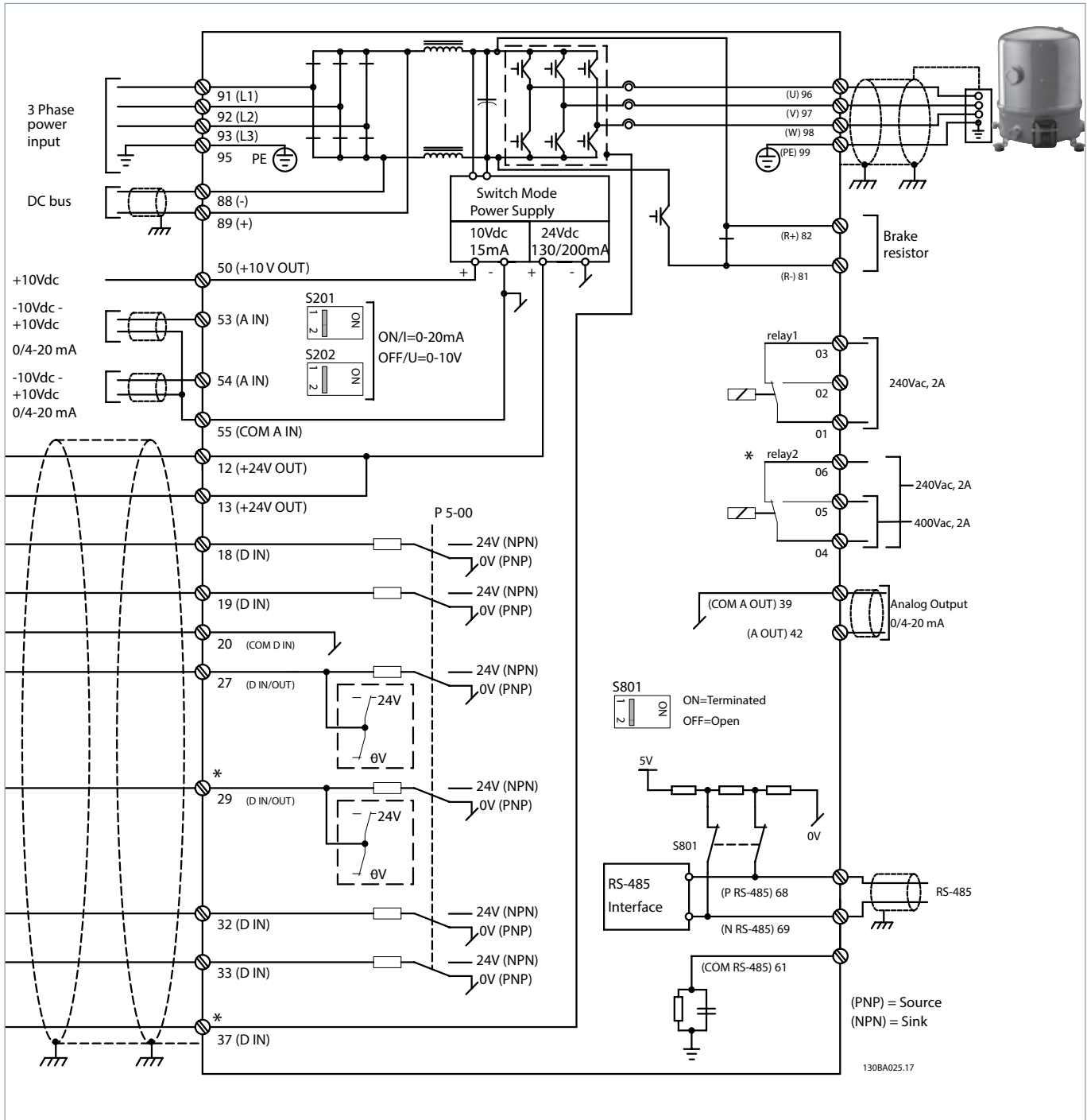

Fuses

The main power supply to the frequency converter must be done through a circuit breaker or a set of fuses, type gG. For motor code J (200-240 V) also gR type fuses may be applied.

Frequency converter	EN50178 compliant fuses		UL Compliant fuses							
	Size	Type	Bussmann			SIBA	Little fuse	Ferraz-Shawmut		
			Type RK1	Type J	Type T	Type RK1	Type RK1	Type CC	Type RK1	
200-240 V	CD-302 3K7	32 A	gG / gR	KTN-R30	JKS-30	JJN-30	5012406-32	KLN-R30	ATM-R30	A2K-30R
	CD-302 5K5	63 A	gG / gR	KTN-R50	JKS-50	JJN-50	5012406-50	KLN-R50	ATM-R50	A2K-50R
	CD-302 7K5	63 A	gG / gR	KTN-R60	JKS-60	JJN-60	5012406-63	KLN-R60	ATM-R60	A2K-60R
	CD-302 11K	80 A	gG / gR	KTN-R80	JKS-80	JJN-80	5014006-80	KLN-R80	-	A2K-80R
380-480 Volt	CD-302 3K0	20 A	gG	KTS-R15	JKS-15	JJS-15	5017906-16	KLS-R15	ATM-R15	A6K-15R
	CD-302 4K0	20 A	gG	KTS-R20	JKS-20	JJS-20	5017906-020	KLS-R20	ATM-R20	A6K-20R
	CD-302 5K5	32 A	gG	KTS-R30	JKS-30	JJS-30	5012406-32	KLS-R30	ATM-R30	A6K-30R
	CD-302 7K5	32 A	gG	KTS-R30	JKS-30	JJS-30	5012406-32	KLS-R30	ATM-R30	A6K-30R
	CD-302 11K	63 A	gG	KTS-R40	JKS-40	JJS-40	5014006-040	KLS-R40	-	A6K-40R
	CD-302 15K	63 A	gG	KTS-R50	JKS-50	JJS-50	5014006-50	KLS-R50	-	A6K-50R
	CD-302 18K	63 A	gG	KTS-R60	JKS-60	JJS-60	5014006-63	KLS-R60	-	A6K-60R

Supply voltage

Because VTZ compressors are powered by a frequency converter, the mains frequency, 50 or 60 Hz, is no longer an issue. Only the mains voltage is to be taken into account. Two motor

voltage codes are available. Never connect the VTZ compressor directly to the mains power supply.

Compressor voltage code	Frequency converter mains voltage range
J	200-240 V / 3 ph / 50 Hz & 200-240 V / 3 ph / 60 Hz
G	380-480 V / 3 ph / 50 Hz & 380 - 480 V / 3 ph / 60 Hz

Operating voltage range

The compressor operating voltage limits are directly managed by the CD302 frequency converter generating a constant voltage /

frequency ratio. This ratio is factory preset in the frequency converter corresponding to the compressor motor design.

Wiring connections

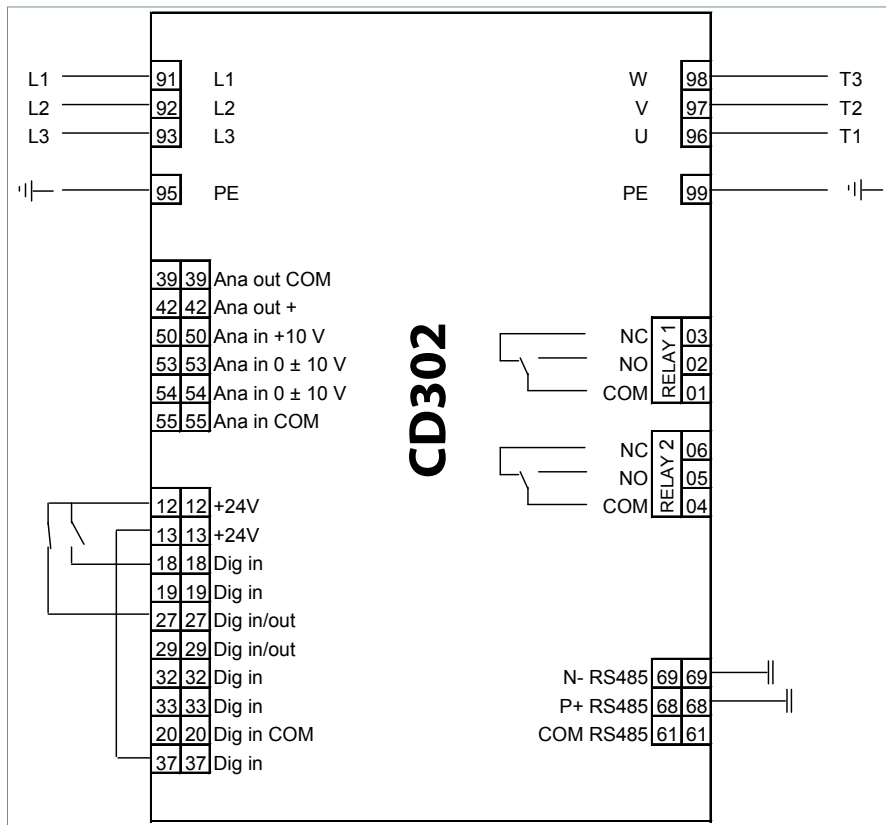

- Legends:
- Ana: Analogue
 - Dig: Digital
 - in: Input
 - out: Output
 - COM: Common
 - NC: Normally-closed
 - NO: Normally-open

		Open loop	Process loop
91, 92, 93	3 Phase mains input	X	X
95	Earth	X	X
39, 42	Analogue output	-	-
50	Analogue input	-	-
53	PLC+ (0 to 10 V)	X	-
54	Sensor -	-	X
55	PLC-	X	-
12	HP/LP switch	X	X
12	External On/Off (NO)	X	X
13	Factory bridged to 37	X	X
13	Sensor +	-	X
18	External On/Off (NO)	X	X
19	Digital input	-	-
27	HP/LP switch (NC) / safety devices	X	X
29	Digital input/output	-	-
32, 33	Digital input	-	-
20	Digital input Common	-	-
37	Factory bridged to 13	X	X
98	To compressor terminal T3	X	X
97	To compressor terminal T2	X	X
96	To compressor terminal T1	X	X
99	To compressor earth connection	X	X
02, 01	Relay 1	-	-
06, 05, 04	Relay 2	-	-
69, 68	RS485 Bus	-	-
61	RS485 Bus Common	-	-

- : Optional connection
 X : Mandatory connection

The CD302 frequency converter is factory preset with parameters for the open loop control principle. The process loop control principle can be selected by changing parameters in the «Quick menu».

Open loop: preset on input 53
 0 - 10 V control
 Frequency converter in slave mode

Process loop: preset on input 54
 4 - 20 mA control
 Frequency converter under own PID controller

Electrical connections

Electrical power is connected to the compressor terminals by Ø 4.8 mm (3/16") screws. The maximum tightening torque is 3 Nm. Use a 1/4" ring terminal on the power leads.

The cable gland has to be of EMC design to garanty a good grounding of the armored cable. Paint free areas on electrical box allow correct ground continuity.

Soft-start control

The CD302 frequency converter generates by design a compressor soft start with an initial ramp up of 0.54 sec.
Current inrush is at highest the frequency converter maximum current.

Basically seen from the mains the inrush peak reach a level which is only a few percent more than the rated nominal current.

Phase sequency and reverse rotation protection

The CD302 frequency converter is preset to run the VTZ compressors clockwise so the only care is to well connect the CDS302 output to the compressor connectors:

- CD302 terminal U (96) to VTZ terminal T1
- CD302 terminal V (97) to VTZ terminal T2
- CD302 terminal W (98) to VTZ terminal T3

Mains connection to the CD302 frequency converter order has no influence on the output phase sequence which is managed by the frequency converter.

IP rating

The compressor terminal box IP rating according to CEI529 is IP54 when correctly sized IP54 rated cable glands are used.

Motor protection

The CD302 frequency converter does not only control the compressor speed, but it provides effective compressor protection as well.

The CD302 has a built-in over-current protection. When a too high current is detected, for example by working outside the application envelope, the frequency converter immediately adjusts the compressor to a lower speed. The speed can be decreased down to the minimum value as in the setup parameters. When this value is reached, the CD302 stops the compressor. The compressor will re-start automatically after a given delay as in the set-up parameters. When this type of over-current stops has occurred more often than the pre-set maximum (parameter 14.20) the compressor can only be re-started manually.

In case of quasi sudden overloads (locked rotor, liquid slugging...) another protection is activated that can only be reset manually.

The CD302 frequency converter allows over-modulation; the frequency converter can compensate the motor torque at a drop of up to 10% of mains voltage and continue operation down to 85% of nominal mains voltage.

The CD302 frequency converter allows to manage low and high current. This function automatically adjusts the motor speed to match motor current to nominal values. Note: Current draw to the VTZ compressor remains close to constant for a given refrigeration working load over the full speed range.

Voltage imbalance

The maximum allowable voltage imbalance between each phase is 3%. Voltage imbalance causes high amperage over one or several phases, which in turn leads to overheating and possible drive damage.

Mains imbalance function in CD302 frequency converter can be set to "[0] Trip" or "[1] Warning" in 14.12 parameter. It is, by default, factory preset to "[1] Warning".

Ambient temperature and altitude

The normal ambient temperature supported by the frequency converter covers a range from -10°C to +50°C without any issue or derating. Anyhow, the frequency converter will operate normally down to -20°C where only the screen of the LCP (if installed) will show display issues which will not be damaged.

For ambient temperatures above +50°C, it is mandatory to integrate a derating output factor for the maximum compressor electrical motor power/current. The derating values are shown in the drive application manual and are linked to the drive frame and IP protection level.

For altitude below 1000m, the frequency converter will be able to deliver 100% output power under full load for above ambient temperature. However, for altitude above 1000m derating must be applied like shown on the table below.

Altitude	Derating factor
1000 m	1
1500 m	0,95
2000 m	0,9
2500 m	0,86
3000 m	0,82
3500 m	0,78

For more details about these specific running conditions, please contact Danfoss technical support.

The various system components shall be selected to cover flow rate and capacity at any expected operating condition. A refrigeration system that includes a inverter driven compressor generates a refrigerant mass flow

that varies in relation to the thermal load. To keep this system working with accurate parameters all components must be able to handle this capacity fluctuation (evaporator, condenser, expansion devices, piping, etc.).

Piping design

Oil in a refrigeration circuit is required to lubricate moving parts in the compressor. During normal system operation small oil quantities will continuously leave the compressor, with the discharge gas. With good system piping design this oil will return to the compressor. As long as the amount of oil circulating through the system is small it will contribute to good system operation and improved heat transfer efficiency. However, too large amounts of oil in the system will have a negative effect on condenser and evaporator efficiency. If, in a poorly designed system, the amount of oil returning to the

compressor is lower than the amount of oil leaving the compressor, the compressor will become starved of oil and the condenser, evaporator and/or refrigerant lines will become filled with oil. In such situations, additional oil charge will only correct the compressor oil level for a limited period of time and increase the amount of surplus oil in the rest of the system.

Only correct piping design and oil system management including oil separator, oil reservoir and oil level regulator can ensure a good oil balance in the system.

Suction lines

Horizontal suction line sections shall have a slope of 0.5% in the direction of refrigerant flow (5 mm per meter). The cross-section of horizontal suction lines shall be such that the resulting gas velocity is at least 4 m/s. In vertical risers, a gas velocity of 8 to 12 m/s is required to ensure proper oil turn. A U-trap is required at the foot of each vertical riser. If the riser is higher than 4 m, additional U-traps are needed for each additional 4 meters. The length of each U-trap must be as short as possible to avoid the accumulation of excessive quantities of oil (see figure below).

The common suction riser should be designed as a double riser. Also refer to the News bulletin "Mounting instructions for installation of Maneurop® compressors in parallel" and "Parallel application guidelines".

Gas velocities higher than 12 m/s will not contribute to significantly better oil return. However they will cause higher noise levels and result in higher suction line pressure drops which will have a negative effect on the system capacity.

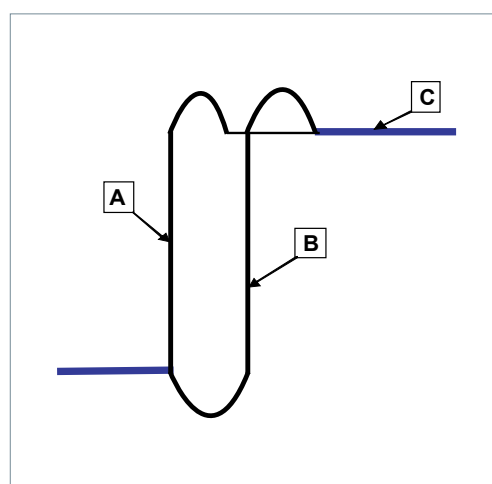
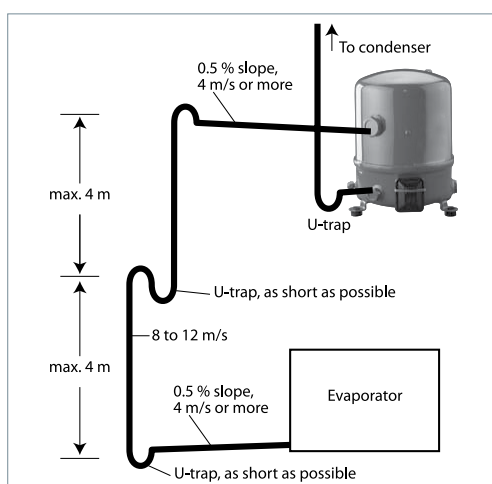

Suction pipe selection exemple		VTZ038	VTZ054	VTZ086	VTZ121	VTZ171	VTZ215	VTZ242
VTZ R404A (-10/+45°C)	Mini riser (A)	1/2"	1/2"	5/8"	3/4"	7/8"	1"1/8	1"1/8
	Max riser (B)	5/8"	3/4"	7/8"	1"1/8	1"3/8	1"3/8	1"3/8
	Suct. header (C)	3/4"	7/8"	1"1/8	1"3/8	1"5/8	1"5/8	1"5/8

Note that the suction rotolock valves, which can be ordered from Danfoss as accessories, are designed for average pipe sizes, selected for systems running at nominal conditions. The pipe

sizes selected for specific systems may differ from these recommended sizes. It is recommended that the suction lines are insulated to limit superheat.

Discharge line

When the condenser is mounted above the compressor, a loop above the condenser and a U-trap close to the compressor are required to prevent liquid draining from the condenser into the discharge line during standstill.

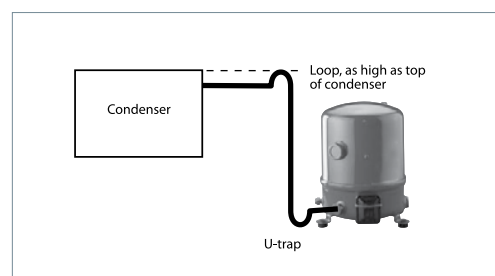
Filter driers

For new installations with VTZ compressors Danfoss recommends using the Danfoss DML 100% molecular sieve, solid core filter drier. Molecular sieve filter driers with loose beads from third party suppliers shall be avoided. For servicing of existing installations where acid formation is present the Danfoss DCL solid core filter driers containing activated alumina are recommended.

The drier is to be oversized rather than undersized. When selecting a drier, always take into account its capacity (water content capacity), the system refrigerating capacity and the system refrigerant charge.

Liquid refrigerant control and charge monitoring

Refrigeration compressors are basically designed as gas compressors. Depending on the compressor design and operating conditions, most compressors can also handle a limited amount of liquid refrigerant. Maneurop® VTZ compressors have a large internal volume and can therefore handle relatively large amounts of liquid refrigerant without major problems. However even when a compressor can handle liquid refrigerant this will not be favourable to its service life. Liquid refrigerant can dilute the

oil, wash oil out of bearings and result in high oil carry over, resulting in loss of oil from the sump. Good system design can limit the amount of liquid refrigerant in the compressor, which will have a positive effect on the compressor service life.

Liquid refrigerant can enter a compressor in different ways, with different effects on the compressor.

Off-cycle migration

During system standstill and after pressure equalisation, refrigerant will condense in the coldest part of the system. The compressor can easily be the coldest spot, for example when it is placed outside in low ambient temperatures. After a while, the full system refrigerant charge can condense in the compressor crankcase. A large amount will dissolve in the compressor oil until the oil is completely saturated with refrigerant. If other system components are located at a higher level, this process can be even faster because gravity will assist the liquid refrigerant to flow back to the compressor. When the compressor is started, the pressure in the crankcase decreases rapidly.

At lower pressures the oil holds less refrigerant, and as a result part of the refrigerant will violently evaporate from the oil, causing the oil to foam.

This process is often called "boiling". The negative effects from migration on the compressor are:

- oil dilution by liquid refrigerant
- oil foam, transported by refrigerant gas and discharged into the system, causing loss of oil and in extreme situations risk for oil slugging
- in extreme situations with high system refrigerant charge, liquid slugging could occur (liquid entering the compressor cylinders)

Liquid floodback during operation

During normal and stable system operation, refrigerant will leave the evaporator in a superheated condition and enter the compressor as a superheated vapour.

Normal superheat values at compressor suction are 5 to 30 K. However the refrigerant leaving

the evaporator can contain an amount of liquid refrigerant due to different reasons:

- wrong dimensioning, wrong setting or malfunction of expansion device
 - evaporator fan failure or blocked air filters.
- In these situations, liquid refrigerant will continuously enter the compressor.

	<p>The negative effects from continuous liquid floodback are:</p> <ul style="list-style-type: none"> • permanent oil dilution 	<ul style="list-style-type: none"> • in extreme situations with high system refrigerant charge and large amounts of floodback, liquid slugging could occur.
Liquid floodback at change over cycles in reversible heat pumps	<p>In heat pumps, change over from cooling to heating cycles, defrost and low load short cycles may lead to liquid refrigerant floodback or saturated refrigerant return conditions.</p>	<p>The negative effects are :</p> <ul style="list-style-type: none"> • oil dilution • in extreme situations with high system refrigerant charge and large amounts of floodback, liquid slugging could appear.
Liquid floodback and zeotropic refrigerants	<p>Liquid floodback in systems working with a zeotropic refrigerant such as R407C introduces additional negative effects. A part of the refrigerant leaves the evaporator in liquid phase and this liquid has a different composition than the vapour.</p>	<p>This new refrigerant composition may result in different compressor operating pressures and temperatures.</p>
Crankcase heater	<p>A crankcase heater protects against the off-cycle migration of refrigerant and proves effective if oil temperature is maintained 10 K above the saturated LP temperature of the refrigerant. Tests must thereby be conducted to ensure that the appropriate oil temperature is maintained under all ambient conditions. A PTC crankcase heater is recommended on all stand-alone compressors and split systems. PTC crankcase heaters are self-regulating.</p> <p>Under extreme conditions such as very low ambient temperature a belt type crankcase heater could be used in addition to the PTC heater, although this is not a preferred solution for 1 and 2 cylinder compressors. The belt crankcase heater must be positioned on the</p>	<p>compressor shell as close as possible to the oil sump to ensure good heat transfer to the oil.</p> <p>Belt crankcase heaters are not self-regulating. Control must be applied to energise the belt heater once the compressor has been stopped and then to de-energise it while the compressor is running. The belt heater must be energised 12 hours before restarting the compressor following an extended down period. If the crankcase heater is not able to maintain the oil temperature at 10 K above the saturated LP temperature of the refrigerant during off cycles or if repetitive floodback is present at each start of the compressor, then pump-down cycle is required, eventually in conjunction with a suction accumulation</p>
Liquid line solenoid valve & pump-down	<p>In refrigeration applications, the Liquid Line Solenoid Valve (LLSV) is highly recommended. During the off-cycle, the LLSV isolates the liquid charge in the condenser side, thus preventing against refrigerant transfer or excessive migration of refrigerant into the compressor. Furthermore, when using a LLSV in conjunction</p>	<p>with a pump-down cycle, the quantity of refrigerant in the low-pressure side of the system will be reduced.</p> <p>A pump-down cycle design is required when evaporators are fitted with electric defrost heaters.</p>
Suction accumulator	<p>A suction accumulator offers considerable protection against refrigerant floodback at start-up, during operation or after the defrost operation. This device also helps to protect against off-cycle migration by means of providing additional internal free volume to the low pressure side of the system.</p> <p>The suction accumulator must be selected in accordance with the accumulator manufacturer</p>	<p>recommendations. As a general rule, Danfoss recommends to size the accumulator for at least 50% of the total system charge. Tests however must be conducted to determine the optimal size.</p> <p>When the superheat cannot be safely managed, a suction accumulator should be used. R407C is not recommended in these applications as there is a risk of refrigerant composition shift.</p>

Vibration

The mounting grommets delivered with the compressor should always be used. They reduce the vibration transmitted by the compressor mounting feet to the base frame.

The base on which the compressor is mounted should be sufficiently rigid and of adequate mass to ensure the full effectiveness of the mounting grommets.

The compressor should never be directly mounted to the base frame without the grommets, otherwise high vibration transmission would occur and the compressor service life reduced. Suction and discharge lines must have adequate flexibility in 3 planes. Eventually vibration absorbers may be required.

Care must be taken to avoid tubing having resonant frequencies close to those of the compressor frequency.

Vibration is also transmitted by the refrigerant pulsation gas. VTZ compressors have built in mufflers to reduce these pulsations.

To further reduce vibration one extra muffler can be installed.

Note: VTZ compressors have been designed and qualified for stationary equipment used in A/C and Refrigeration applications. Danfoss doesn't warrant these compressors for use in mobile applications, such as trucks, railways, subways, etc...

Evaporator

When the evaporator is dimensioned for nominal conditions, it becomes undersized when the compressor speed increases. The evaporating temperature will tend to drop.

To achieve a more energy efficient system it's worthwhile to increase the heat transfer capacity by increasing the external flow. In general, one

should adapt the external flow proportionally and simultaneously to the refrigerant mass flow. This implies inverter for pumps or fans in secondary systems. This principle is similar for low load where the flow of the secondary medium can be reduced to achieve energy savings by reduced motor power consumption.

Condenser

VTZ cooling capacity is closely related to rotational speed. It is recommended to control the condensing temperature in order to limit power consumption rise during heat load increase. Control of condensing temperature has the effect of reducing the compressor power consumption and also leads to increased cooling capacity by increased thermal effect. At the same time motor consumption of condenser pump or fans is also decreased.

We recommend to vary condensing pressure by keeping a constant difference between condensing temperature and ambient temperature. This solution combined with speed control offers the best energy savings. Note however that condensing temperature shall not drop below 20°C.

Defrosting using reverse cycle

In general it is recommended to drive the compressor between 3000 – 3600 rpm during defrost. However, the defrost duration may be reduced by increasing the compressor speed. When coming back to the normal working cycle after a defrost, the compressor

must run at minimum speed during one or two minutes to minimize the risk for liquid slugging. If the system refrigerant charge is higher than the compressor charge limit it is strongly recommended to use a liquid suction accumulator.

Oil circulation rate and oil level management

The oil circulation rate is proportional to the rotational speed of the compressor. It is therefore an essential parameter when designing an inverter compressor system. The below graph shows that highest OCR values occur at maximum speed. Oil level in the compressor must be maintained at every operating frequency in order to avoid compressor damage. When uncontrolled amounts of lubricant are in circulation in the heat exchangers, the heat transfer will be reduced. Furthermore it can disturb line control components such as the expansion valve.

The amount of oil circulating in the system can be limited with an oil separator. This component is mandatory for systems with long pipe runs and/or a high refrigerant charge. For compact

systems an oil separator is not always needed but confirmation tests have to be done.

The oil separator selection shall be done based on the manufacturers documentation ensuring adequate oil return to the compressor sump. The oil separator must maintain a correct oil level in the compressor at any working condition. Note that the installation of an oil separator implies topping the oil quantity in the system.

When applying the VTZ inverter compressor in a rack system, it is recommended to use an individual oil level controller per compressor in combination with a common oil separator and oil reservoir.

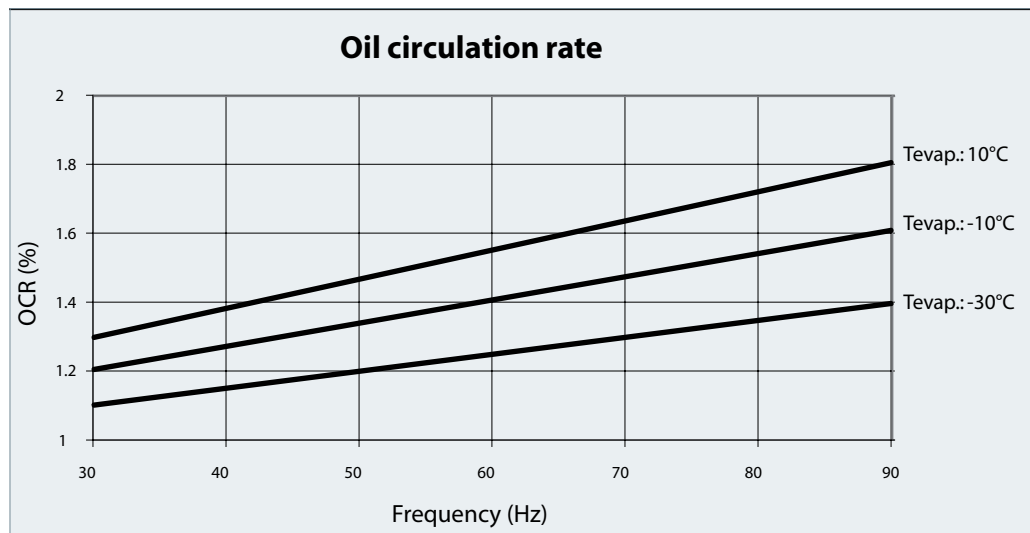

System cleanliness

System contamination is one of the main factors affecting equipment reliability and compressor service life.

Therefore it is important to ensure system cleanliness when manufacturing a refrigeration system. During the manufacturing process, system contamination can be caused by:

- Brazing and welding oxides
- Filings and particles from removing burrs from pipe-work
- Brazing flux
- Moisture and air.

Only use clean and dehydrated refrigeration grade copper tubes and silver alloy brazing

material. Clean all parts before brazing and always purge nitrogen or CO₂ through the pipes during brazing to prevent oxidation. If flux is used, take every precaution to prevent leakage into the piping. Do not drill holes (e.g. for Schrader valves) in parts of the installation that are already completed, when filings and burrs can not be removed. Carefully follow the instructions below regarding brazing, mounting, leak detection, pressure test and moisture removal. All installation and service work shall only be done by qualified personnel respecting all procedures and using tools (charging systems, tubes, vacuum pump, etc.) dedicated for the refrigerant that will be used.

Compressor handling

Maneurop® VTX compressors are provided with a lifting lug. This lug should always be used to lift the compressor. Once the compressor is installed, the compressor lifting lug should never be used to lift the complete installation.

Keep the compressor in an upright position during handling.

Compressor mounting

Mount the compressor on a horizontal plane with a maximum slope of 3 degrees. All compressors are supplied with three or four rubber mounting grommets, each complete with metal sleeves and nuts and bolts. Refer to the outline drawings.

These grommets largely attenuate the compressor vibration transmitted to the base frame. The compressor must always be mounted with these grommets. Refer to the table below for torque values.

Connection		Recommended torque (Nm)
Cable screw of T connector in electrical box	Screw 10/32 - UNF x 3	3
Rotolock valves and solder sleeves	1"	80
	1"1/4	90
	1"3/4	110
Mounting grommet	1 – 2 – 4 Cylinder	15
Oil sight glass	-	50
Oil equalisation connection	1 – 2 – 4 Cylinder	30

Compressor connection to system

New compressors have a protective nitrogen holding charge. The suction and discharge caps should only be removed just before connecting the compressor to the installation to avoid air and moisture entering the compressor.

Whenever possible the compressor must be the last component to be integrated in the system. It

is advisable to braze the solder sleeves or service valves to the pipe work before the compressor is mounted. When all brazing is finished and when the total system is ready, the compressor caps can be removed and the compressor can be connected to the system with a minimum exposure to ambient air.

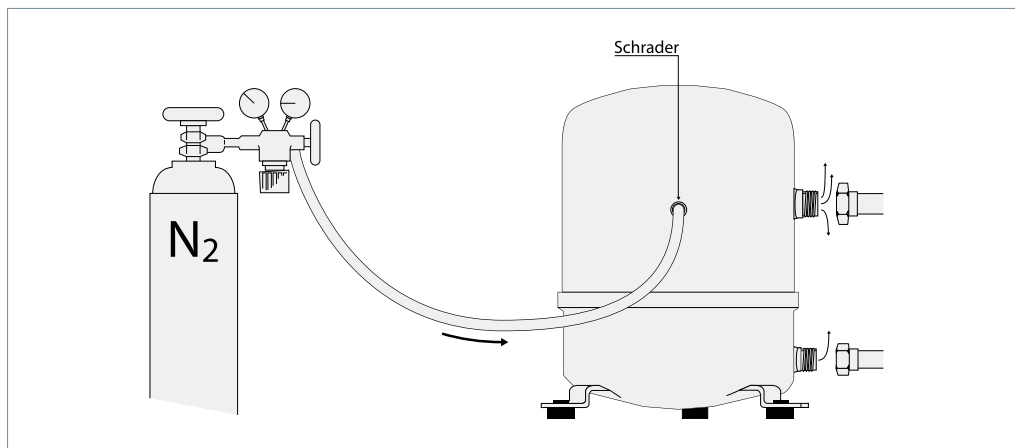

If this procedure is not possible, the sleeves or valves may be brazed to the pipes when mounted on the compressor.

In this situation nitrogen or CO2 must be purged through the compressor via the Schrader valve to prevent air and moisture ingress. Purging must start when the caps are removed and preceded during the brazing process.

When rotolock valves are used on the compressor, they shall be closed immediately

after mounting, thus keeping the compressor isolated from atmosphere or from a not yet dehydrated system.

Note : When the compressor is built into a "pack" or "rack" configuration which is not installed immediately on its final location, a vacuum pull-down and moisture removal must be performed to this pack (rack) as if it were a complete system (see below). The pack must be charged with nitrogen or CO2 and open tubes must be blocked with caps or plugs.

System pressure test

It is recommended that an inert gas such as nitrogen be used for pressure testing. Dry air may also be used but care should be taken since it can form an inflammable mixture with the compressor oil. When performing a system pressure test, the maximum allowed pressure for the different components should not be exceeded.

Maximum compressor test pressure, low side	25 bar(g)
Maximum compressor test pressure, high side	30 bar(g)

Leak detection

Whenever possible (if valves are present) the compressor must be kept isolated from the system. Perform a leak detection using the final refrigerant. Pressurise with nitrogen or another neutral gas and use a leak detector for the applied refrigerant. Any spectrometric detection system using helium can also be applied.

Eventual leaks shall be repaired respecting the instructions written above. It is not recommended to use other gasses such as oxygen, dry air or acetylene as these gasses can

form an inflammable mixture. Never use CFC or HCFC refrigerants for leak detection of HFC systems.

Note 1: Leak detection with refrigerant may not be allowed in some countries. Check local regulations.

Note 2: Leak detecting additives shall not be used as they may affect the lubricant properties. Warranty may be voided if leak detecting additives have been used.

Vacuum pull-down moisture removal

Moisture obstructs the proper functioning of the compressor and the refrigeration system.

Air and moisture reduce service life and increase condensing pressure, and cause excessively high discharge temperatures, which can destroy the

lubricating properties of the oil. Air and moisture also increase the risk of acid formation, giving rise to copper plating. All these phenomena can cause mechanical and electrical compressor failure.

To eliminate these factors, a vacuum pull-down according to the procedure below is recommended:

1. Whenever possible (if valves are present) the compressor must be kept isolated from the system.
2. After the leak detection, the system must be pulled-down under a vacuum of 500 microns (0.67 mbar). A two stage vacuum pump shall be used with a capacity appropriate to the system volume. It is recommended to use connection lines with a large diameter and to connect these to the service valves and not to the Schrader connection to avoid too high pressure losses.
3. When the vacuum level of 500 micron is reached, the system must be isolated from the vacuum pump. Wait 30 minutes during which the system pressure should not rise. When the pressure rapidly increases, the system is not

leak tight. A new leak detection must be performed and the vacuum pull-down procedure should be restarted from step 1. When the pressure slowly increases, this indicates the presence of moisture. In this case step 2 and 3 should be repeated.

4. Connect the compressor to the system by opening the valves. Repeat step 2 and 3.
5. Break the vacuum with nitrogen or the final refrigerant.
6. Repeat step 2 and 3 on the total system. At commissioning, system moisture content may be up to 100 ppm. During operation the filter drier must reduce this to a level < 20 ppm.

Warning: do not use a megohmmeter or apply power to the compressor while it is under vacuum, as this may cause motor winding damage. Never run the compressor under vacuum as it may cause compressor motor burn-out.

Start-up

Before initial start-up or after a prolonged shut down period, energise the crankcase heater (if fitted) 12 hours prior to start-up.

Refrigerant charging

Installations exist in a multiple of designs and with many possible system components installed. The system design and the presence or absence of certain components, not only influence the system behaviour during operations; they can also be of a great influence during the refrigerant charging procedure. Improper charging procedure could cause compressor damage in several ways excessive LP/HP pressure differences, liquid slugging or vacuum operation. The below charge procedure is strongly recommended to reduce these risks.

Prior to refrigerant charging a system vacuum and moisture removal procedure must have been carried out.

Always use a scale to measure actual refrigerant charge quantity. Record system charge when completed.

The refrigerant must be charged in the liquid phase at the liquid side of the refrigeration circuit. The best charging location is the service shut-off valve at the liquid receiver outlet. When there is no liquid receiver, the charge must be done in the liquid line. When a liquid line solenoid valve (LLSV) is present, it must be closed (de-energised) and the charge location must be before the LLSV.

If the system is equipped with an electronic expansion valve (EXV), this valve must be fully closed (opening degree: 0%).

Loosely connect the service manifold HP hose to a gauge fitting on the liquid side as described above. Connect the LP hose to a fitting on the suction line as far away as possible from the compressor.

The compressor must be off and prevented from starting inadvertently/automatically.

If the service manifold HP gauge is connected to a liquid line service shut-off valve, put this valve in an intermediate position (between front seat and back seat).

Start the charging process:

- Using a charging machine the refrigerant charge specified can be achieved in one step
- If using a refrigerant cylinder, it can be warmed up carefully to avoid generating over pressure, but increase enough the tank pressure to allow the complete transfer.
- If neither EXV nor LLSV is present, take extra care not filling up the compressor sump with liquid refrigerant via the evaporator and suction line.

“Crack” open the LP service gauge manifold valve. The pressure in the system LP side increase slowly until LP pressure equals HP pressure. The pressure increase at LP side shall not be faster than 0.25 bar/second. A brutal pressure increase can cause internal compressor damage because of an excessive LP/HP compressor side difference.

Application Guidelines

Installation

Compressor can be started. Make sure the compressor is not going to run under vacuum. If this situation appears then manually stop and restart the compressor. When a EXV is used it can be prepositioned at given opening degree to avoid running at low evaporating during EXV self adjustment. Never by-pass the LP pressure switch.

Allow the system to operate until the design operating temperature has been achieved before making final refrigerant charge adjustment.

The additional refrigerant charge must be done on the LP side by slowly throttling through the Schrader fitting.

Continue to monitor the system closely throughout the entire, initial pull-down period. Observe all operating system pressures and temperatures and make any other necessary control adjustments. During this time, the compressor oil level should be maintained within the sight glass and suction superheat measured at the compressor suction to ensure adequate motor cooling and no liquid refrigerant is being returned directly to the compressor.

Commissioning

The system must be monitored after initial start-up for a minimum of 60 minutes to ensure proper operating characteristics such as:
 Proper metering device operation and desired superheat readings
 Suction and discharge pressure are within acceptable levels
 Correct oil level in compressor sump indicating proper oil return.

Low foaming in sight glass and compressor sump temperature 10K above saturation temperature to show that there is no refrigerant migration taking place
 Acceptable cycling rate of compressors, including duration of run times
 Current draw of compressor within acceptable values (current can be displayed on the LCP)
 No abnormal vibrations and noise.

Oil level checking and top-up

In installation with good oil return and line runs up to 20 metres no additional oil is required. If installation lines exceed 20 m, additional oil may be needed. 2% of the total system refrigerant charge (in weight) can be used to roughly define the required oil top-up quantity but in any case the oil adjustment has to be based on the oil level in the compressor sight glass. This procedure must be conducted with the system running at high load (compressor at full speed).

speed, for a minimum duration of 1 hour. The oil level must be always visible at the compressor sight glass. If any deviation is observed, this means that some oil is trapped in the system, heat exchangers and/or pipes.

When the compressor is running under stabilised conditions the oil level must be visible in the sight glass.

Oil level check must always be done compressor running. When the compressor is off, the level in the sight glass is influenced by the presence of refrigerant in the oil.

Mandatory check is made at low load and stabilised conditions, compressor at minimum

Top-up the oil with compressor running. Use the Schrader connector or any other accessible connector on the compressor suction line and a suitable pump. See dedicated bulletin "Lubricants filling in instructions for Danfoss Commercial Compressors".

Suction gas superheat

The optimum suction gas superheat is 8 K. A lower superheat value will contribute to better system performance (higher mass flow and more efficient use of evaporator surface). Low super-heat values however increase the risk of unwanted liquid floodback to the compressor. For very low superheat values an electronically controlled expansion valve is recommended.

The maximum allowable superheat is about 30 K. Higher values can be accepted but in these cases, tests have to be performed to check that the maximum discharge temperature of 130°C will not be exceeded. Note that high superheat values decrease the compressor application envelope and system performance.

Programming

For programming and adjusting the CD302 frequency converter see the installation instruction reference 85.10.233.

Application Guidelines Ordering information and packaging

Kit ordering and shipping The tables on the following pages give code numbers for ordering. Note that VTZ compressors and CD302 frequency converters

are packed and shipped separately and must also be ordered separately.

Packaging



Model	Single pack			Multipack				Industrial pack			
	Dimensions (mm)	Gross weight (kg)	Nbr	Dimensions (mm)	Gross weight (kg)	Static stacking	Nbr	Dimensions (mm)	Gross weight (kg)	Static stacking	
1 cyl.	VTZ038	l: 330 w: 295 h: 385	23	8	l: 1150 w: 800 h: 510	197	4	12	l: 1150 w: 800 h: 500	278	4
	VTZ054		26			221				314	
2 cyl.	VTZ086	l: 395 w: 365 h: 455	37	6	l: 1150 w: 800 h: 600	232	4	6	l: 1150 w: 800 h: 600	224	4
	VTZ121		42			262				254	
4 cyl.	VTZ171	l: 570 w: 400 h: 670	70	4	l: 1150 w: 800 h: 820	291	4	6	l: 1150 w: 800 h: 710	381	4
	VTZ215		73			303				399	

Single pack: One compressor in a cardboard box. In some publications this packaging may be indicated as 'individual packaging.'

Multipack: A full pallet of compressors, each individually packed in a cardboard box. Mainly dedicated to wholesalers and Danfoss distribution centers.

Industrial pack: A full pallet of unpacked compressors. Mainly dedicated to OEM customers. In some publications this packaging may be indicated as 'Multiple packaging.'

Nbr: Number of compressor in a pack

Frequency converter single pack

Dimensions are given with drives in delivery position, without black plastic pallet.

CD302 packaging

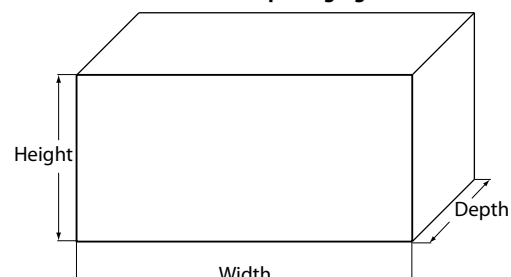

Drive supply voltage	Drive supply voltage code	Drive power (kW)	IP20			IP21			IP55		
			Drive enclosure	Overall dimension (hxwxD) mm	Weight (kg)	Drive enclosure	Overall dimension (hxwxD) mm	Weight (kg)	Drive enclosure	Overall dimension (hxwxD) mm	Weight (kg)
200-240/3/50-60	T2	3.7	A3	290x390x200	6.6	-	-	-	B1	346x810x320	23
		5.5	-	-	-	B1	346x810x320	23	B1	346x810x320	23
		7.5	-	-	-	B1	346x810x320	23	B1	346x810x320	23
		11	-	-	-	B2	346x810x320	28	B2	346x810x320	28
380-480/3/50-60	T4	4	A2	290x390x160	5	-	-	-	A5	335x550x280	15
		5.5	A3	290x390x200	6.6	-	-	-	A5	335x550x280	15
		7.5	A3	290x390x200	6.6	-	-	-	A5	335x550x280	15
		11	B3	349x500x330	13	B1	346x810x320	23	B1	346x810x320	23
		15	B3	349x500x330	13	B1	346x810x320	23	B1	346x810x320	23
		18.5	-	-	-	B2	346x810x320	28	B2	346x810x320	28

**VTZ voltage code G
380-480 volt and CD302**

Model	Compressor		Model & power	Frequency converter			
	Code number for ordering			IP class	RFI class	LCP	Order code
	Single pack	Industrial pack					
VTZ038-G	120B0001	NA	CD302 4.0kW	IP20	H1	yes	131B3543
						no	131B3544
VTZ054-G	120B0002	NA	CD302 5.5kW	IP20	H1	yes	131B3552
						no	131B3553
VTZ086-G	120B0003	120B0054	CD302 7.5kW	IP20	H1	yes	131B3560
						no	131B3561
VTZ121-G	120B0004	120B0052	CD302 11.0kW	IP55	H1	yes	131B3564
						no	131X2198
VTZ171-G	120B0005	120B0054	CD302 15.0kW	IP20	H1	yes	131B3568
						no	131B3569
VTZ215-G	120B0006	120B0056	CD302 18.5kW	IP21	H1	yes	131B3572
						no	131X2199
VTZ171-G	120B0005	120B0054	CD302 15.0kW	IP21	H1	yes	131B3576
							no
VTZ171-G	120B0005	120B0054	CD302 15.0kW	IP21	H2	yes	131B3578
							no
VTZ215-G	120B0006	120B0056	CD302 18.5kW	IP55	H1	yes	131B3580
						no	131B3584
VTZ215-G	120B0006	120B0056	CD302 18.5kW	IP21	H1	yes	131B3584
						no	131B3585
VTZ215-G	120B0006	120B0056	CD302 18.5kW	IP55	H1	yes	131B3588
						no	131B3588

**VTZ voltage code J
200-240 volt and CD302**

Model	Compressor		Frequency converter				
	Code number for ordering		Model & power	IP class	RFI class	LCP	Order code
	Single pack	Industrial pack					
VTZ038-J	120B0029	NA	CD302 3.7kW	IP20	H1	yes	131B5347
			CD302 5.5kW	IP55	H1	yes	131B5353
VTZ054-J	120B0030	NA	CD302 5.5kW	IP21	H1	yes	131B5351
				IP55	H1	yes	131B5353
VTZ086-J	120B0031	NA	CD302 7.5kW	IP21	H1	yes	131B5009
				IP55	H1	yes	131B5361
VTZ121-J	120B0032	120B0057	CD302 11.0kW	IP21	H1	yes	131B5365
				IP55	H1	yes	131B5369

Valves, adapters, connectors & gaskets for use on suction and discharge connections
Rotolock service valves and valve sets (without gasket)

Type	Code n°	Description	Application	Packaging	Pack size
V06	8168031	Rotolock valve, V06 (1" Rotolock, 1/2" ODF)	Models with 1" rotolock connection	Multipack	6
V04	8168029	Rotolock valve, V04 (1"1/4 Rotolock, 3/4" ODF)	Models with 1"1/4 rotolock connection	Multipack	6
V04	7968006	Rotolock valve, V04 (1"1/4 Rotolock, 3/4" ODF)		Industry pack	42
V05	8168030	Rotolock valve, V05 (1"1/4 Rotolock, 7/8" ODF)	Models with 1"1/4 rotolock connection	Multipack	6
V05	7968007	Rotolock valve, V05 (1"1/4 Rotolock, 7/8" ODF)		Industry pack	36
V09	8168033	Rotolock valve, V09 (1"1/4 Rotolock, 5/8" ODF)	Models with 1"1/4 rotolock connection	Multipack	6
V09	7968005	Rotolock valve, V09 (1"1/4 Rotolock, 5/8" ODF)		Industry pack	50
V02	8168028	Rotolock valve, V02 (1"3/4 Rotolock, 1"1/8 ODF)	Models with 1"3/4 rotolock connection	Multipack	6
V02	7968009	Rotolock valve, V02 (1"3/4 Rotolock, 1"1/8 ODF)		Industry pack	24
V07	8168032	Rotolock valve, V07 (1"3/4 Rotolock, 7/8" ODF)	Models with 1"3/4 rotolock connection	Multipack	6
V07	7968008	Rotolock valve, V07 (1"3/4 Rotolock, 7/8" ODF)		Industry pack	36
V10	8168022	Rotolock valve, V10 (1"3/4 Rotolock, 1-3/8" ODF)	Models with 1"3/4 rotolock connection	Single pack	1
V09, V06	7703005	Valve set, V09 (1"1/4~5/8"), V06 (1"~1/2")		Multipack	4
V07, V04	7703006	Valve set, V07 (1"3/4~7/8"), V04 (1"1/4~3/4")		Multipack	6
V02, V04	7703009	Valve set, V02 (1"3/4~1"1/8), V04 (1"1/4~3/4")		Multipack	6

Rotolock nuts

Type	Code n°	Description	Application	Packaging	Pack size
	8153122	Rotolock nut, 1"	Models with 1" rotolock connection	Multipack	10
	8153123	Rotolock nut, 1"1/4	Models with 1"1/4 rotolock connection	Multipack	10
	8153124	Rotolock nut, 1"3/4	Models with 1"3/4 rotolock connection	Multipack	10

Solder sleeves

Type	Code n°	Description	Application	Packaging	Pack size
P06	8153007	Solder sleeve, P06 (1" Rotolock, 1/2" ODF)	Models with 1" rotolock connection	Multipack	10
P09	8153011	Solder sleeve, P09 (1"1/4 Rotolock, 5/8" ODF)	Models with 1"1/4 rotolock connection	Multipack	10
P04	8153008	Solder sleeve, P04 (1"1/4 Rotolock, 3/4" ODF)	Models with 1"1/4 rotolock connection	Multipack	10
P05	8153012	Rotolock connector, P05 (1"1/4 Rotolock, 7/8" ODF)	Models with 1"1/4 rotolock connection	Multipack	10
P07	8153013	Solder sleeve, P07 (1"3/4 Rotolock, 7/8" ODF)	Models with 1"3/4 rotolock connection	Multipack	10
P02	8153004	Solder sleeve, P02 (1"3/4 Rotolock, 1"1/8 ODF)	Models with 1"3/4 rotolock connection	Multipack	10
P10	8153003	Solder sleeve, P10 (1"3/4 Rotolock, 1"3/8 ODF)	Models with 1"3/4 rotolock connection	Multipack	10

Gaskets and gasket set

Type	Code n°	Description	Application	Packaging	Pack size
G01	8156130	Gasket, 1"	Models with 1" rotolock connection	Multipack	10
G01	7956001	Gasket, 1"		Industry pack	50
G09	8156131	Gasket, 1"1/4	Models with 1"1/4 rotolock connection	Multipack	10
G09	7956002	Gasket, 1"1/4		Industry pack	50
G07	8156132	Gasket, 1"3/4	Models with 1"3/4 rotolock connection	Multipack	10
G07	7956003	Gasket, 1"3/4		Industry pack	50
	8156009	Gasket set	All VTZ	Multipack	10

Crankcase heaters, soft starters, protection modules, thermostats & resistors
Crankcase heaters

Type	Code n°	Description	Application	Packaging	Pack size
	7773106	Belt type crankcase heater, 54 W, 230 V, CE mark, UL	VTZ038-054	Multipack	4
	7773013	Belt type crankcase heater, 54 W, 400 V, UL		Multipack	4
	7773109	Belt type crankcase heater, 65 W, 110 V, CE mark, UL	VTZ086-121	Multipack	6
	7973001	Belt type crankcase heater, 65 W, 110 V, CE mark, UL		Industry pack	50
	7773107	Belt type crankcase heater, 65 W, 230 V, CE mark, UL		Multipack	6
	7973002	Belt type crankcase heater, 65 W, 230 V, CE mark, UL		Industry pack	50
	7773117	Belt type crankcase heater, 65 W, 400 V, CE mark, UL		Multipack	6
	120Z0466	Belt type crankcase heater, 65 W, 460 V, CE mark, UL		Multipack	6
	7773110	Belt type crankcase heater, 75 W, 110 V, CE mark, UL	VTZ171-215	Multipack	6
	7773108	Belt type crankcase heater, 75 W, 230 V, CE mark, UL		Multipack	6
	7973005	Belt type crankcase heater, 75 W, 230 V, CE mark, UL		Industry pack	50
	7773118	Belt type crankcase heater, 75 W, 400 V, CE mark, UL		Multipack	6
	120Z0464	Belt type crankcase heater, 75 W, 460 V, CE mark, UL		Multipack	6

PTC heaters

Type	Code n°	Description	Application	Packaging	Pack size
PTC27W	120Z0459	PTC heater 27W	All models	Multipack	10
PTC27W	120Z0460	PTC heater 27W	All models	Industry pack	50

Lubricant , acoustic hoods and spareparts
Acoustic hoods

Code n°	Description	Application	Packaging	Pack size
120Z0575	Acoustic hood for 1 cyl	VTZ038-054	Single pack	1
120Z0576	Acoustic hood for 2 cyl	VTZ086-121	Single pack	1
7755202	Acoustic hood for 2 cyl (UL Approved)	VTZ086-121	Single pack	1
120Z0577	Acoustic hood for 4 cyl	VTZ171-215	Single pack	1

Mounting kits

Code n°	Description	Application	Packaging	Pack size
8156001	Mounting kit 1 & 2 cyl; Ebox: 80 x 96 mm; Sleeves 5/8" - 1/2"	VTZ038-054-086-121	Single pack	1
8156007	Mounting kit for 4 cylinder compressor & MS, including 4 grommets, 4 bolts Ebox: 96 x 115 mm; Sleeves 1"1/8 - 3/4"	VTZ171-215	Single pack	1

Terminal boxes, covers & T-block connectors

Code n°	Description	Application	Packaging	Pack size
8173230	T-block connector 52 x 57 mm, 3 screws H10-32 UNF9.5	All VTZ models	Multipack	10
120Z0149	Electrical box cover + clamp	All VTZ models	Single pack	1

Lubricants / oils

Type	Code n°	Description	Application	Packaging	Pack size
160PZ	7754019	POE lubricant, 160PZ, 1 litre can	VTZ with R404A, R507A, R134a, R407C	Multipack	12
160PZ	120Z0573	POE lubricant, 160PZ, 2.5 litre can	VTZ with R404A, R507A, R134a, R407C	Multipack	4

Miscellaneous

Type	Code n°	Description	Application	Packaging	Pack size
	8156145	Oil sight glass gasket (black)	All VTZ models	Multipack	10
	8156019	Oil sight glass + gaskets	All VTZ models	Multipack	4
	8154001	Blue spray paint	All VTZ models	Single pack	1

Spare parts Frequency converter
LCP's

Code n°	Description	Application	Packaging	Pack size
130B1107	LCP	Frequency converter / all models	Single pack	1
175Z0929	RS cable to LCP	Frequency converter / all models	Single pack	1
130B1088	LCP Blind cover	Frequency converter IP20/IP21	Single pack	1
130B1077	LCP Blind cover	Frequency converter IP55/IP66	Single pack	1

Control card

Code n°	Description	Application	Packaging	Pack size
130B1109	Control card	Frequency converter / all models	Single pack	1

Relays card

Code n°	Description	Application	Packaging	Pack size
130B1110	Relays card	Frequency converter	Single pack	1

Converters

Code n°	Description	Application	Packaging	Pack size
192L0929	RS232/RS485 Converter	Frequency converter	Single pack	1
192L0930	USB/RS485 Converter	Frequency converter	Single pack	1

Previous Version

- Page 14: Pressure equipment Directive **97/23/EC**, Low voltage directive **2006/95/EC**, Machine directive **2006/42/EC**, Internal free volume
- Page 15: VTZ121 Performance data
- Page 49: Acoustic hoods

Current Version

- Page 14: Updated Pressure equipment directive **2014/68/EU**, Low voltage directive **2014/35/EU**, Machine directive **2014/30/EU**. Added High side to Internal free volume
- Page 15: Updated VTZ121 (Max rpm) Performance data
- Page 49: Updated Code numbers in Acoustic hoods accessories

Danfoss Commercial Compressors

is a worldwide manufacturer of compressors and condensing units for refrigeration and HVAC applications. With a wide range of high quality and innovative products we help your company to find the best possible energy efficient solution that respects the environment and reduces total life cycle costs.

We have 40 years of experience within the development of hermetic compressors which has brought us amongst the global leaders in our business, and positioned us as distinct variable speed technology specialists. Today we operate from engineering and manufacturing facilities spanning across three continents.



Danfoss Scrolls



Danfoss Inverter Scrolls



Danfoss Turbocor Compressors



Danfoss Light Commercial Refrigeration Compressors



Danfoss Maneurop Reciprocating Compressors



Danfoss Optyma Condensing Units

Our products can be found in a variety of applications such as rooftops, chillers, residential air conditioners, heatpumps, coldrooms, supermarkets, milk tank cooling and industrial cooling processes.

<http://cc.danfoss.com>

Danfoss Commercial Compressors, BP 331, 01603 Trévoux Cedex, France | +334 74 00 28 29



Danfoss can accept no responsibility for possible errors in catalogues, brochures and other printed material. Danfoss reserves the right to alter its products without notice. This also applies to products already on order provided that such alterations can be made without subsequential changes being necessary in specifications already agreed. All trademarks in this material are property of the respective companies. Danfoss and the Danfoss logotype are trademarks of Danfoss A/S. All rights reserved.