

ENGINEERING
TOMORROW

Danfoss

Application Guide

Scroll Compressors VZH088-117-170 Gen3

Single, R410A



www.danfoss.com

Contents

Safety and warnings	5
Introduction	5
Product description	5
Cut Away VZH	5
Product identification	6
Name Plate	6
Nomenclature	6
Compressors serial number	7
Certificates, declarations and approvals	7
Pressure equipment directive 2014/68/EU	8
Low voltage directive 2014/35/EU	8
Internal free volume	8
Refrigerants	8
General Information	8
R410A	8
Technical specification	8
Compressor size	8
Compressor specification	9
Sound and vibration Data	9
Sound and vibration data	9
Sound level and acoustic hood	9
Operating envelope data	10
Operating envelope	10
Dimensions	11
VZH088-G/H single version (with oil sight glass)	11
VZH088-G/H unified version (with oil sight glass and oil level sensor)	12
VZH088-J single version (with oil sight glass)	13
VZH088 -J unified version (with oil sight glass and oil level sensor)	14
VZH117-G/H single version (with oil sight glass)	15
VZH117-G/H unified version (with oil sight glass and oil level sensor)	16
VZH117-J single version (with oil sight glass)	17

VZH117-J unified version (with oil sight glass and oil level sensor)	18
VZH170-G/H single version (with oil sight glass)	19
VZH170-G/H unified version (with oil sight glass and oil level sensor)	20
VZH170-J single version (with oil sight glass)	21
VZH170-J unified version (with oil sight glass and oil level sensor)	22
Mechanical connections	22
Connection Details	22
Design compressor mounting	24
System design generalities	25
Electrical connections	26
Wiring connections	26
Electrical specifications	28
Frequency converter	30
Product identification	30
Technical specification	30
Dimensions	31
Electrical connections	33
Drive installation	34
Troubleshooting	38
Compressor and drive control	41
Application Guideline	45
Manage Operating envelope	45
Manage sound and vibration	52
Oil return management	53
Manage Superheat	60
Manage off cycle migration	65
Assembly line procedure	69
Commissioning	72
Dismantle and disposal	73
Packaging	74
Single pack	74
Industrial pack	74
Frequency converter single pack	74
Ordering	75
Single pack	75

Industrial pack	75
Coils	75
VZH voltage code G - 380-480 Volt	75
VZH voltage code H - 525-600 Volt	76
VZH voltage code J - 200-240 Volt	76
Accessories and Spare parts	76
Solder sleeve adapter sets - Valves, adapters, connectors & gaskets for use on suction and discharge connections	76
Surface sump heaters	76
Discharge thermostats and sensors	77
Acoustic hoods - Lubricant, acoustic hoods and spare parts	77
Oil sight glass	77
Mounting kits	77
Terminal boxes, covers & T-block connectors	77
Coil	78
Valve Body	78
Lubricant / oils	78
Oil level switch	78
LCP's Spare parts frequency converter	78
Fans	78
Control card	78
Accessory bags	78
Relays card	78
Brackets	79
Online support	80

Safety and warnings

Danfoss scroll compressors are designed and manufactured with state of the art technology and follow European and US regulations. There is an added emphasis placed on safety and reliability. Critical instructions are highlighted with the following icons:

This icon indicates instructions to avoid safety risk.

This icon indicates instructions to avoid reliability risk.

The purpose of this guideline is informational, with the intent to educate customers as to how the compressors should properly function. If you need any additional assistance, please contact Danfoss Technical Support. In any case, Danfoss manufacturing accepts no liability as a result of misuse or improper integration of the compressor unit.

Introduction

Product description

Danfoss scroll compressor VZH for R410A is available as single compressor and can be assembled in hybrid tandem combination. VZH Gen3 scroll compressor benefit from an improved design to achieve the highest efficiency and increased life time.

Cut Away VZH

Figure 1: Cut Away VZH

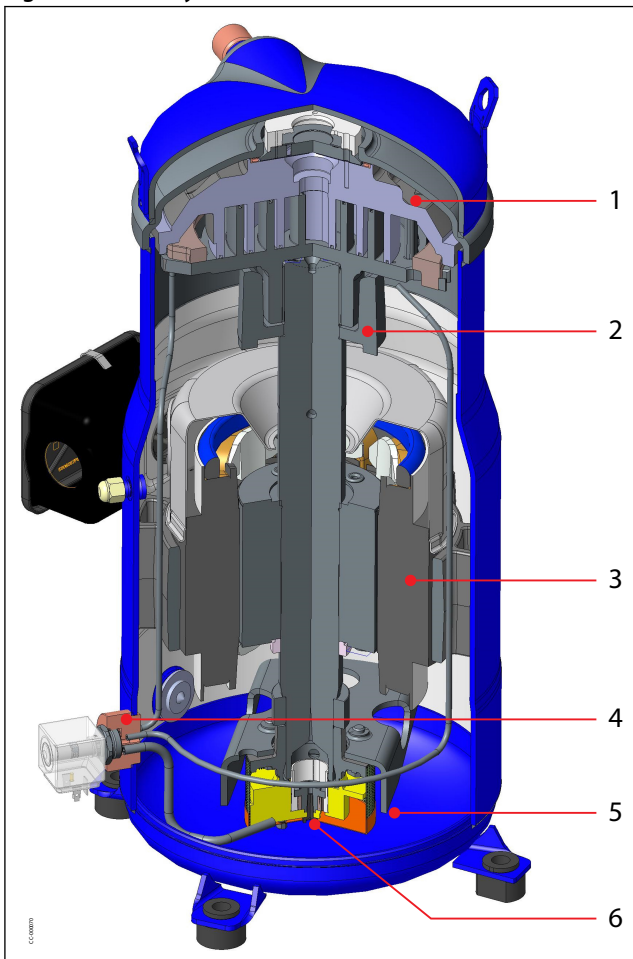

- | | |
|----------|---|
| 1 | Intermediate discharge valves (IDVs) increase part load efficiency |
| 2 | Lead free polymer bearing with excellent performance under diverse loads and speeds |
| 3 | Permanent magnet motor with high efficiency at all speeds |
| 4 | Patented oil injection control system: <ul style="list-style-type: none"> • Ensures optimal efficiency at low speed by improving scroll set sealing. • Optimizes the oil circulation. |
| 5 | Oil strainer controls the risk of system debris in the oil injection circuit |
| 6 | Gearotor oil pump ensures low speed bearing lubrication |

Product identification

Name Plate

Figure 2: Name Plate

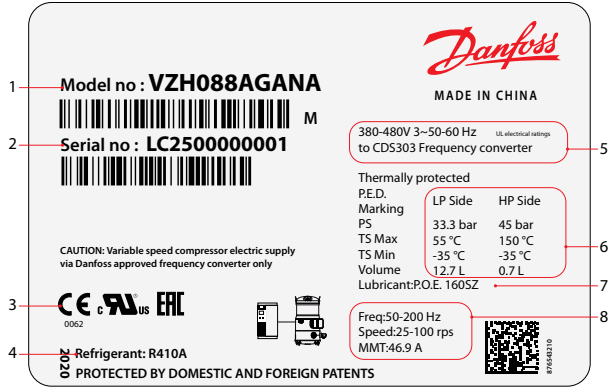

1	Model number
2	Serial number
3	Approvals and Certificates
4	Refrigerant
5	Supply voltage to CDS303 frequency converter
6	Housing service pressure
7	Factory charged lubricant
8	Compressor frequency & Max Must trip current

Nomenclature

Compressor nomenclature

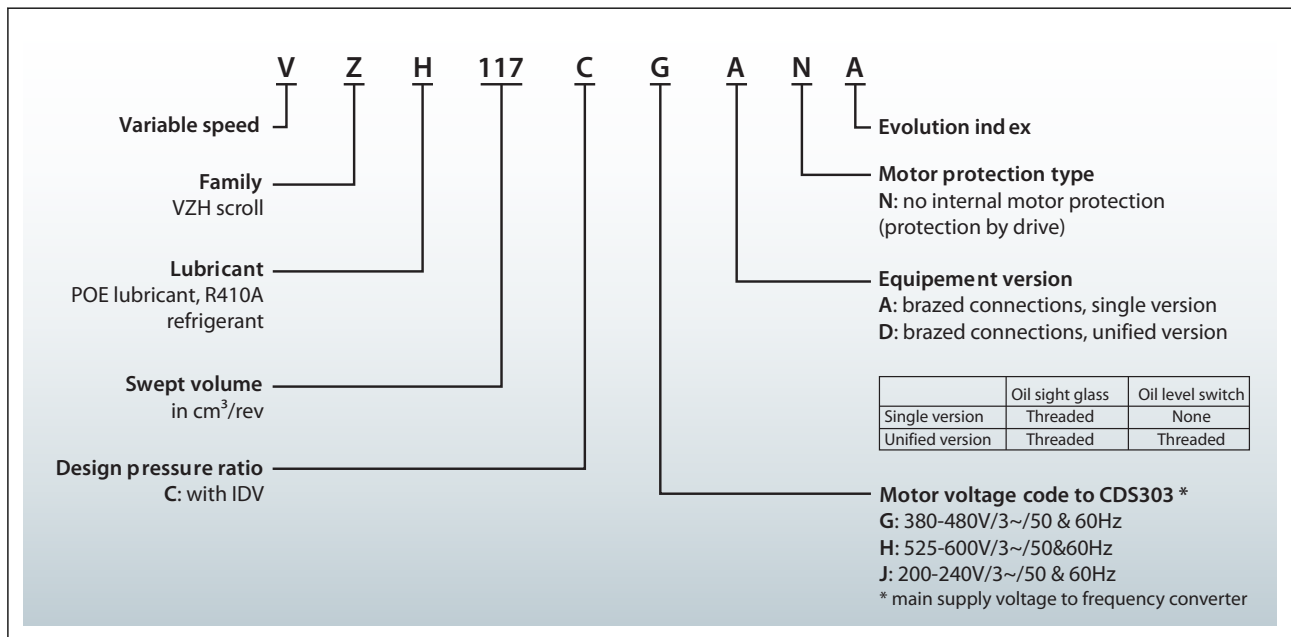

Compressors serial number

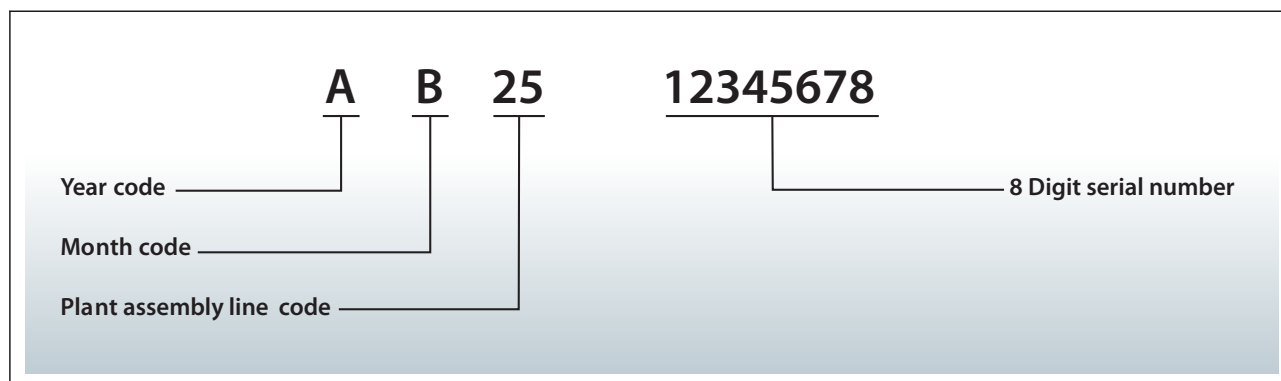

Table 1: Serial number code legend table

Year code		Month code		Plant assembly line code	
Year	Code	Month	Code	Plant	Code
1990, 2010	A	January	A	Trévoux, France	11
1991, 2011	B	February	B		
1992, 2012	C	March	C		
1993, 2013	D	April	D	Wuqing, China	25
1994, 2014	E	May	E		
1995, 2015	F	June	F		
1996, 2016	G	July	G		
1997, 2017	H	August	H		
1998, 2018	J	September	J		
1999, 2019	K	October	K		
2000, 2020	L	November	L		
2001, 2021	M	December	M		
2002, 2022	N				
2003, 2023	P				
2004, 2024	Q				
2005, 2025	R				
2006, 2026	S				
2007, 2027	T				
2008, 2028	U				
2009, 2029	V				

Certificates, declarations and approvals

VZH scroll compressors comply with the following approvals and certificates. Certificate are listed on:

[Documentation for Commercial Compressor | Danfoss](#)

Table 2: Certificates, declarations and approvals

Certificates, declarations and approvals	Certification logo	Models
CE (European Directive)		All VZH models
UL (Underwriters Laboratories)		All VZH models
EMC 2014/30/EU		All VZH models

Pressure equipment directive 2014/68/EU

Table 3: Pressure equipment directive 2014/68/EU

Products	VZH088	VZH117	VZH170
Fluids	Group 2	Group 2	Group 2
Category PED	II	II	II
Evaluation module	D1	D1	D1
TS - service temperature LP	-35°C < TS < +55°C -31°F < TS < 131°F	-35°C < TS < +55°C -31°F < TS < 131°F	-35°C < TS < +51°C -31°F < TS < 123.8°F
PS - service pressure LP	33.3 bar(g) 483 psi(g)	33.3 bar(g) 483 psi(g)	30.2 bar(g) 438 psi(g)

Low voltage directive 2014/35/EU

Table 4: Low voltage directive 2014/35/EU

Products	VZH088-117-170
Declaration of conformity ref. Low voltage Directive 2014/35/EU	Contact Danfoss

Internal free volume

Table 5: Internal free volume

Products	Internal free volume at LP side without oil	
	litre	cu.inch
VZH088	12.7	775
VZH117	15.1	921
VZH170	29.9	1825

Refrigerants

General Information

When choosing a refrigerant, different aspects must be taken into consideration:

- Legislation (now and in the future)
- Safety
- Application envelope in relation to expected running conditions
- Compressor capacity and efficiency
- Compressor manufacturer recommendations & Guidelines

Additional points could influence the final choice:

- Environmental considerations
- Standardisation of refrigerants and lubricants
- Refrigerant cost
- Refrigerant availability

R410A

R410A is a HFC blend (R32: 50%; R125: 50%) with a zero Ozone Depletion Potential (ODP=0) and a Global Warming Potential of 1924/AR5 (2088/AR4). It is a near-azeotropic mixture with a temperature glide less than 0.2 K.

With its high net refrigeration effect coupled to a high density, the R410A has appeared in last decade to be the preferred refrigerant for use in commercial air conditioners and heat pumps.

Technical specification

Compressor size

Compressor can be sized on peak load, for best applied cost, or optimal efficiency. For optimal efficiency, see our performance details in Coolselector software.



For regular updates and detailed capacities, please refer to [Coolselector®2](#).

Compressor specification

Table 6: Compressor specification

Compressor model	Swept volume		Displacement								Oil charge		Net weight	
			25 rps		50 rps		60 rps		100 rps					
	cm ³ /rev	cu.in/rev	m ³ /h	cu.ft/h	m ³ /h	cu.ft/h	m ³ /h	cu.ft/h	m ³ /h	cu.ft/h	dm ³	oz	kg	lbs
VZH088	88.4	5.39	7.96	281	15.91	562	19.09	675	31.82	1125	3.8	128	55	121
VZH117	116.9	7.13	10.52	372	21.04	744	25.25	892	42.08	1487	4.1	139	61	134
VZH170	170.2	10.38	15.32	541	30.64	1083	36.76	1299	61.27	2165	7.7	260	112	247

Sound and vibration Data

Sound and vibration data

Typical sounds and vibrations in systems can be broken down into the following three categories:

- Sound radiation (through air)
- Mechanical vibrations (through parts and structure)
- Gas pulsation (through refrigerant)

The following sections focus on the causes and methods of mitigation for each of the above sources.

Sound level and acoustic hood

Table 7: Sound level and acoustic hood

Model	Frequency RPS	200V		400V		575V	
		Without acoustic hood (dBA)	Acoustic hood code	Without acoustic hood (dBA)	Acoustic hood code	Without acoustic hood (dBA)	Acoustic hood code
VZH088	30	71	120Z0510 ⁽¹⁾ 120Z0512 ⁽²⁾	71	120Z0509 ⁽¹⁾ 120Z0511 ⁽²⁾	72	120Z0509 ⁽¹⁾ 120Z0511 ⁽²⁾
VZH088	60	79		80		80	
VZH088	90	89		88		88	
VZH117	30	73	120Z0514 ⁽¹⁾ 120Z0516 ⁽²⁾	72	120Z0513 ⁽¹⁾ 120Z0515 ⁽²⁾	71	120Z0513 ⁽¹⁾ 120Z0515 ⁽²⁾
VZH117	60	83		82		82	
VZH117	90	93		90		91	
VZH170	30	78	120Z0519 ⁽¹⁾ 120Z0520 ⁽²⁾	77	120Z0517 ⁽¹⁾ 120Z0518 ⁽²⁾	79	120Z0517 ⁽¹⁾ 120Z0518 ⁽²⁾
VZH170	60	89		87		88	
VZH170	90	95		94		94	

⁽¹⁾ single version

⁽²⁾ unified version

NOTE:

- Average sound power for reference at ARI A/C (7.2 °C/54.4 °C/11.1 °C/8.3 °C) (45 °F/130 °F/20 °F/15 °F) conditions measured in free space.
- Acoustic can decrease 5~7dBA

Operating envelope data

Operating envelope

Figure 3: VZH088/117 C Operating Map - R410A

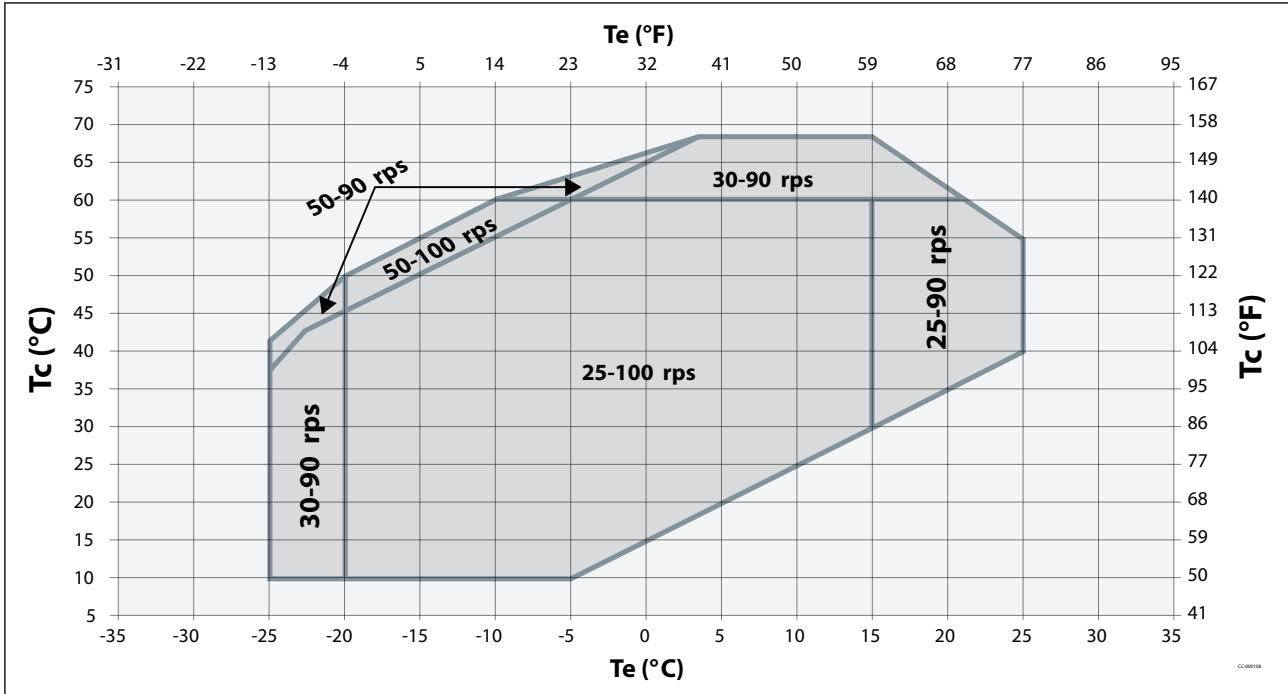
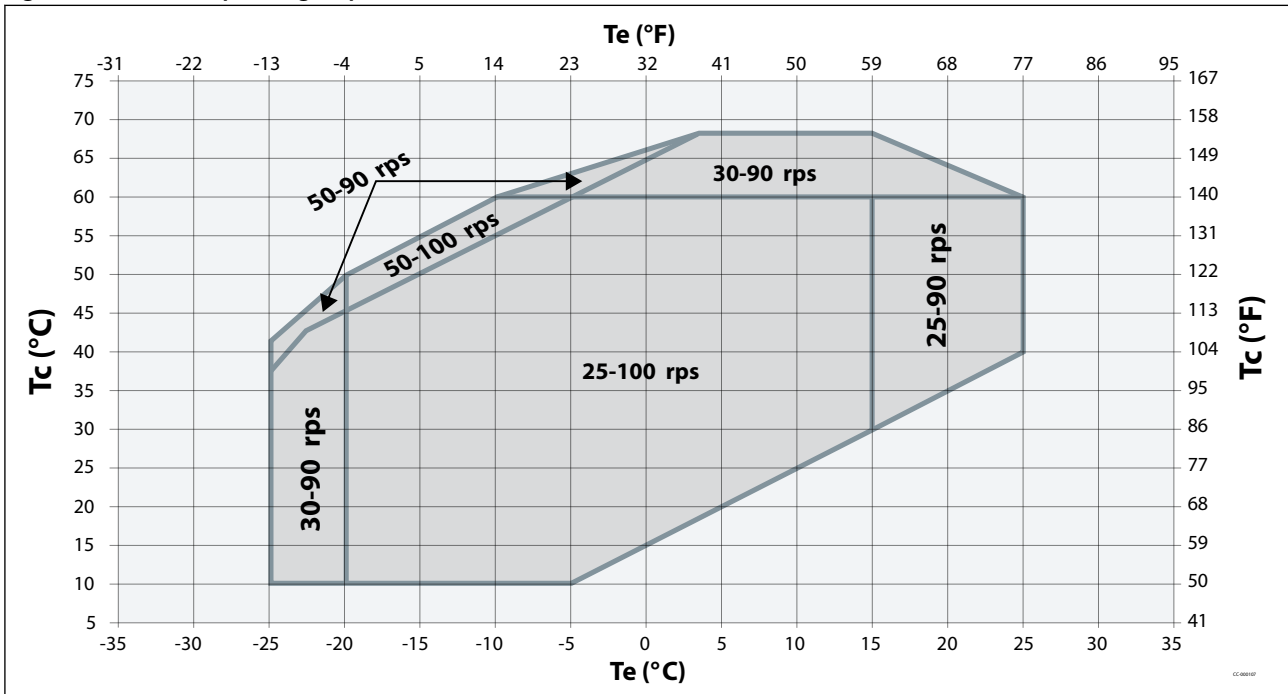

Figure 4: VZH170 C Operating Map - R410A



NOTE:

The solid line envelope is valid for a suction superheat within 5K at nominal voltage. Higher suction superheat may lead to discharge temperatures above 135°C (275°F);

For superheat between 5K and 11K, this top left envelope might be reduced by condensing temperature of 1°C or 2°C in order to keep discharge T° below 135°C (275°F).

For superheat above 11K, the envelop will further be reduced based on 135°C discharge temperature restriction.

Pressure settings

Table 8: Pressure settings for R410A

Pressure settings	bar (g)	psi (g)
Working pressure range low side	2.3~15.7	33.36~227.7
Maximum high pressure safety switch setting	46.1	668.62
Minimum low pressure safety switch setting	1.5	21.75
Recommended pump-down switch settings	1.5 bar below nominal evaporating pressure	21 psi below nominal evaporating pressure
Pump down cut-out pressure	2.3	33

Dimensions

VZH088-G/H single version (with oil sight glass)

Figure 5: Outline drawing number 1

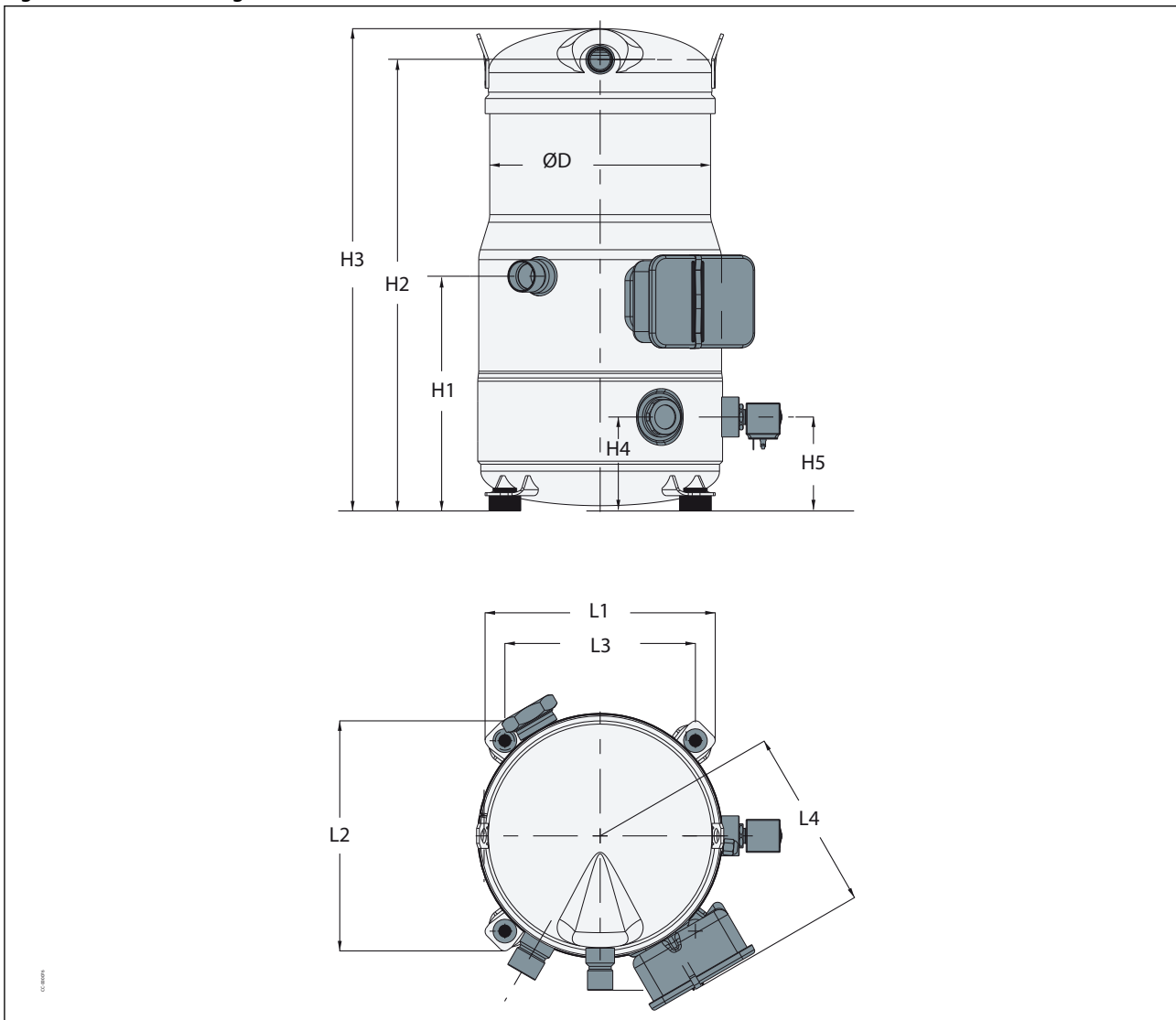

Table 9: Dimensions for VZH088-G/H single version

Compressor model	D		H1		H2		H3		H4		H5		L1		L2		L3		L4		Outline drawing number
	mm	in	mm	in	mm	in	mm	in	mm	in	mm	in	mm	in	mm	in	mm	in	mm	in	
VZH088-G/H	220.8	8.69	234.6	9.23	451.2	17.76	484.8	19.08	93.8	3.69	93.8	3.69	230	9.05	230	9.05	190.5	7.5	180.7	7.11	8560025

Also refer [Grommets](#) and [Wiring connections](#)

VZH088-G/H unified version (with oil sight glass and oil level sensor)

Figure 6: Outline drawing number 2

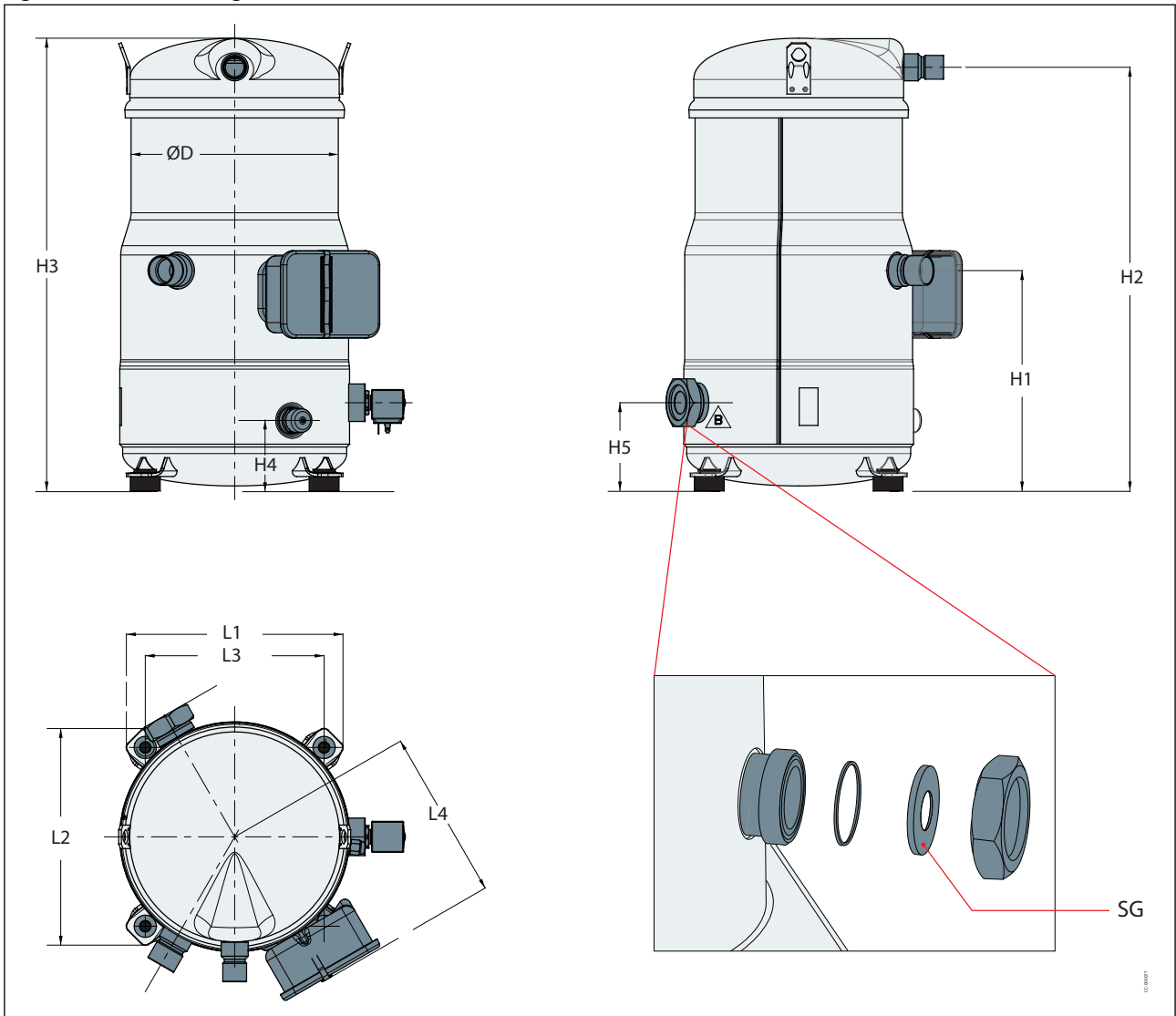

SG Sight glass

Table 10: Dimensions for VZH088-G/H Unified version

Compressor model	D		H1		H2		H3		H4		H5		L1		L2		L3		L4		Outline drawing number
	mm	in	mm	in	mm	in	mm	in	mm	in	mm	in	mm	in	mm	in	mm	in	mm	in	
VZH088-G/H	220.8	8.69	234.6	9.23	451.2	17.76	484.8	19.08	74.8	2.94	93.8	3.69	230	9.05	230	9.05	190.5	7.5	180.7	7.11	8560097

Also refer [Grommets](#) and [Wiring connections](#)

VZH088-J single version (with oil sight glass)

Figure 7: Outline drawing number 3

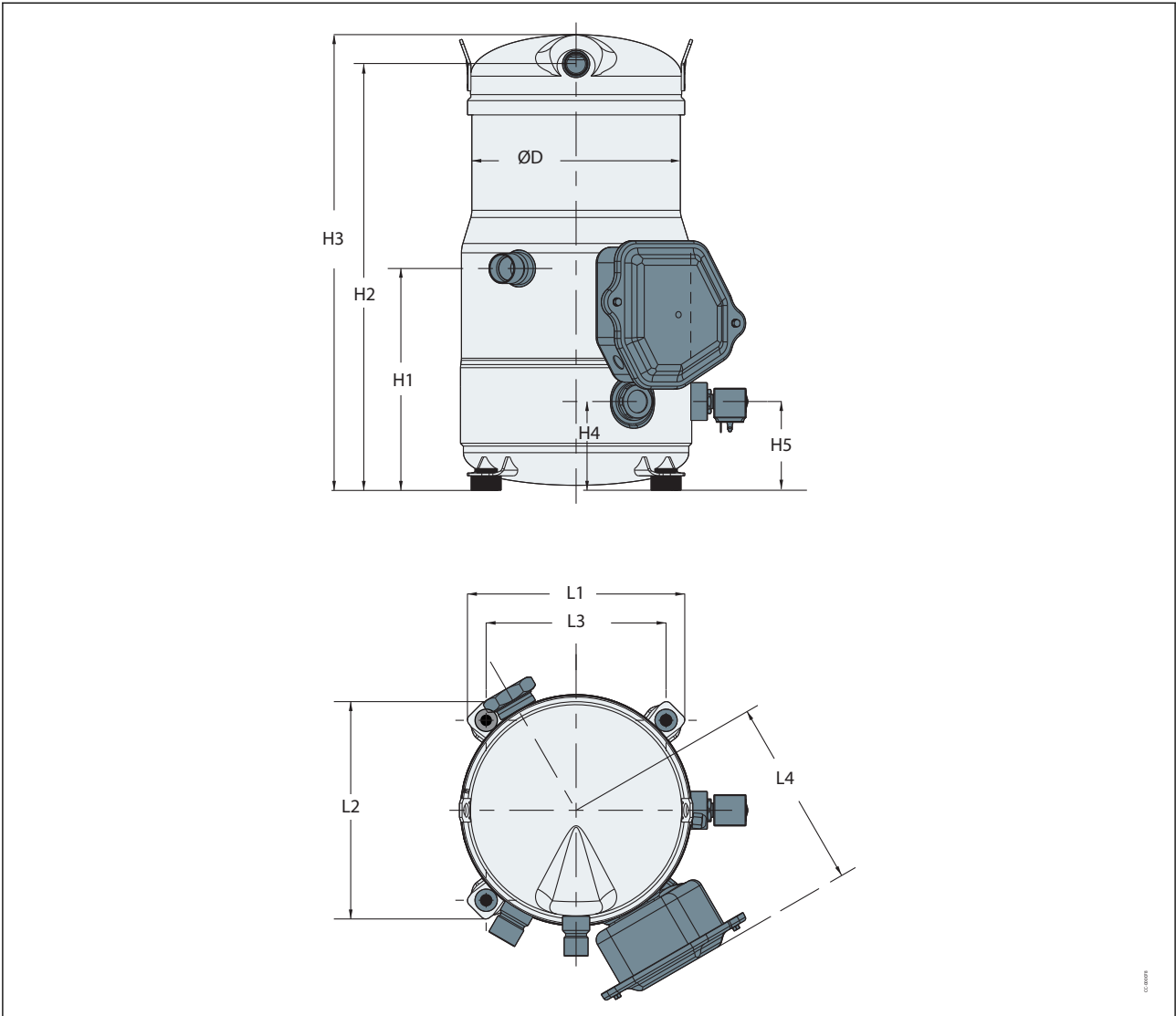

Table 11: Dimensions for VZH088-J single version

Compressor model	D		H1		H2		H3		H4		H5		L1		L2		L3		L4		Outline drawing number
	mm	in	mm	in	mm	in	mm	in	mm	in	mm	in	mm	in	mm	in	mm	in	mm	in	
VZH088-J	220.8	8.69	234.6	9.23	451.2	17.76	484.8	19.08	93.8	3.69	93.8	3.69	230	9.05	230	9.05	190.5	7.5	200.4	7.81	8560030

Also refer [Grommets](#) and [Wiring connections](#)

VZH088 -J unified version (with oil sight glass and oil level sensor)

Figure 8: Outline drawing number 4

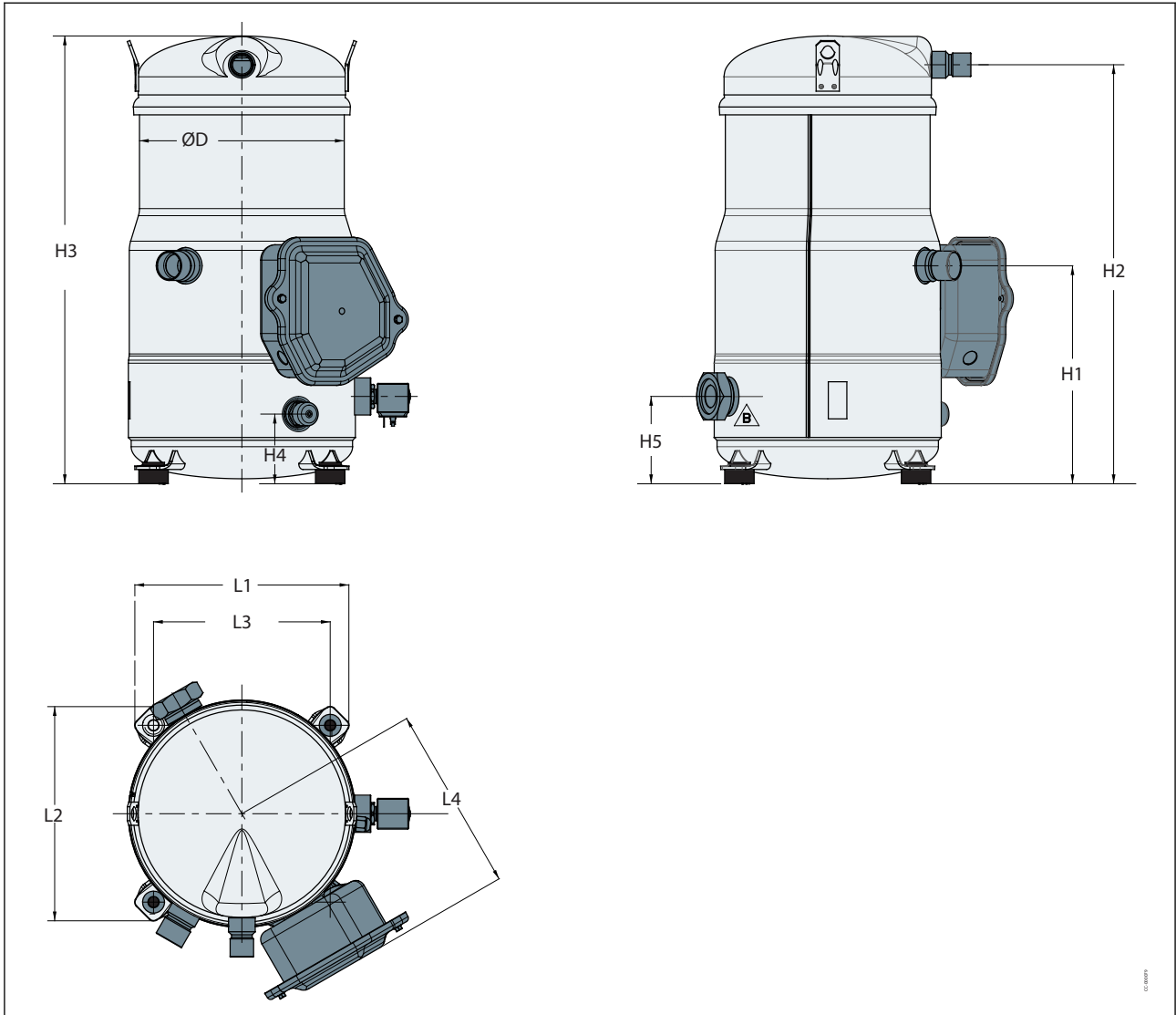

Table 12: Dimensions for VZH088-J Unified version

Compressor model	D		H1		H2		H3		H4		H5		L1		L2		L3		L4		Outline drawing number
	mm	in	mm	in	mm	in	mm	in	mm	in	mm	in	mm	in	mm	in	mm	in	mm	in	
VZH088-J	220.8	8.69	234.6	9.23	451.2	17.76	484.8	19.08	74.8	2.94	93.8	3.69	230	9.05	230	9.05	190.5	7.5	200.4	7.81	8560098

Also refer [Grommets](#) and [Wiring connections](#)

VZH117-G/H single version (with oil sight glass)

Figure 9: Outline drawing number 5

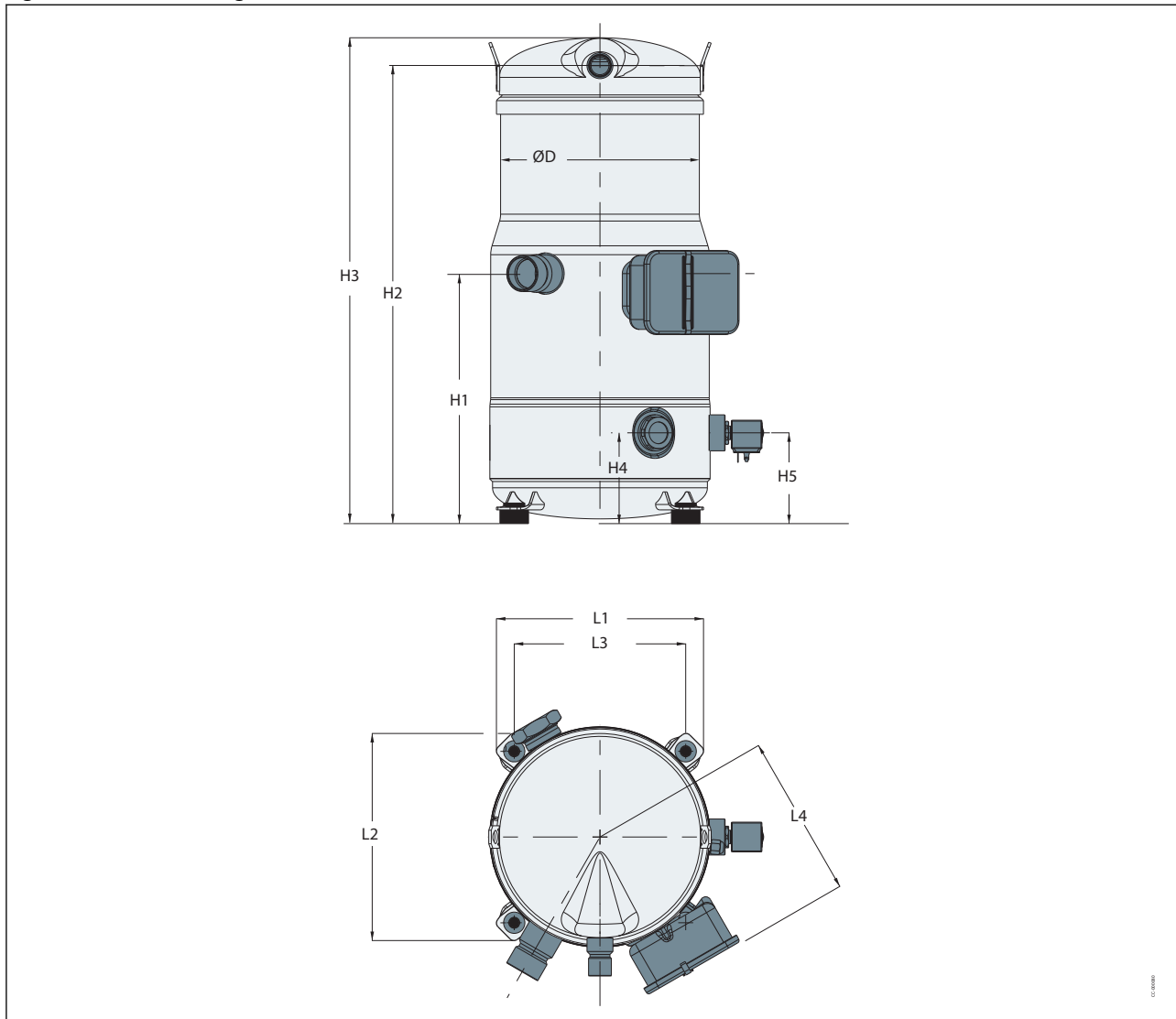

Table 13: Dimensions for VZH117-G/H single version

Compressor model	D		H1		H2		H3		H4		H5		L1		L2		L3		L4		Outline drawing number
	mm	in	mm	in	mm	in	mm	in	mm	in	mm	in	mm	in	mm	in	mm	in	mm	in	
VZH117-G/H	220.8	8.69	276.9	10.92	507.9	20.02	541.6	21.34	100	3.96	100	3.96	230	9.05	230	9.05	190.5	7.5	180.7	7.11	8560026

Also refer [Grommets](#) and [Wiring connections](#)

VZH117-G/H unified version (with oil sight glass and oil level sensor)

Figure 10: Outline drawing number 6

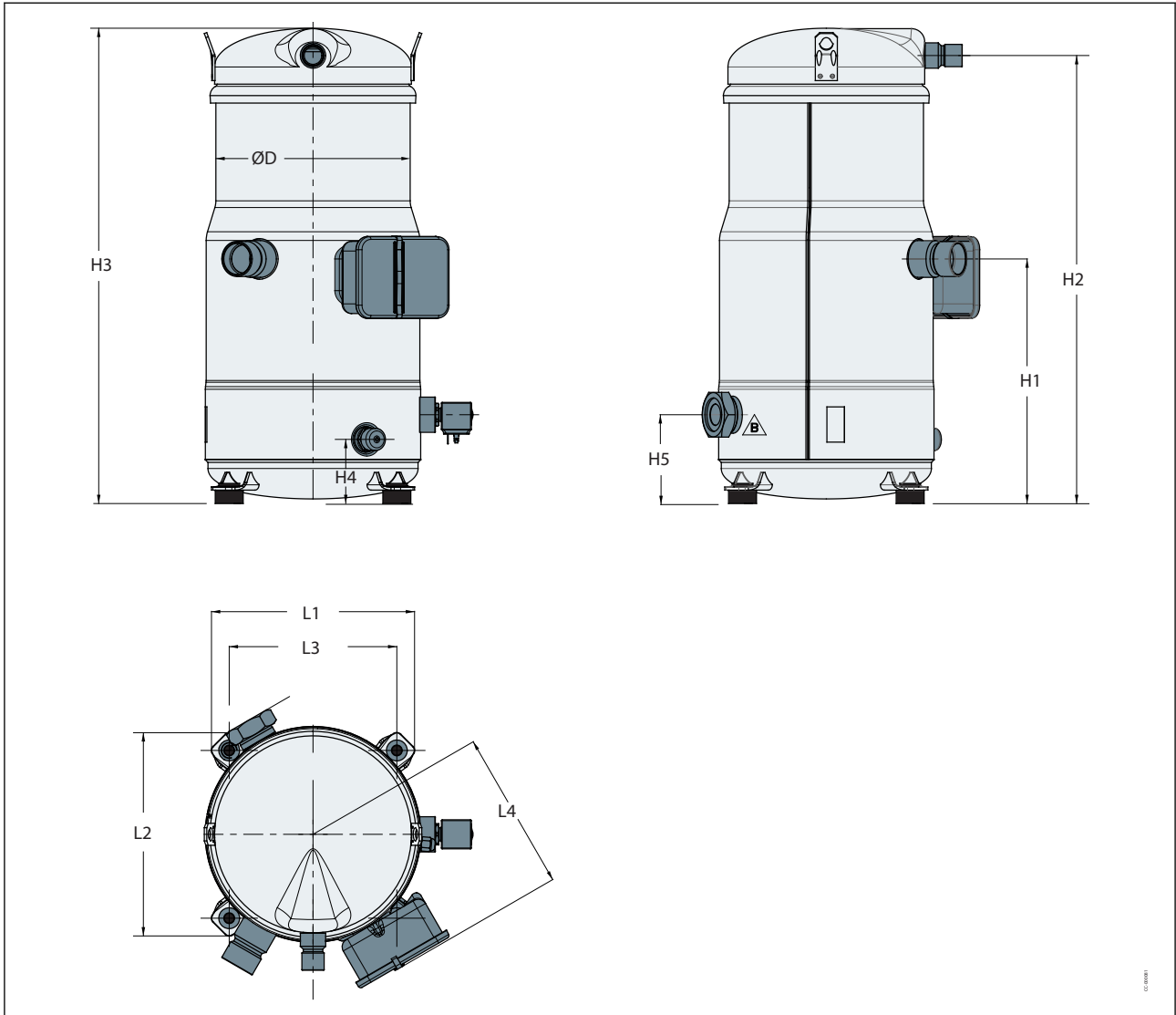

Table 14: Dimensions for VZH177-G/H unified version

Compressor model	D		H1		H2		H3		H4		H5		L1		L2		L3		L4		Outline drawing number
	mm	in	mm	in	mm	in	mm	in	mm	in	mm	in	mm	in	mm	in	mm	in	mm	in	
VZH117-G/H	220.8	8.69	276.9	10.92	507.9	20.02	541.6	21.34	72	2.86	100	3.96	230	9.05	230	9.05	190.5	7.5	180.7	7.11	8560099

Also refer [Grommets](#) and [Wiring connections](#)

VZH117-J single version (with oil sight glass)

Figure 11: Outline drawing number 7

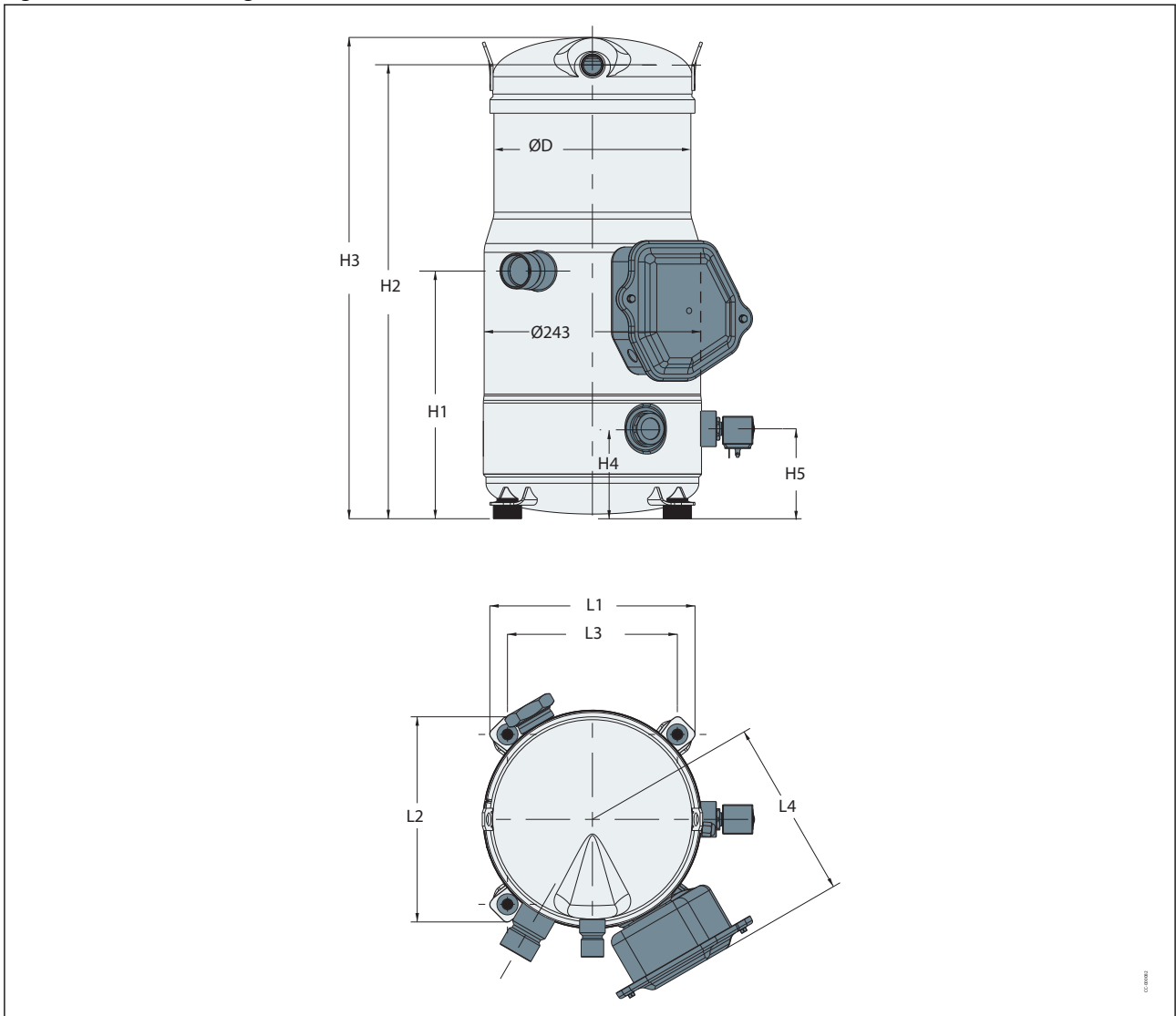

Table 15: Dimensions for VZH117-J single version

Compressor model	D		H1		H2		H3		H4		H5		L1		L2		L3		L4		Outline drawing number
	mm	in	mm	in	mm	in	mm	in	mm	in	mm	in	mm	in	mm	in	mm	in	mm	in	
VZH117-J	220.8	8.69	276.9	10.92	507.9	20.02	541.6	21.34	100	3.96	100	3.96	230	9.05	230	9.05	190.5	7.5	200.4	7.87	8560031

Also refer [Grommets](#) and [Wiring connections](#)

VZH117-J unified version (with oil sight glass and oil level sensor)

Figure 12: Outline drawing number 8

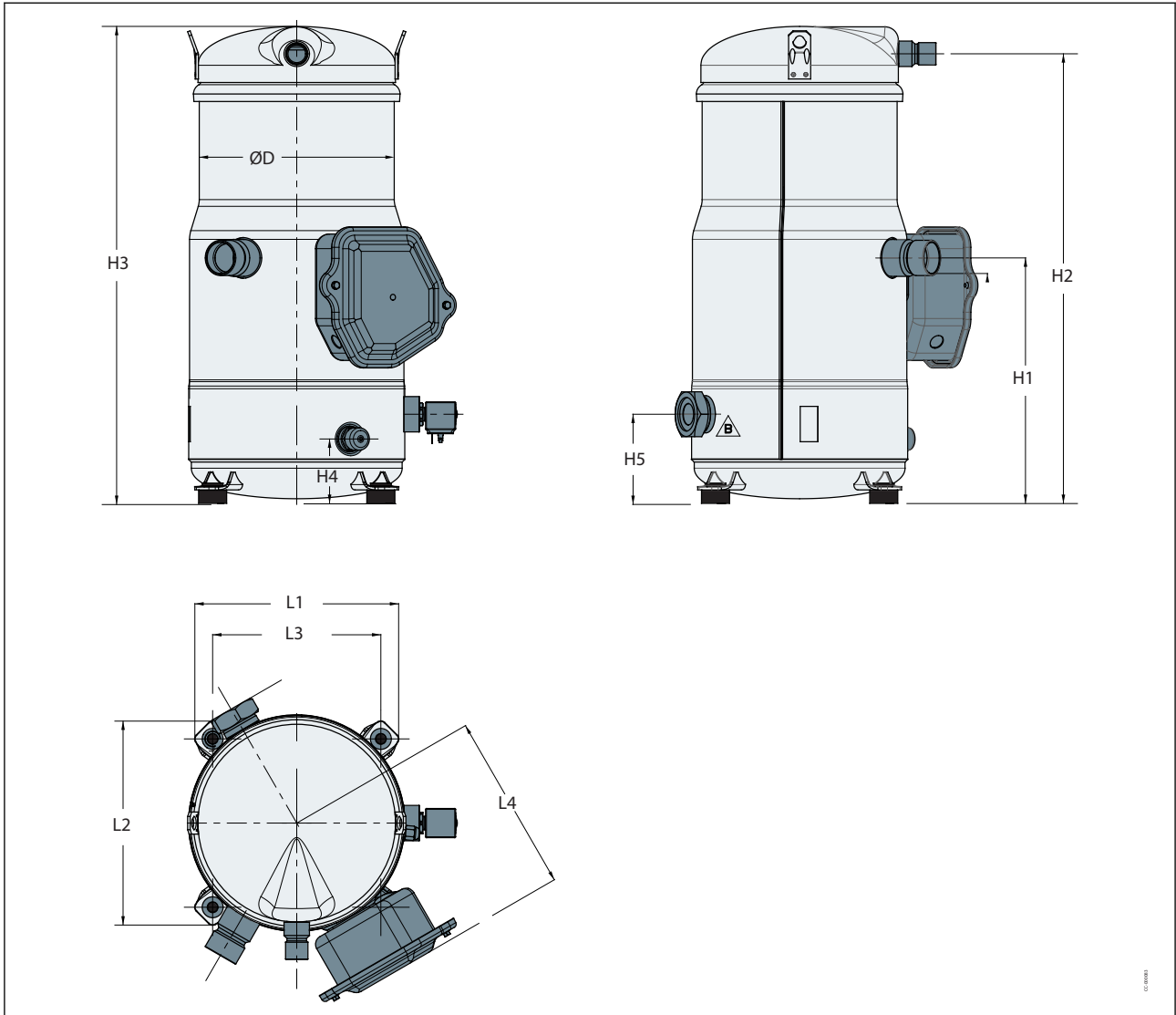

Table 16: Dimensions for VZH117-J unified version

Compressor model	D		H1		H2		H3		H4		H5		L1		L2		L3		L4		Outline drawing number
	mm	in	mm	in	mm	in	mm	in	mm	in	mm	in	mm	in	mm	in	mm	in	mm	in	
VZH117-J	220.8	8.69	276.9	10.92	507.9	20.02	541.6	21.34	72	2.86	100	3.96	230	9.05	230	9.05	190.5	7.5	200.4	7.87	8560100

Also refer [Grommets](#) and [Wiring connections](#)

VZH170-G/H single version (with oil sight glass)

Figure 13: Outline drawing number 9

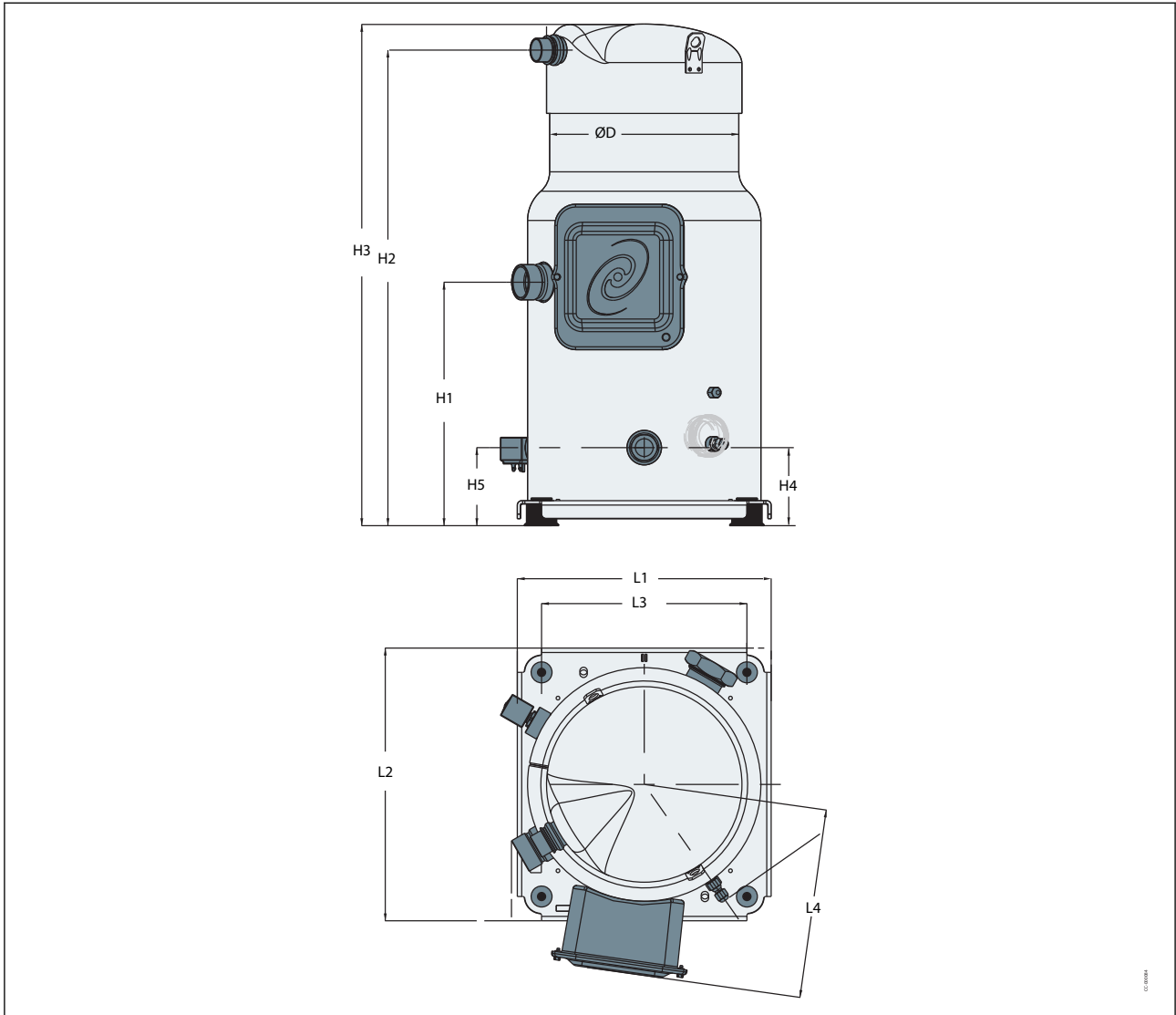

Table 17: Dimensions for VZH170-G/H single version

Compressor model	D		H1		H2		H3		H4		H5		L1		L2		L3		L4		Outline drawing number
	mm	in	mm	in	mm	in	mm	in	mm	in	mm	in	mm	in	mm	in	mm	in	mm	in	
VZH170-G/H	257	10.12	329	12.97	644.5	25.39	686.5	27.04	104.1	4.10	104.1	4.10	345	13.58	371	14.61	279.4	11	257	10.12	8551186

Also refer [Grommets](#) and [Wiring connections](#)

VZH170-G/H unified version (with oil sight glass and oil level sensor)

Figure 14: Outline drawing number 10

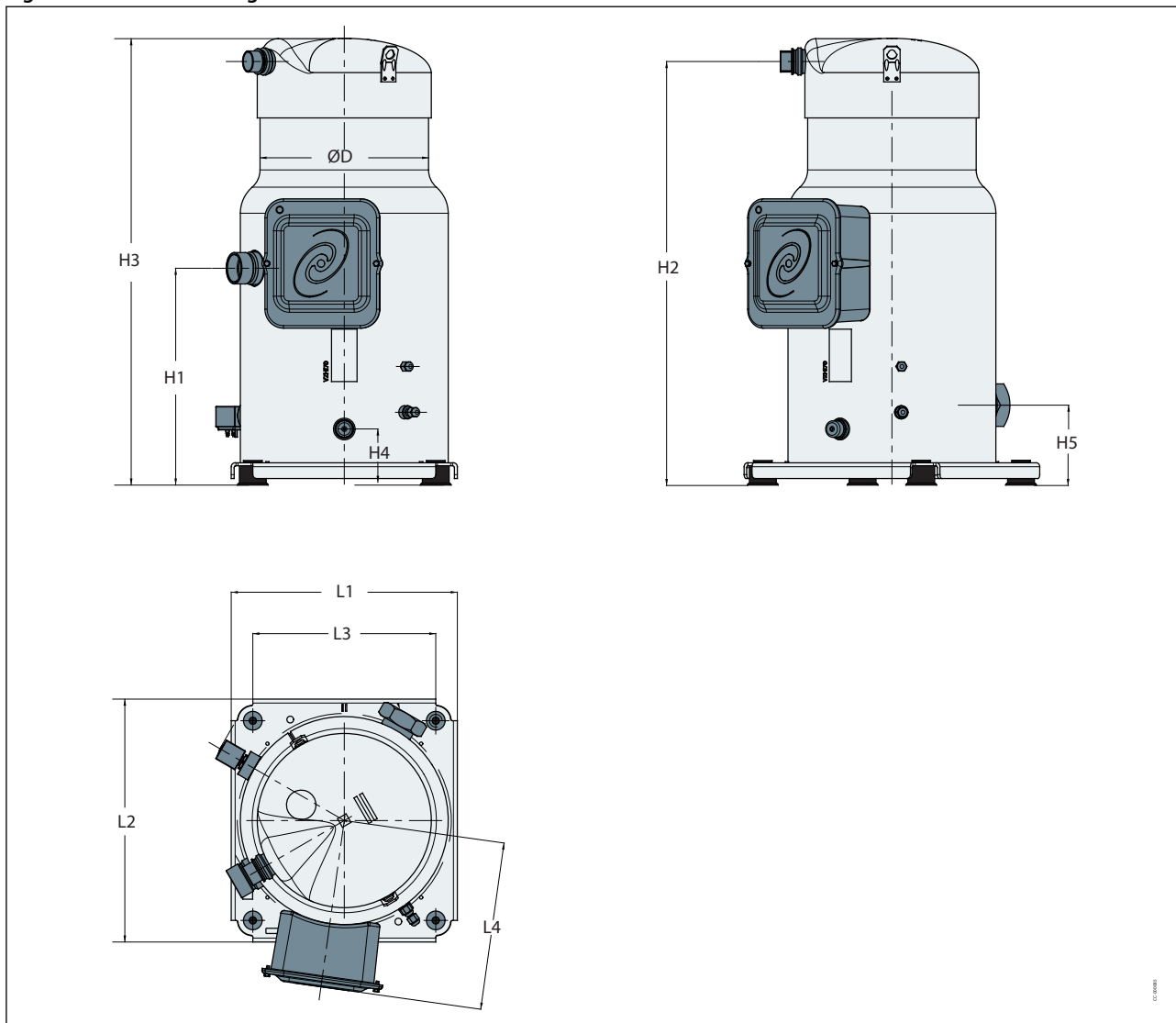

Table 18: Dimensions for VZH170-G/H unified version

Compressor model	D		H1		H2		H3		H4		H5		L1		L2		L3		L4		Outline drawing number
	mm	in	mm	in	mm	in	mm	in	mm	in	mm	in	mm	in	mm	in	mm	in	mm	in	
VZH170-G/H	257	10.12	329	12.97	644.5	25.39	686.5	27.04	83.6	3.3	120.5	4.74	345	13.58	371	14.61	279.4	11	257	10.12	8560095

Also refer [Grommets](#) and [Wiring connections](#)

VZH170-J single version (with oil sight glass)

Figure 15: Outline drawing number 11

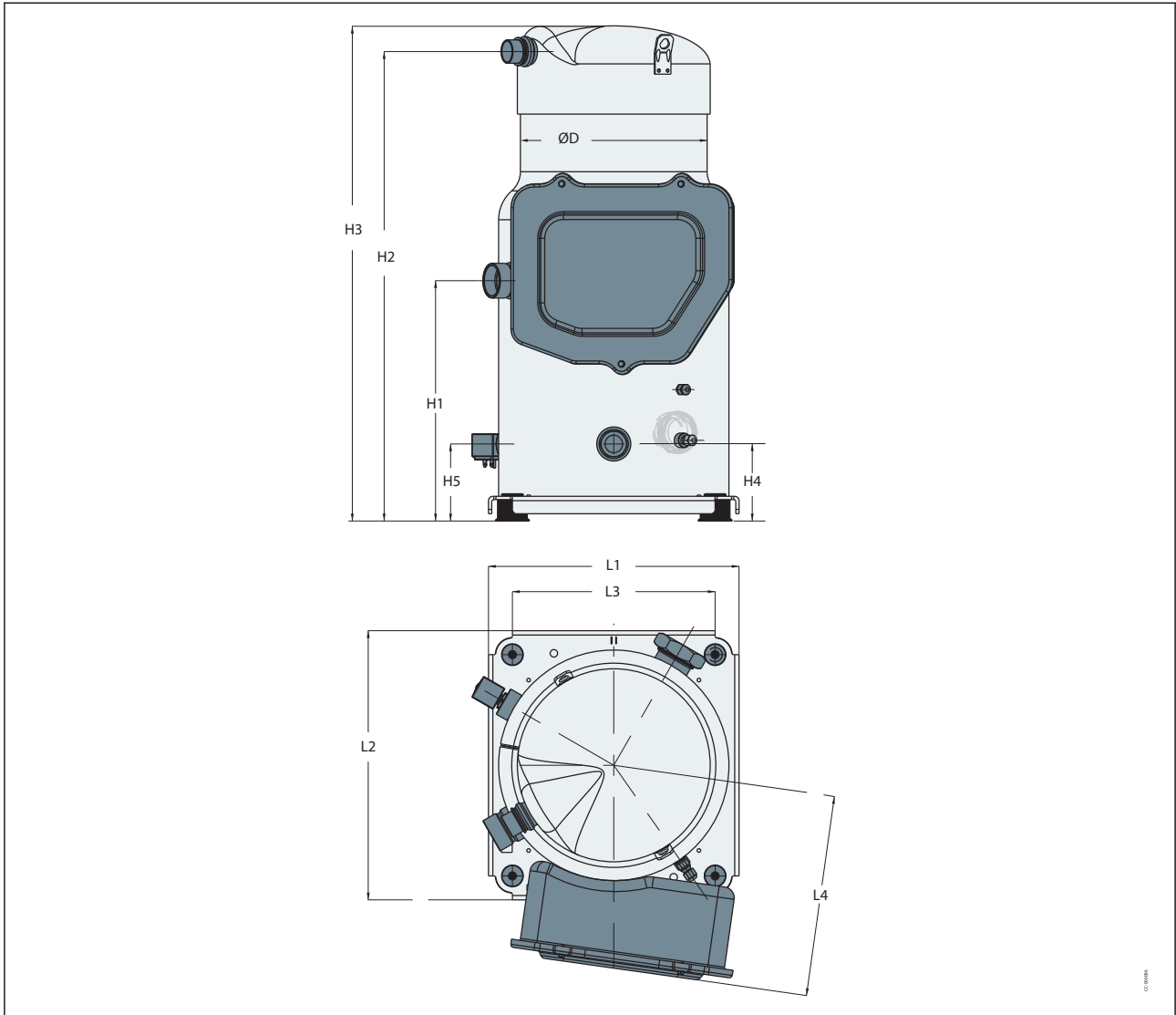

Table 19: Dimensions for VZH170-J single version

Compressor model	D		H1		H2		H3		H4		H5		L1		L2		L3		L4		Outline drawing number
	mm	in	mm	in	mm	in	mm	in	mm	in	mm	in	mm	in	mm	in	mm	in	mm	in	
VZH170-J	257	10.12	329	12.97	644.5	25.39	686.5	27.04	104.1	4.10	104.1	4.10	345	13.58	371	14.61	279.4	11	257	10.12	8551174

Also refer [Grommets](#) and [Wiring connections](#)

VZH170-J unified version (with oil sight glass and oil level sensor)

Figure 16: Outline drawing number 12

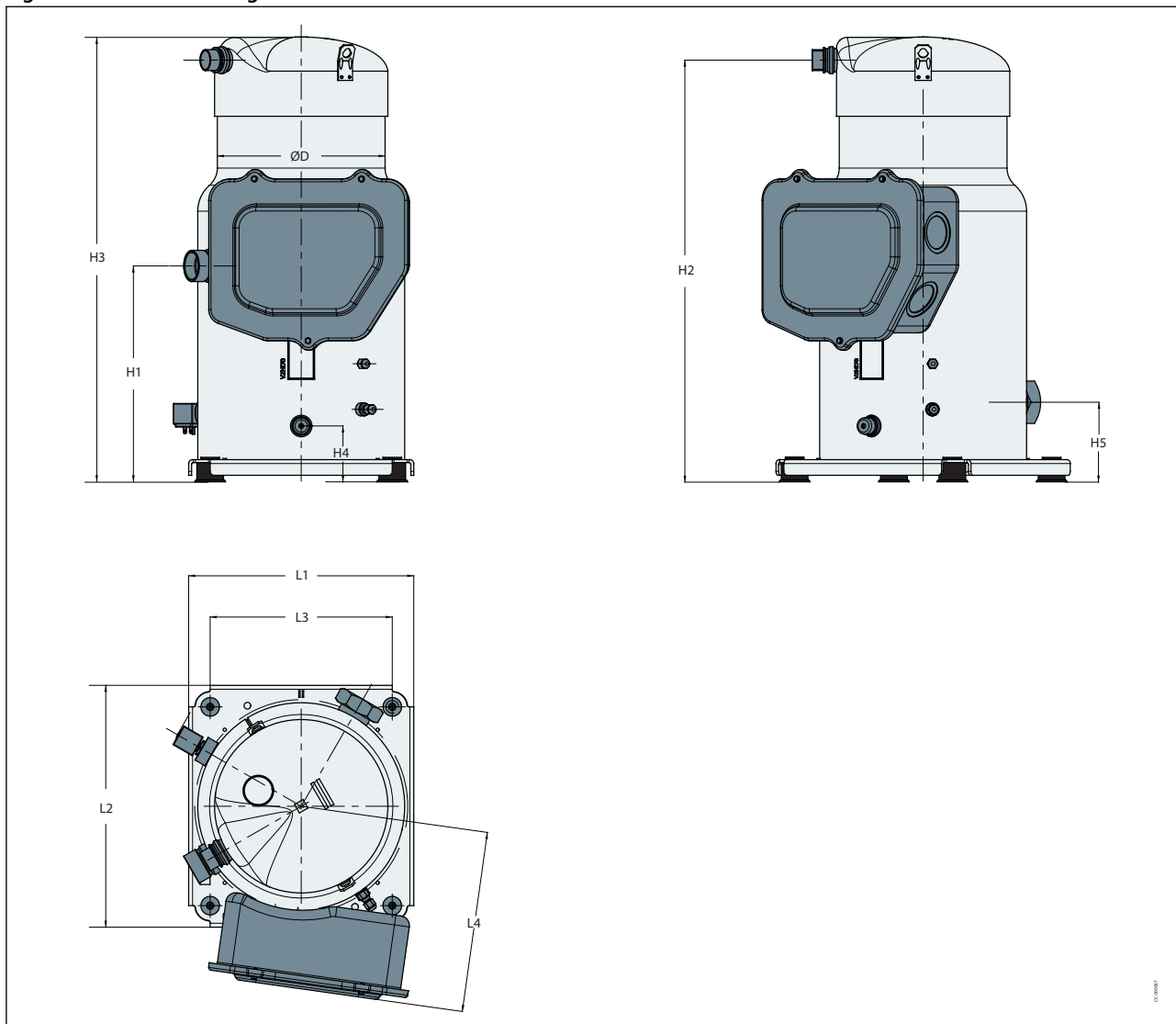

Table 20: Dimensions for VZH170-J unified version

Compressor model	D		H1		H2		H3		H4		H5		L1		L2		L3		L4		Outline drawing number
	mm	in	mm	in	mm	in	mm	in	mm	in	mm	in	mm	in	mm	in	mm	in	mm	in	
VZH170-J	257	10.12	329	12.97	644.5	25.39	686.5	27.04	83.6	3.3	120.5	4.74	345	13.58	371	14.61	279.4	11	257	10.12	8560096

Also refer [Grommets](#) and [Wiring connections](#)

Mechanical connections

Connection Details

Table 21: Connection Details

Connection Details		VZH088		VZH117		VZH170	
		Single	Unified	Single	Unified	Single	Unified
Suction connection		1"1/8	1"1/8	1"3/8	1"3/8	1"5/8	1"5/8
Discharge connection		7/8"	7/8"	7/8"	7/8"	1"1/8	1"1/8
Oil sight glass		Threaded (1"1/8 – 18 UNF)	on oil equalization port	Threaded (1"1/8 – 18 UNF)	on oil equalization port	Threaded (1"1/8 – 18 UNF)	on oil equalization port

Scroll Compressors, VZH088-117-170 Gen3 | Mechanical connections





Connection Details	VZH088		VZH117		VZH170	
	Single	Unified	Single	Unified	Single	Unified
Oil level sensor 	None	Threaded M20x1.5	None	Threaded M20x1.5	None	Threaded M20x1.5
Oil equalization connection 	Rotolock 1"3/4	Rotolock 1"3/4	Rotolock 1"3/4	Rotolock 1"3/4	Rotolock 2"1/4	Rotolock 2"1/4
Oil drain connection 	Female 1/4" Flare incorporating a Schrader valve					
Low pressure gauge port (Schrader) 	Male 1/4" Flare incorporating a Schrader valve					
Outline	1	2	1	2	3	4

Figure 17: Outline drawing 1

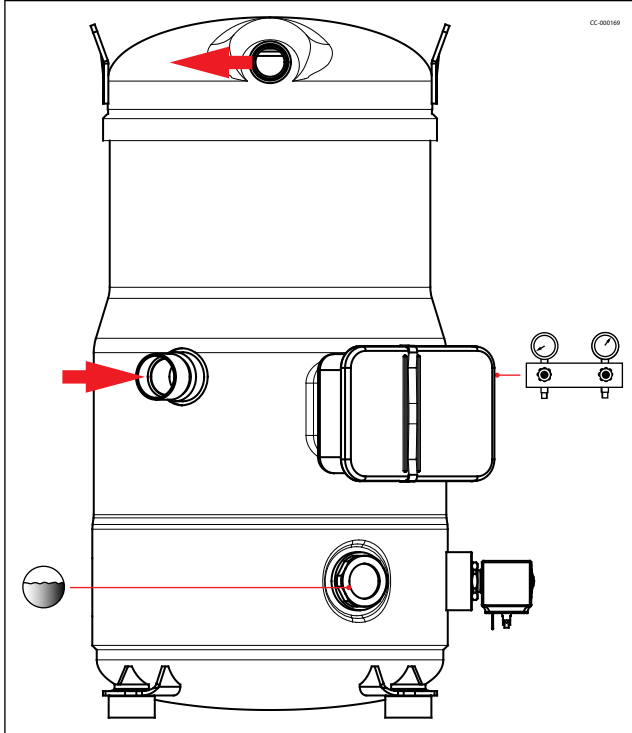

Figure 18: Outline drawing 2

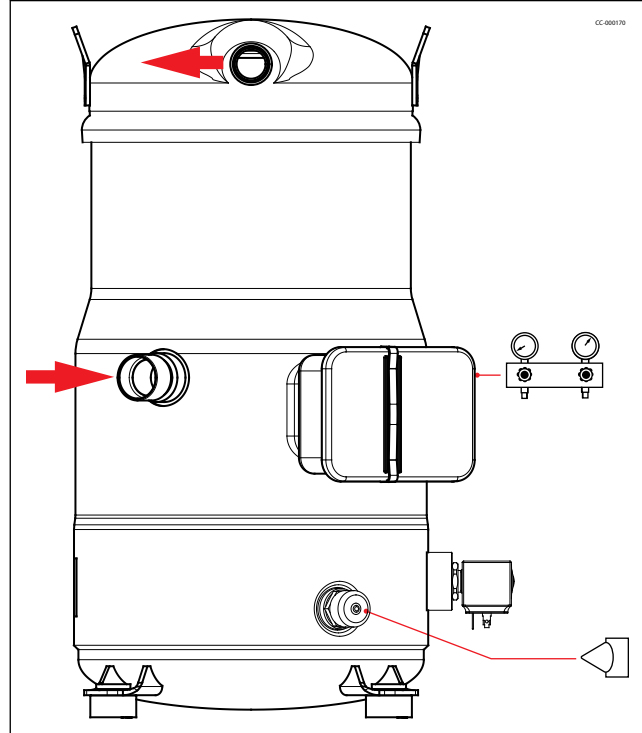

Figure 19: Outline drawing 3

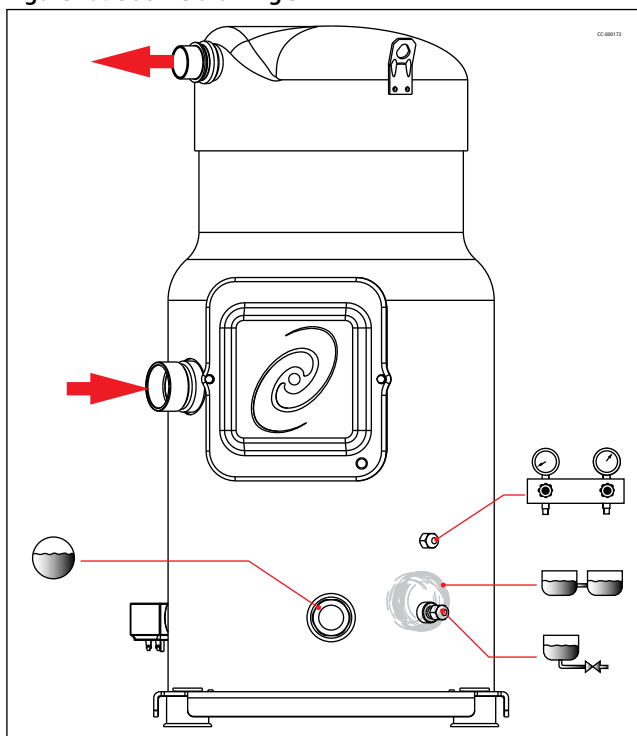

Figure 20: Outline drawing 4

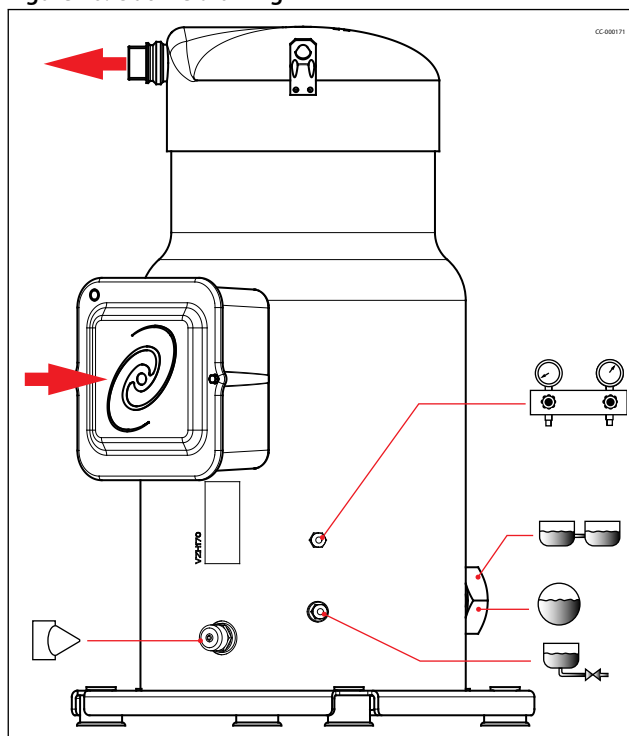

Table 22: Brazed connection

Compressor models	Brazed		Rotolock adaptor set ⁽¹⁾			Rotolock adaptor ⁽²⁾
	connection	size	Rotolock	Solder sleeve ODF	Code Number	Code Number
VZH088	Suction	1"1/8	1"3/4	1"1/8	120Z0125	120Z0364
VZH088	Discharge	7/8"	1"1/4	7/8"	120Z0125	120Z0367
VZH117	Suction	1"3/8	1"3/4	1"3/8	120Z0405	120Z0431
VZH117	Discharge	7/8"	1"1/4	7/8"	120Z0405	120Z0367
VZH170	Suction	1"5/8	2"1/4	1"5/8	7765028	120Z0432
VZH170	Discharge	1"1/8	1"3/4	1"1/8	7765028	120Z0364

⁽¹⁾ adaptor, gasket, sleeve, nut

⁽²⁾ adaptor only

VZH compressors are all delivered with suction and discharge brazed connections only. They are copper-plated steel connections.

Rotolock adaptors are available, refer to the information above.

Design compressor mounting

Grommets

Compressors used in single applications must be mounted with flexible grommets and metal sleeve delivered with compressor. The grommets attenuate the transmission of compressor vibrations to the base frame. The grommets must be compressed until contact between the flat washer and the steel mounting sleeve is established.

The required bolt size for the VZH088 & 117 compressors is HM8-40. This bolt must be tightened to a torque of 15 Nm (11 ft/lbs.).

The required bolt size for VZH170 compressors is HM8-55 and must be tightened to a torque of 21Nm (15 ft/lbs).

Figure 21: Grommets for VZH088 and VZH117

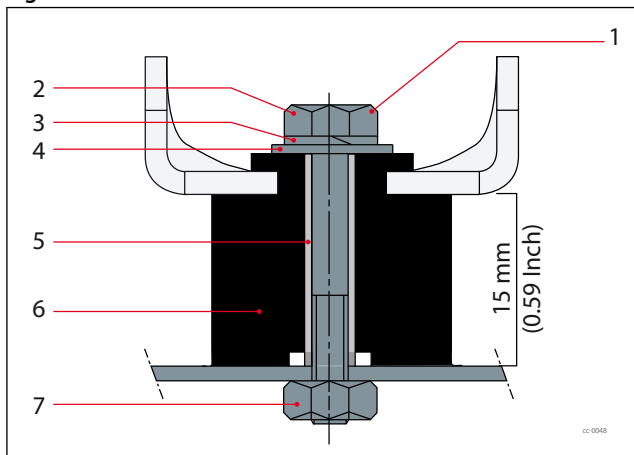

1	Tightening torque 15 Nm
2	HM 8 bolt
3	Lock washer
4	Flat washer
5	Steel mounting sleeve
6	Rubber grommet
7	Nut

Figure 22: Grommets for VZH170

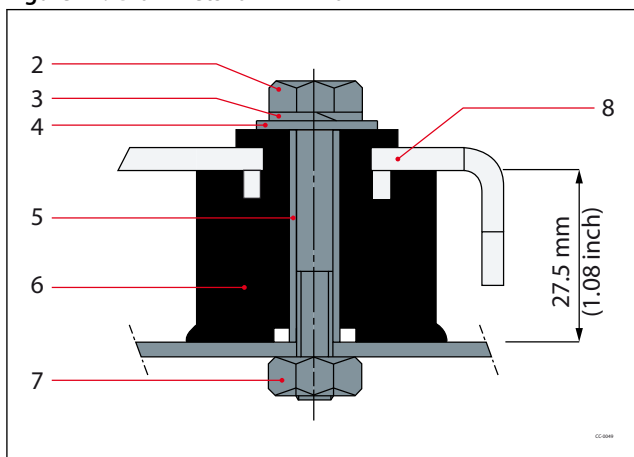

2	HM 8 bolt
3	Lock washer
4	Flat washer
5	Steel mounting sleeve
6	Rubber grommet
7	Nut
8	Compressor base plate

Max inclination

During operation, the maximum inclination from the vertical plane must not exceed 3 degrees.

System design generalities

Compressor capacity and modulation

R Usually, compressors are selected to cover peak load cooling/heating capacities between 70-100 rps.

Modulation (difference between minimum speed and maximum speed) is a very important point for unit design. The larger the modulation number, the challenging the unit design will be. This would consequently increase unit cost. For example, very low speed running may require the installation of an oil separator to guarantee oil return.

The minimum compressor speed must be defined according to unit need. It often makes sense to set unit minimum speed higher than minimum compressor speed qualified by Danfoss.

Differences between variable speed and fix in speed unit design

R Variable speed compressors were created with state of the art technology with the intent to be efficient and precise. Speed variations have led to challenges that must be addressed by unit design.

Variable speed compressor is a great technology to design efficient and precise unit, however, speed variation lead to challenges that must be addressed by unit design. The first challenge is linked to part of the load operation. Unit design must ensure that oil is returning back to the compressor, even while it is at the lowest speed. The expansion device must also ensure safe superheat across speed range. The second challenge is due to variation of speed itself.

On the opposite hand, on a variable speed system, compressor speed is permanently changing according to load. Compressor speed is permanently changing according to load. Consequently, expansion valve must adapt quickly enough to guaranty proper superheat control during transient.

Variation of compressor speed can also lend it's own challenges for vibrations. While in fix speed, only one frequency is excited by the compressor. In variable speed, the whole compressor frequency range may excite the system. The chance of going through resonant resonant frequency is then more greatly increased. The following chapters gives details advices to integrate variable speed compressor in a unit. Designing a variable speed unit requires to go through all of them to define necessary safeties and qualifications.

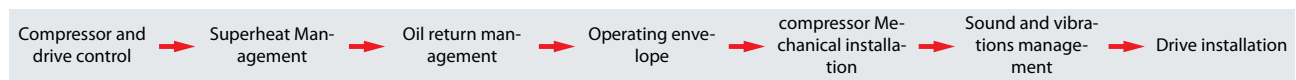

Electrical connections

Wiring connections

Electrical power is connected to the compressor terminals by #10-32 UNF 2A screws. The maximum thightening torque is 3 Nm. Use a 1/4" ring terminal on the power leads.

⚠ A cable gland, conduit connector or approved electrical fittings must be used on electrical box's knockouts to protect against accidental contact with electrical parts inside.

Motor protection

VZH scroll compressors are not equipped with an internal motor protector. Motor protection is provided by the variable speed drive. All parameters are factory preset in order to guaranty locked rotor or overload current protection.

When a warning situation is reached in the current control, the CDS frequency converter will automatically reduce the compressor speed in order to keep the motor current of the compressor below the maximum allowed.

VZH088/117-G/H

The terminal box is provided with a ϕ 33mm (ϕ 1.3 inch) hole (ISO32) for power supply.

Figure 23: Tirminal box for VZH088/117-G/H

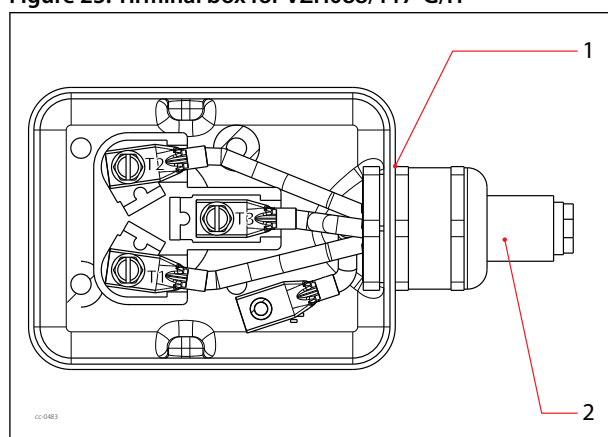

- | | |
|---|-------------------------------|
| 1 | ϕ 33 mm (1.30 inch) hole |
| 2 | Power supply |

VZH088/117-J

The terminal box is provided with a ϕ 40.5mm (ϕ 1.59 inch) hole (ISO40) for power supply and a ϕ 16.5mm (ϕ 0.65 inch) knockout (ISO16).

Figure 24: terminal box for VZH088/117-J

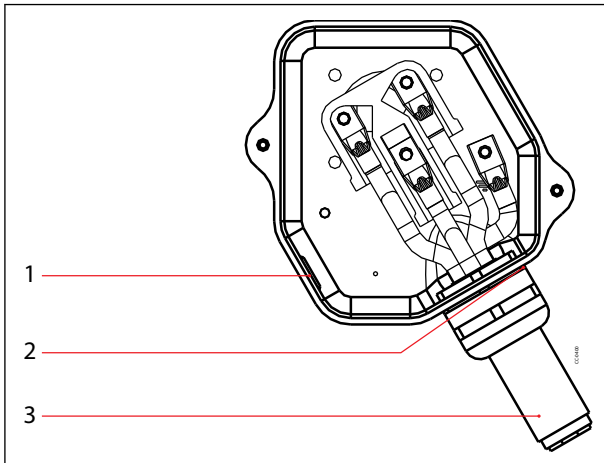

1	Ø 16.5mm (φ0.65inch) knockout
2	Ø 40.5mm (φ1.59inch) hole
3	Power supply

VZH170-G/H

φ 40.5mm (φ 1.59inch) (ISO 40) hole with possible φ 50.5mm (φ 1.98inch)(ISO50) knockout for power supply

Figure 25: terminal box for VZH170-G/H

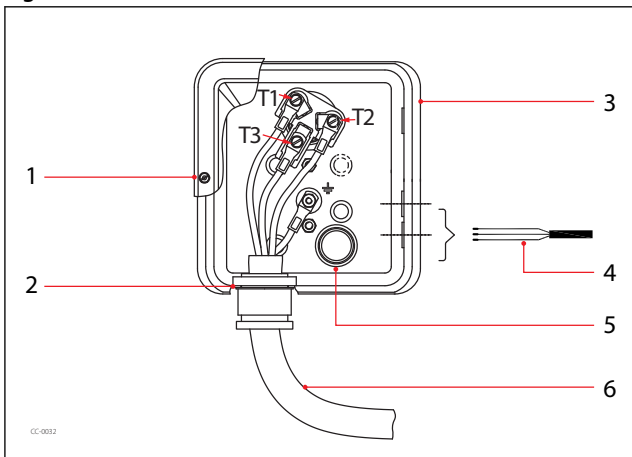

1	Cover holding screw (x2) - Torque: 2.2 Nm
2	Ø 40.5 mm (1.59 inch) hole Ø 50.5 mm (1.99 inch) knockout
3	Terminal box
4	Sump heater
5	Faston 1/4" tabs
6	Power supply

VZH170-J

φ 50.5mm (φ 1.98inch) (ISO 50 & UL1"1/2 conduit) hole with possible φ 63.5mm (φ 2.5inch) (ISO63 and UL 2"conduit) knockout for power supply.

2 x φ 22.5mm (φ 0.89inch) (PG16 and UL ." conduit) knockouts.

Figure 26: terminal box for VZH170-J

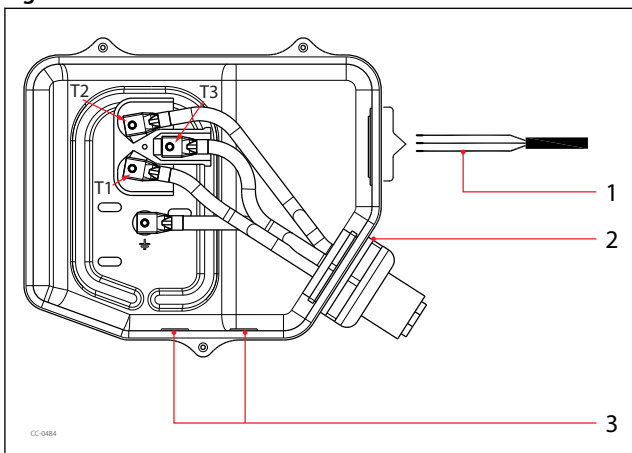

1	Sump heater
2	Ø 50.5 mm (1.99 inch) hole Ø 63.5 mm (2.50 inch) knockout
3	Ø 22.5 mm (0.89 inch) knockout

Electrical specifications

Supply voltage

Because VZH compressors are powered by a frequency converter, the mains frequency, 50 or 60 Hz, is no longer an issue. Only the mains voltage is to be taken into account. With 3 motor voltage codes, the most common mains voltages and frequencies are covered.

VZH all published data, Coolselector data and polynomials are based on 208V frequency converter power supply for code J and 400V for code G. When having a supply of 230V, 380V or 460V the following coefficients must be applied:

$$I_{460} = 0.87 * I_{400}$$

$$I_{380} = 1.05 * I_{400}$$

$$I_{230} = 0.90 * I_{208}$$

There is no modification for cooling capacity and power input.

Since data published for code H is based on 575V frequency converter supply, thus there will be no coefficients modification applied for H code.

Table 23: Mains voltage range of drive

Voltage code	Mains voltage range of drive
J	200-240V / 3ph / 50Hz & 60Hz (±10%)
G	380-480V / 3ph / 50Hz & 60Hz (±10%)
H	525-600V /3ph / 50Hz & 60Hz (±10%)

⚠ Never connect the VZH compressor directly to the mains power supply in case of frequency converter defect.

Voltage imbalance

The maximum allowable voltage imbalance between each phase is 3%. Voltage imbalance causes high amperage over one or several phases, which in turn leads to overheating and possible drive damage.

IP rating

The compressor terminal box IP rating according to CEI529 is IP54 when correctly sized IP54 rated cable glands are used.

Element	Numerals or letters	Meaning for the protection of equipment
First characteristic numeral Against ingress of solid foreign objects	0	(non protected)
	1	≥ 50 mm diameter
	2	≥ 12.6 mm diameter
	3	≥ 2.5 mm diameter
	4	≥ 1.0 mm diameter
	5	dust protected
Second characteristic numeral Against ingress of water with harmful effects	6	dust tight
	0	(non protected)
	1	vertically dripping
	2	dripping (15° tilted)
	3	spaying
	4	splashing
	5	jetting
	6	powerful jetting
7	temporary immersion	
8	continuous immersion	

Compressors 3 phases electrical characteristics

Table 24: Compressors 3 phases electrical characteristics

Volt	Compressor	RW ⁽¹⁾	RLA ⁽²⁾	MMT ⁽³⁾
		(Ohm)	(A)	(A)
200 - 240 Volt	VZH088-J	0.03	74.8	93.5
	VZH117-J	0.02	88.0	110.0
	VZH170-J	0.01	115.0	143.8
380 - 480 Volt	VZH088-G	0.10	37.5	46.9
	VZH117-G	0.08	44.0	55.0
	VZH170-G	0.05	61.0	76.3
525 - 600 Volt	VZH088-H	0.10	37.5	46.9
	VZH117-H	0.08	44.0	55.0
	VZH170-H	0.05	61.0	76.3

⁽¹⁾ Winding resistance per winding (in CDS303 parameter list)

⁽²⁾ Rated load current

⁽³⁾ Maximum must trip current

NOTE:

Parameter 1-30 in the frequency converter settings reflects the winding resistance per winding. This is not the same value as measured at the motor terminals.

RLA (Rated Load Amp)

Rated Load Amp value for variable speed compressor is the current value at maximum load, in the operating envelope, and at maximum speed and rated drive input voltage, it is different than fixed speed compressor (uses MCC/1.56 or 1.4).

RLA is the measured value at the compressor terminals (after the drive).

MMT (Maximum Must Trip current)

The Maximum Must Trip current is defined for compressors not equipped with their own motor protection. This MMT value is the maximum at which the compressor can be operated in transient conditions and out of the operating envelope. The tripping current of external overcurrent protection, in this case preprogrammed in the drive, never exceeds the MMT value.

For VZH compressors, MMT value is 125% of RLA. This value is printed on the compressor nameplate.

Phase sequence and reverse rotation protection

⚠ The compressor will only operate properly in a single direction. If electrical connections are done correctly between the drive and the compressor terminals (compressor T1/T2/T3 and drive terminals U, V & W matching), the drive will provide correct phase supply to the compressor, and reverse rotation will be not possible:

- CDS terminal U (96) to VZH terminal T1
- CDS terminal V (97) to VZH terminal T2
- CDS terminal W (98) to VZH terminal T3

If compressor T1/T2/T3 and drive U, V & W terminals are not matching, the compressor can operate in a reverse rotation. This results in excessive noise and no pressure differential between suction and discharge, and suction line warming rather than immediate cooling. (damage is in seconds, very little temp delta can be measured....no value to statement). The compressor can be rapidly damaged in these conditions. Reverse rotation of the compressor for only a few seconds can quickly cause irreversible damage to the scroll sets. Before starting always review the wiring and be prepared to shutoff immediately in case of noise. If reverse rotation symptoms occur, shut the compressor down and connect the phases to their proper terminals. Allow the compressor to run and then check amps at operating condition versus Danfoss published performance data to see if there was damage.

Frequency converter

Product identification

Frequency converter nomenclature

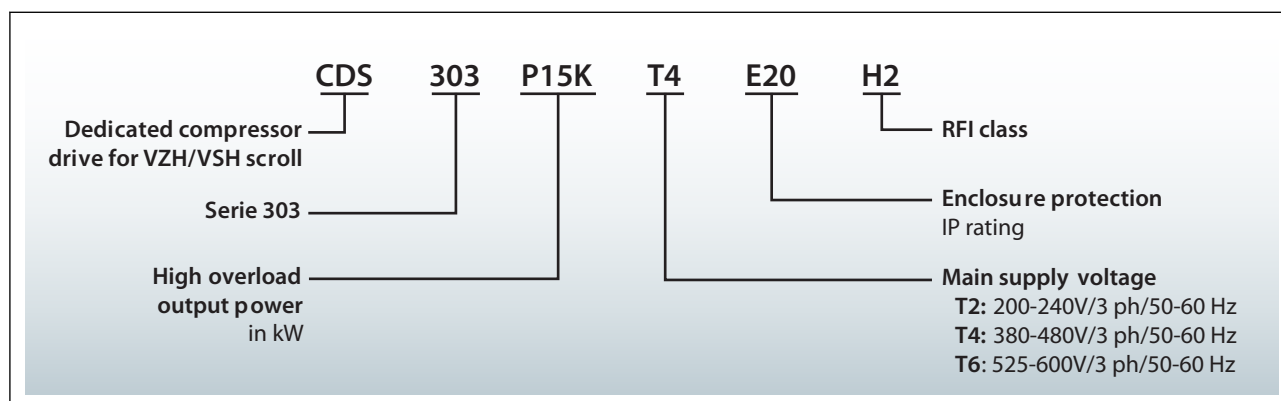

Technical specification

Frequency converter technical specifications

Table 25: Frequency converter technical specifications

Features	Description
Mains supply voltage	T2: 200 - 240 V \pm 10% (3-phase) T4: 380 - 480 V \pm 10% (3-phase) T6: 525 - 600V \pm 10% (3-phase)
Supply frequency	50 / 60 Hz
Output voltage	0 - 100 % of supply voltage
Inputs	6 digital (0-24V), 2 analog (0/ \pm 10V or 4-20mA, scalable)
Programmable outputs	2 digital (0-24V), 1 analog (0/4-20mA), 2 relay
Protection functions	Over-current protection, low / high current handling
Compressor functions	Motor protection, compressor ramp up/down control

Frequency converter variants

Different frequency converter variants are available according to:

1. Mains supply voltage
2. IP class (CDS303 drives are available in IP20 or IP55 housings)
3. RFI (Radio Frequency Interference) class H2/H3 or HX
4. Printed Circuit Board (PCB) coated or not coated.

Compressor and frequency converter combinations

When the compressor size and mains voltage have been defined in the above selection criteria, the code number tables from the [Ordering](#) and [Packaging](#) section provides the appropriate frequency converter sizes and up to eight corresponding code numbers for each compressor model.

i NOTE:

This compressor is equipped with a four poles electrical motor so the applied frequency from the inverter will be 50 Hz for 25 rps (1500 rpm) up to 200 Hz for 100 rps (6000 rpm). Please refer to the table below

Table 26: Compressor and frequency converter combinations

min./max.	Compressor speed		Drive output frequency
	rps	rpm	Hz
min.	25	1500	50
max.	100	6000	200

Dimensions

CDS303 Frequency converter dimensions

Frequency converter dimensions depend on supply voltage, IP rating and power. The table below gives an overview of the overall dimensions and different drive enclosures (B1 - B4). Details for each drive enclosure are on the following pages.

Figure 27: Frequency converter enclosure dimensions

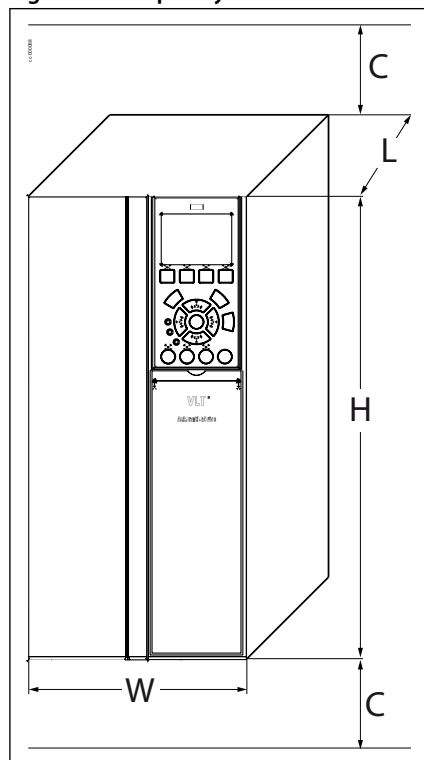

C Min. 100/200 Clearance above for cooling

Table 27: Frequency converter enclosure dimensions IP20

Drive supply voltage	Drive power kW	Compressor voltage code	Compressor model	IP20			
				Drive enclosure	Overall drive size [H x W x L] mm (inch)	Clearance above/below mm (inch)	bracket supplied (mm ²)
T2: 200-240/3/50-60	15	J	VZH088	B4	595x230x242 (23.43x9.09x9.53)	200 (8)	2pcs, ø24-28k28b 1pcs, ø32-36 k36b
	18.5		VZH117	C3	630x308x333 (24.8x12.13x13.15)	200 (8)	1pcs, ø32-36 k36b 1pcs, ø36-40 k40b
	22		VZH170	C3	630x308x333 (24.8x12.13x13.15)	200 (8)	1pcs, ø32-36 k36b 1pcs, ø36-40 k40b
T4: 380-480/3/50-60	15	G	VZH088	B3	420x165x249 (16.5x6.5x9.76)	200 (8)	3pcs, ø13-22
	18.5		VZH117	B4	595x230x242 (23.42x9.09x9.53)	200 (8)	2pcs, ø24-28 k28b
	22		VZH170	B4	595x230x242 (23.42x9.09x9.53)	200 (8)	2pcs, ø24-28 k28b
T6: 525-600/3/50-60	18.5	H	VZH088	B4	595x230x242 (23.42x9.09x9.53)	200 (8)	2pcs, ø24-28 k28b
	30		VZH117	B4	595x230x242 (23.42x9.09x9.53)	200 (8)	2pcs, ø24-28 k28b
	30		VZH170	B4	595x230x242 (23.42x9.09x9.53)	200 (8)	2pcs, ø24-28 k28b

Table 28: Frequency converter dimensions IP55

Drive supply voltage	Drive power kW	Compressor voltage code	Compressor model	IP55			
				Drive enclosure	Overall drive size [H x W x L] mm (inch)	Clearance above/below mm (inch)	bracket supplied (mm ²)
T2: 200-240/3/50-60	15	J	VZH088	C1	680x308x310 (26.78x12.13x12.20)	200 (8)	1pcs, ø32-36 k36b 1pcs, ø36-40 k40b
	18.5		VZH117	C1	680x308x310 (26.78x12.13x12.20)	200 (8)	1pcs, ø32-36 k36b 1pcs, ø36-40 k40b
	22		VZH170	C1	680x308x310 (26.78x12.13x12.20)	200 (8)	1pcs, ø32-36 k36b 1pcs, ø36-40 k40b
T4: 380-480/3/50-60	15	G	VZH088	B1	480x242x260 (18.9x9.45x10.24)	400 (4)	3pcs, ø3-32
	18.5		VZH117	B2	650x242x260 (25.6x9.53x10.24)	200 (8)	3pcs, ø3-32
	22		VZH170	B2	650x242x260 (25.6x9.53x10.24)	200 (8)	3pcs, ø14-40
T6: 525-600/3/50-60	18.5	H	VZH088	-	-	-	-
	30		VZH117	-	-	-	-
	30		VZH170	-	-	-	-

For customers who needs other size brackets, please refer to [Accessories and Spare parts](#) for ordering.

Figure 28: Drive outline dimensions

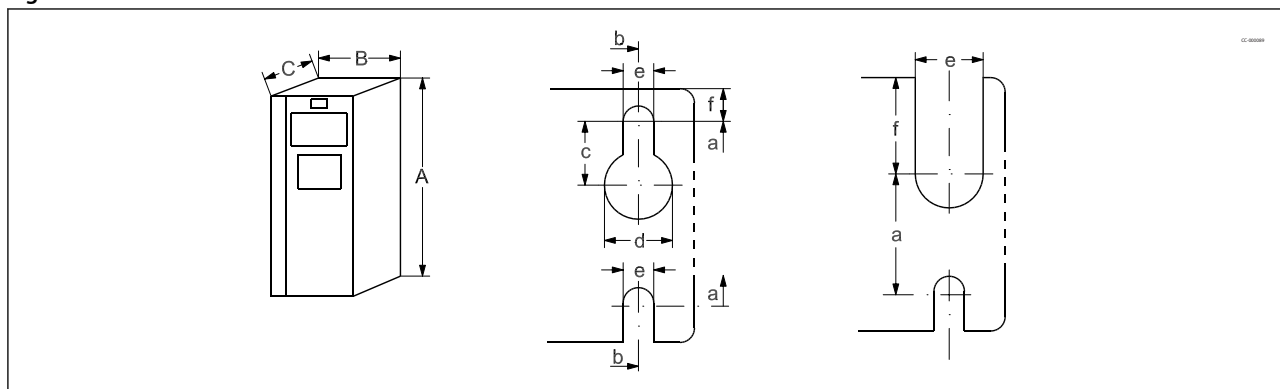

Table 29: Drive outline dimensions

Enclosure		Height						Width				Depth		Mounting hole						Max. Weight	
Frame	IP Class	A		A ⁽¹⁾		a		B		b		C		d		e		f		kg	lb
		mm	in.	mm	in.	mm	in.	mm	in.	mm	in.	mm	in.	mm	in.	mm	in.	mm	in.		
B1	IP55	480	18.9	-	-	454	17.87	242	9.53	210	8.27	260	10.24	19	0.75	9	0.35	9	0.35	23	51
B2	IP55	650	25.59	-	-	624	24.57	242	9.53	210	8.27	260	10.24	19	0.75	9	0.35	9	0.35	27	60
B3	IP20	399	15.71	420	16.54	380	14.96	165	6.5	140	5.51	249	9.8	12	0.47	6.8	0.27	7.9	0.31	12	26
B4	IP20	520	20.47	595	23.43	495	19.49	230	9.06	200	7.87	242	9.53	-	-	8.5	0.33	15	0.59	23	51
C1	IP55	680	26.77	-	-	648	25.51	308	12.13	272	10.71	310	12.2	19	0.75	9	0.35	9.8	0.39	45	99
C3	IP20	550	21.65	630	24.8	521	20.51	308	12.13	270	10.63	333	13.11	-	-	8.5	0.33	17	0.67	50	110

⁽¹⁾ Including decoupling plate.

NOTE:

The dimensions are only for the physical units, but when installing in an application it is necessary to add space for free air passage both above and below the units. The amount of space for free air passage is listed in “frequency converter dimensions - Clearance above/below (mm/inch)”.

Electrical connections

Wire sizes

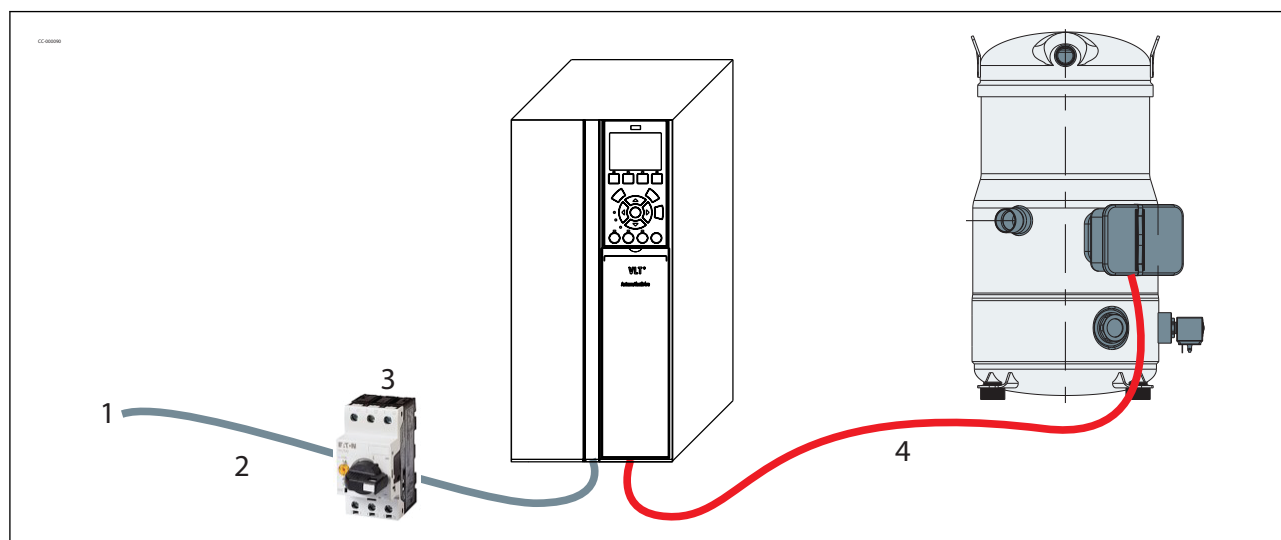

1	Power input	3	Circuit breaker
2	From network to drive	4	From drive to to compressor

Table 30: Maximum wiring sizes for the motor compressor power supply cables

Voltage range	From network to frequency converter			From frequency converter to compressor		
	Type	mm ²	AWG	Type	mm ²	AWG
200 - 240 V	CDS-15kW	25	4	VZH088-J	25	4
200 - 240 V	CDS-18.5 kW	35	2	VZH117-J	35	2
200 - 240 V	CDS-22 kW	50	1	VZH170-J	50	1
380 - 400 V	CDS-15 kW	6	10	VZH088-G	6	10
380 - 400 V	CDS-18.5 Kw	10	8	VZH117-G	10	8
380 - 400 V	CDS-22 kW	16	6	VZH170-G	16	6
525 - 600 V	CDS-18.5 kW (IP20)	10	8	VZH088-H	6	10
525 - 600 V	CDS-30kW (IP20)	25	4	VZH117-H	10	8
525 - 600 V	CDS-30kW (IP20)	25	4	VZH170H	16	6

NOTE:

The wire size values are the maximum size the converter can accept. The required cable size should be specified by the OEM depending on the unit design, ambient temperature, the wire material, current, etc...

Electrical specifications

Fuses / circuit breakers

Danfoss recommends using the fuses/circuit breakers listed below to protect service personnel and property in case of component break-down in the frequency converter. For circuit breakers, Moeller types have been tested and are recommended.

Table 31: Fuses / circuit breakers

Frequency converter		EN50178 compliant fuses		UL Compliant fuses						Recommended circuit breaker	
				Bussmann			SIBA	Little fuse		IP20	IP55
				Type RK1	Type J	Type T	Type RK1	Type RK1	Type RK1	Moeller type	
200-240 V	CDS-15kW	125 A	gG	KTN-R125	JKS-150	JJN-125	2028220-125	KLN-R125	A2K-125R	NZMB1-A100	NZMB2-A200
200-240 V	CDS-18.5 kW	125 A	gG	KTN-R125	JKS-150	JJN-125	2028220-125	KLN-R125	A2K-125R	NZMB2-A200	NZMB2-A200
200-240 V	CDS-22 kW	160 A	gG	FWX-150	-	-	2028220-150	L25S-150	A25X-150	NZMB2-A200	NZMB2-A200
380-480 V	CDS-15 kW	63 A	gG	KTS-R50	JKS-50	JJS-50	5014006-050	KLS-R50	A6K-50R	PKZM4-50	PKZM4-63
380-480 V	CDS-18.5 Kw	63 A	gG	KTS-R60	JKS-60	JJS-60	5014006-063	KLS-R60	A6K-60R	NZMB1-A100	NZMB1-A100

Frequency converter		EN50178 compliant fuses		UL Compliant fuses						Recommended circuit breaker	
				Bussmann			SIBA	Little fuse		IP20	IP55
		Size	Type	Type RK1	Type J	Type T	Type RK1	Type RK1	Type RK1	Moeller type	
380-480 V	CDS-22 kW	80 A	gG	KTS-R80	JKS-80	JJS-80	2028220-100	KLS-R80	A6K-80R	NZMB1-A100	NZMB1-A100
525-600V	CDS-18.5 kW	40A	gG	KTS-R50	JKS-50	JJS-50	5014006-050	KLS-R50	A6K-50R	NZMB1-A100	-
525-600V	CDS-30 kW	63A	gG	KTS-R80	JKS-80	IJS-80	5014006-080	KLS-R80	A6K-80R	NZMB1-A100	-

Soft-start control

The CDS303 frequency converter generates by design a compressor soft start.

Current inrush will not exceed the frequency converter maximum current.

Basically seen from the mains, the inrush peak reach a level which is only a few percent more than the rated nominal current.

Drive installation

Direct and indirect exposure of drive to water

IP20 drives are intended for indoor or cabinet mounting. Application example: drive fitted in a machine room, basement or in an electrical cabinet together with other electric / electronic components such as the unit controller or contactors.

For outdoor use the electrical cabinet must be IP54 or the drive itself must be IP54 at least. Application example: rooftop units or condensing units.

If IP54 with LCP make sure that the gasket is applied to ensure tightness.

It is recommended to place drive at least 30cm (11.81 inches) from ground to protect against floods.

Dust Exposure

Avoid dust from depositing on the drive surface, circuit boards and other electric components. These deposits act as insulation layers and hamper heat transfer to the ambient air, reducing the cooling capacity. The increased heat load causes an accelerated aging of the electrical components, thus decreasing the service life. Dust deposits that accumulate on the heat sink located on the back of the VFD will also decrease the service life of the unit.

The drive cooling fans have small bearings into which dust can penetrate and act as an abrasive. This leads to bearing damage and fan failure.

Under the conditions described above, it is advisable to clean the frequency converter during periodic maintenance. Remove dust off the heat sink and fans and clean the filter mats.

Mechanical Mounting

For optimal cooling conditions, mount the drive on vertical position. Allow a free air passage above and below the frequency converter. See [Table 32: Mounting the drive](#)

Figure 29: Mounting the drive

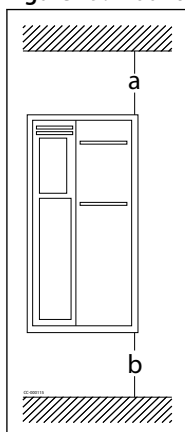

Table 32: Mounting the drive

Enclosure type ⁽¹⁾	B1	B2/B3/B4/C1/C3	C2/C4
a (mm/inch)	100/3.94	200/7.87	225/8.86
b (mm/inch)	100/3.94	200/7.87	225/8.86

⁽¹⁾ Enclosure please refer to drive enclosure table in section “CDS303 Frequency converter”.

Horizontal mounting is NOT the preferred position, however if unavoidable, lay PCB on the left side (270°) to avoid condensation accumulation on the electronics.

Drive ambient temperature

⚠ The maximum ambient temperature for the drive is 50°C (122°F). (24-hour average maximum 45 °C). Do not exceed the maximum temperature limit. The drive could operate lower to -10°C (14°F) with proper operation, such as inside the cabinet, install the space heater. LCP operating temperature is -10 - 50 °C.

High Ambient Temperature

Test at the unit’s at highest ambient maximum load is recommended. Look for over temperature alarms. Guidelines that support high ambient temperature:

- Ensure clearance limits above and below the drive for air circulation are respected.
- The drive must be installed on a panel wall or on a back plate to ensure proper cooling
- Do not place the drive under direct sunlight.
- Insulation inside the electrical panel can reduce impact of sun radiation.
- Additional air conditioning of the cabinet may be required.

The frequency converter has built-in temperature sensors and reacts immediately to critical values via hard-coded limits. In case of over-temperature inside the frequency converter, it automatically derates the switching frequency and the maximum allowed output current to reduce the internal heat. This can cause the compressor to trip due to insufficient current to drive the compressor.

Oversizing the drive for high temperature operations

Should the application require full compressor envelope at high ambient temperature, then the CDS303 must be oversized to have better heat dissipation and deliver nominal current to the compressor.

For selection and further information, please contact Danfoss.

EMC

Frequency converter (and other electrical devices) generate electronic or magnetic fields that may interfere with their environment. The electromagnetic compatibility (EMC) of these effects depends on the power and the harmonic characteristics of the devices.

The EMC product standard for frequency converters defines 4 categories (C1, C2, C3, and C4) with specified requirements for emission and immunity. **Table 33: Categories for EMC product standard** states the definition of the 4 categories and the equivalent classification from EN 55011.

Table 33: Categories for EMC product standard

Category	Definition	Equivalent emission class in EN 55011
C1	Frequency converters installed in the first environment (home and office) with a supply voltage less than 1000 V.	Class B
C2	Frequency converters installed in the first environment (home and office) with a supply voltage less than 1000 V, which are not plug-in and not movable, and must be installed and commissioned by a professional.	Class A Group 1
C3	Frequency converters installed in the second environment (industrial) with a supply voltage lower than 1000 V.	Class A Group 2
C4	Frequency converters installed in the second environment with a supply voltage equal to or above 1000 V or rated current equal to or above 400 A or intended for use in complex systems.	No limit line. Make an EMC plan

VZH compressor with drive package achieve EMC Class A Group 1 emission and immunity requirements.

EMC best practices

- Use screened (shielded) cables for motor, control wiring and communication.
- Separate cables for input power, motor wiring and control wiring. Failure to isolate power, motor, control and communication cables can result in unintended behavior or reduced performance. Minimum 200 mm (7.9 in) clearance between power, motor and control cables is required.
- Ensure VFD proper grounding
- Motor cables should be as short as possible to reduce noise level and leakage currents.

Figure 30: EMC correct installation of an frequency drive CDS303

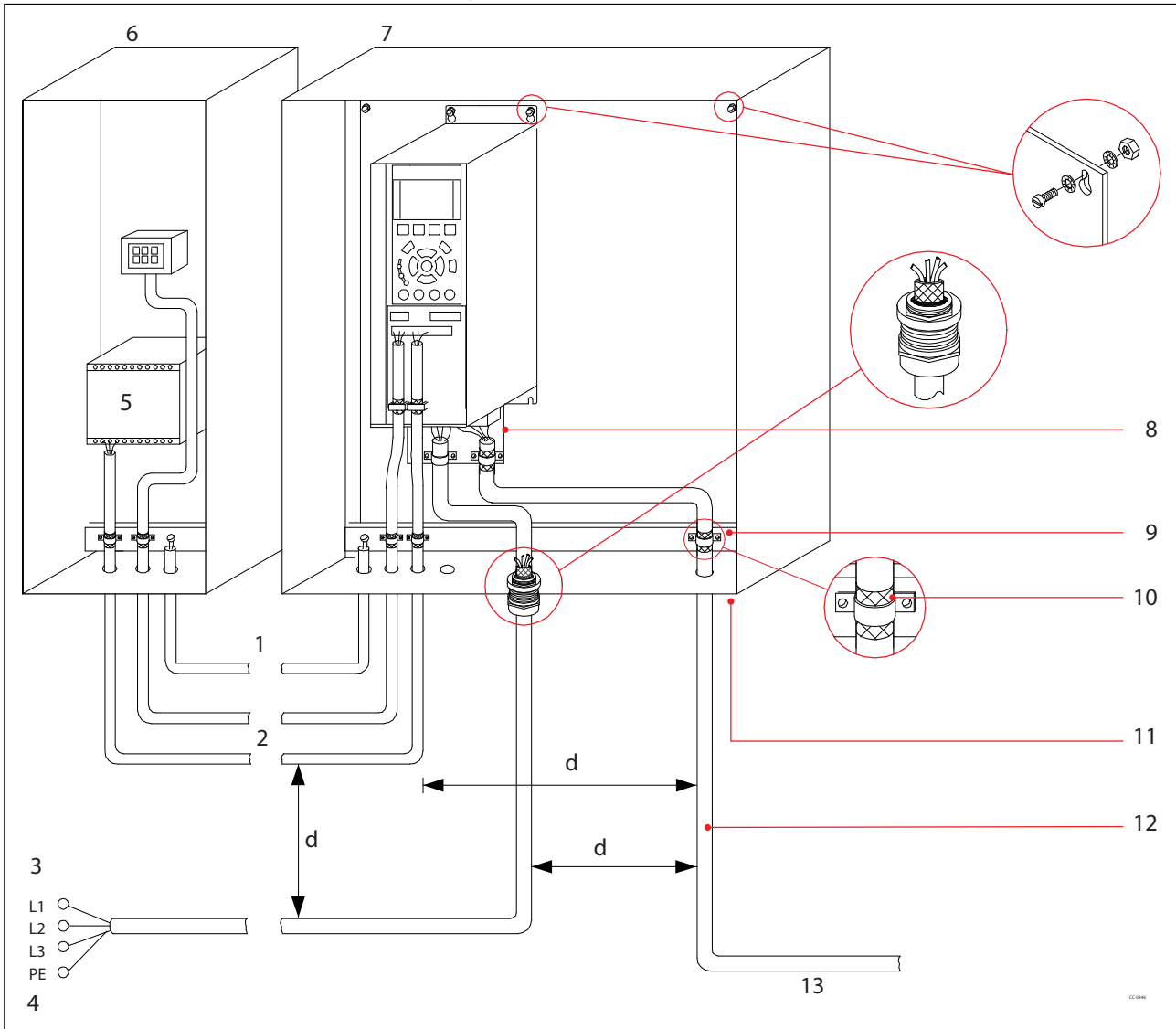

1	Min. 0.025 in ² (16 mm ²) Equalizing cable	8	Decoupling plate
2	Control cables	9	Grounding rail
3	Mains supply	10	Cable insulation stripped
4	Reinforced protective ground	11	All cable entries in one side of panel
5	PLC	12	Motor cable
6	PLC etc.	13	Motor, 3 phases and protective ground
7	Panel	d	Min. 7.9 in (200 mm) between control cables, motor cable and mains cable

EMC qualification reports are available upon request to Danfoss technical support.

Troubleshooting

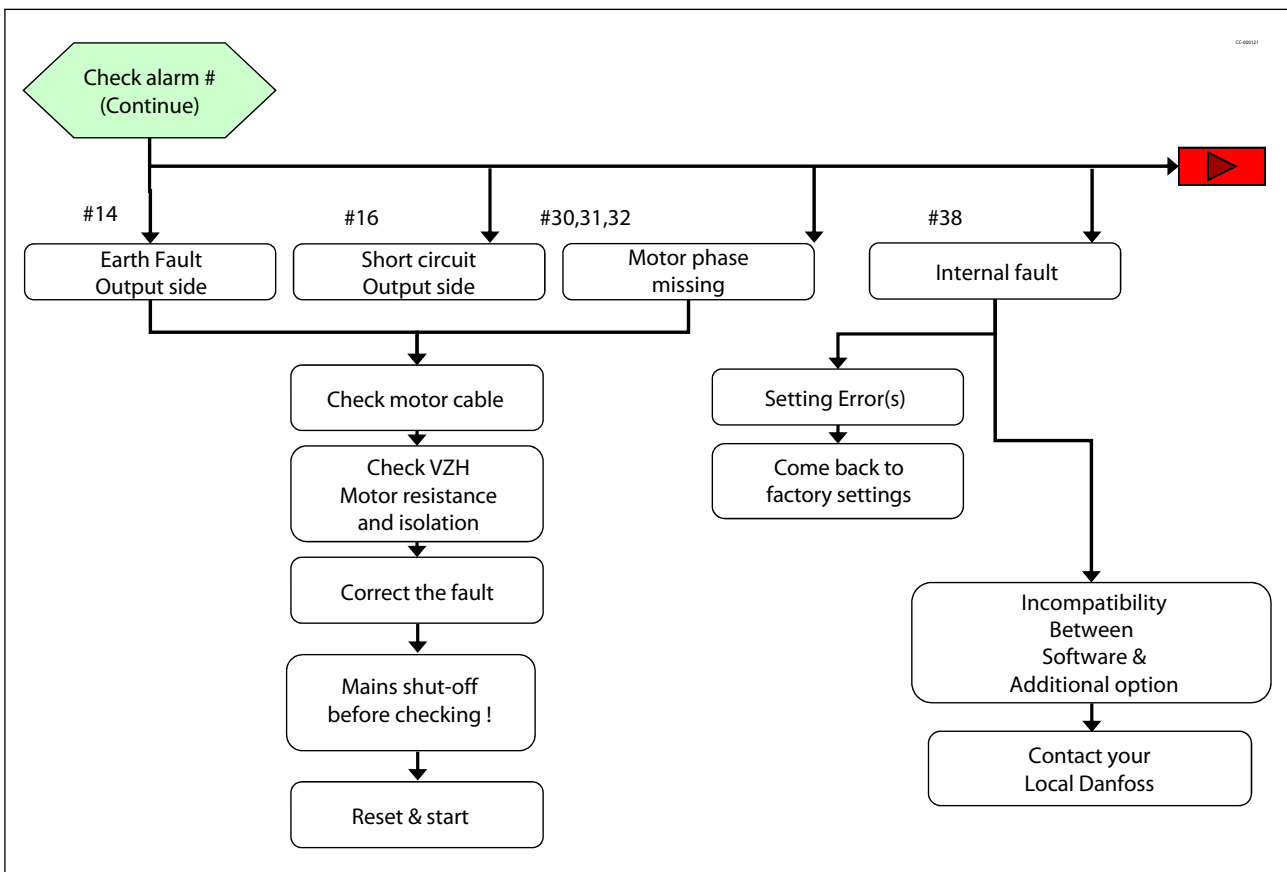
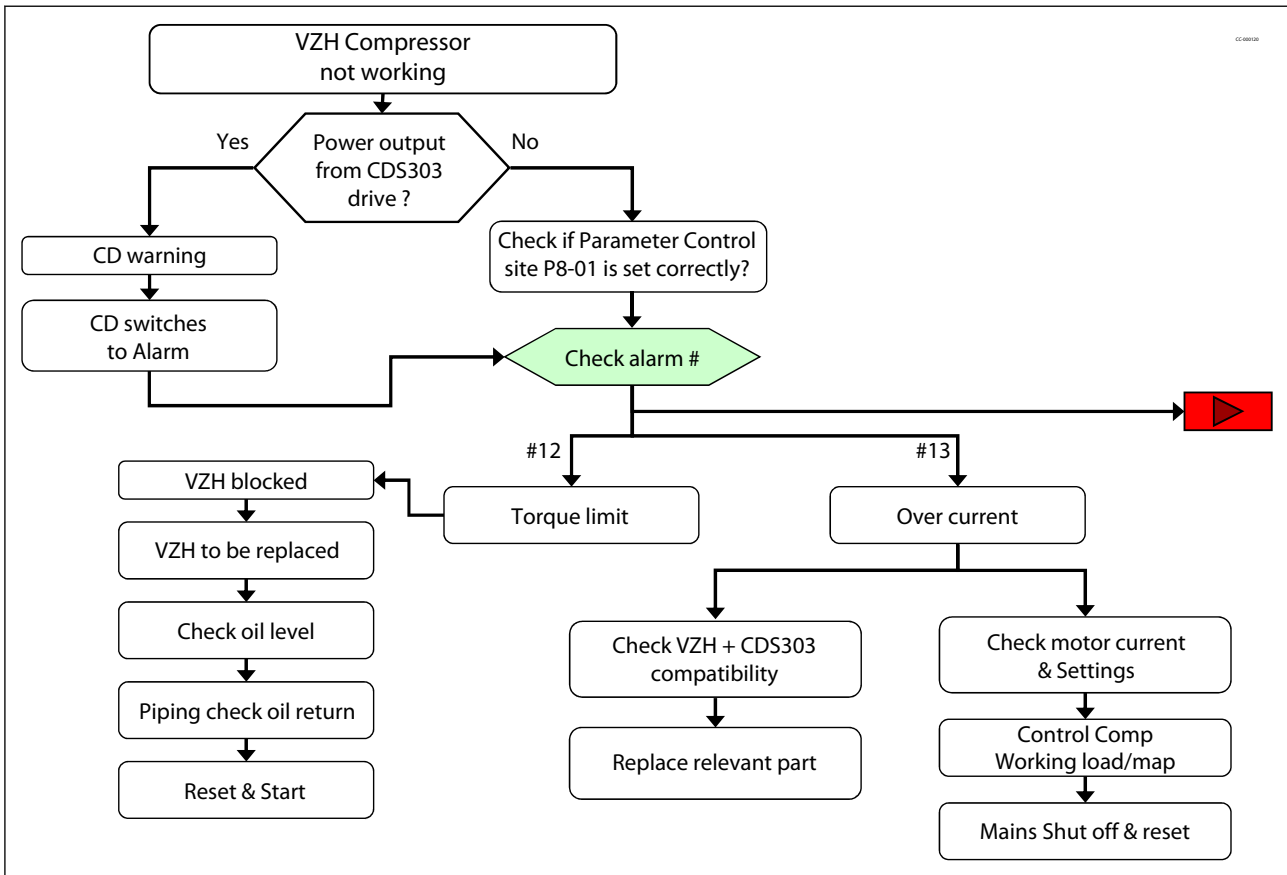

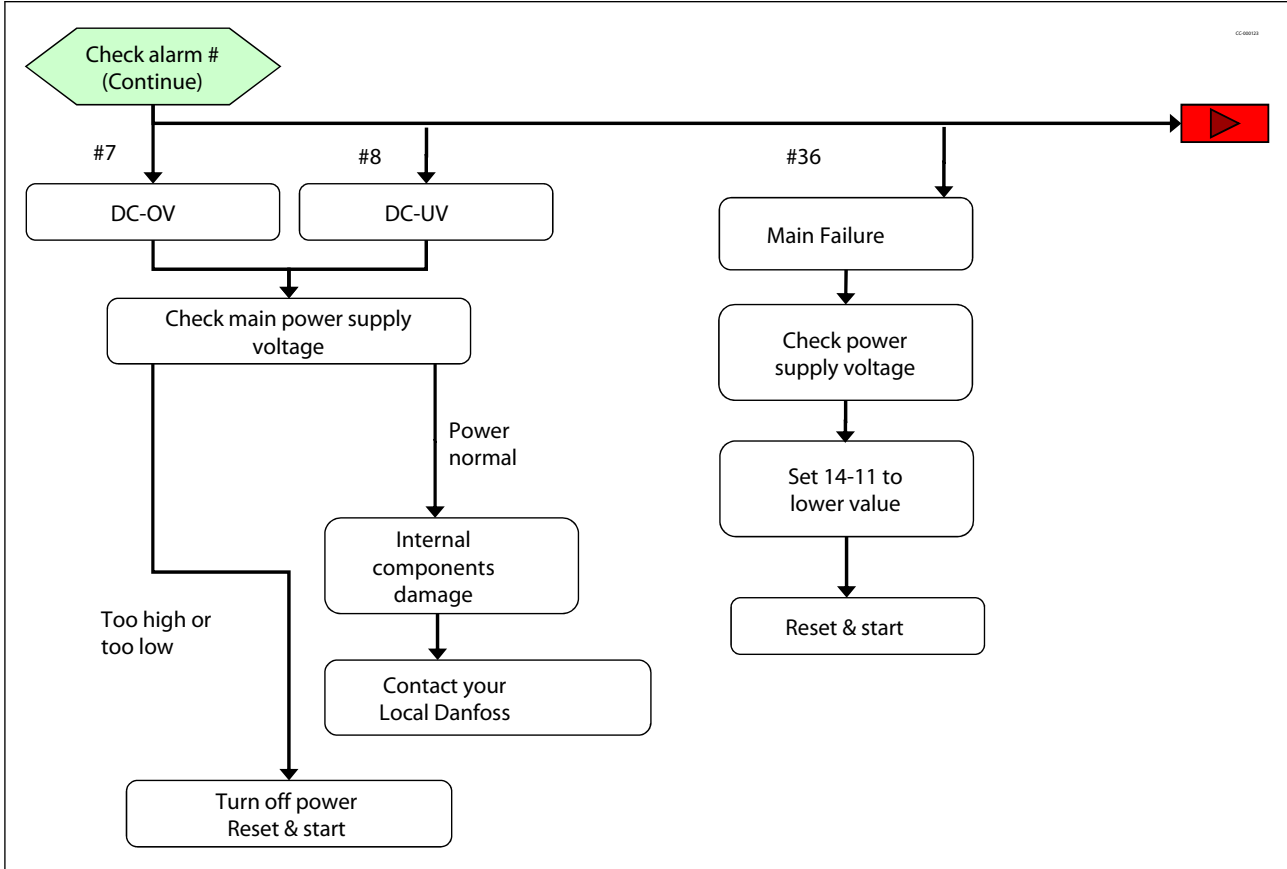
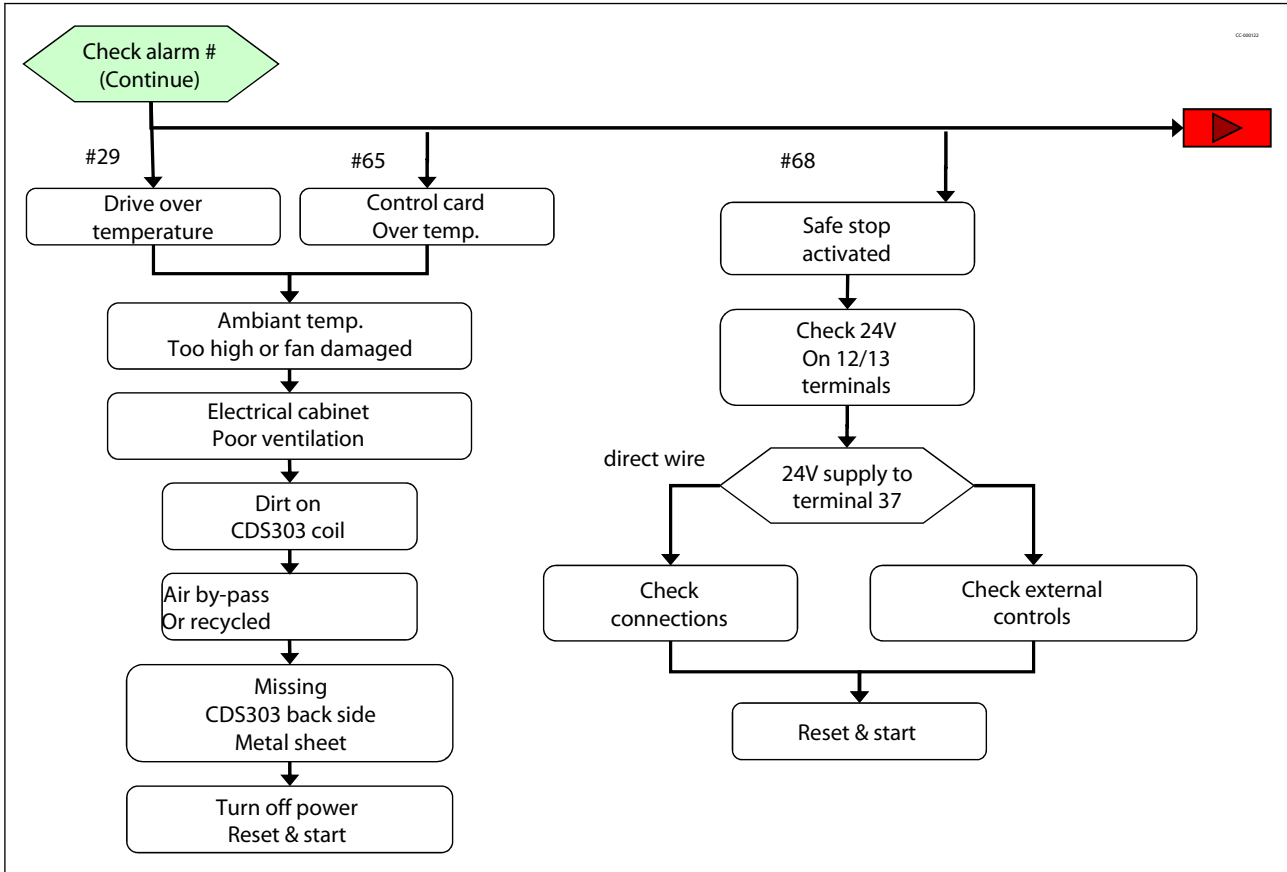

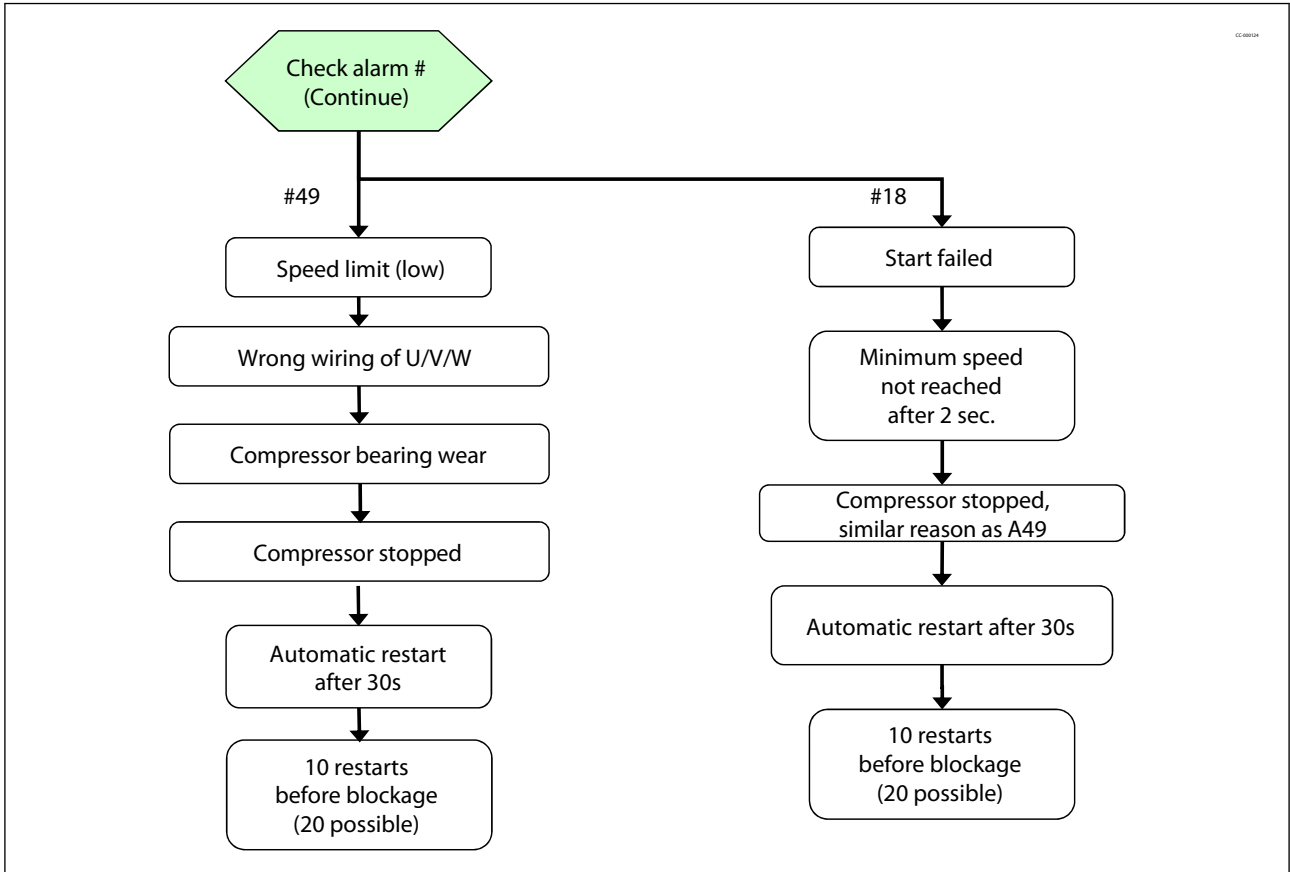

Compressor and drive control

Typical control architecture

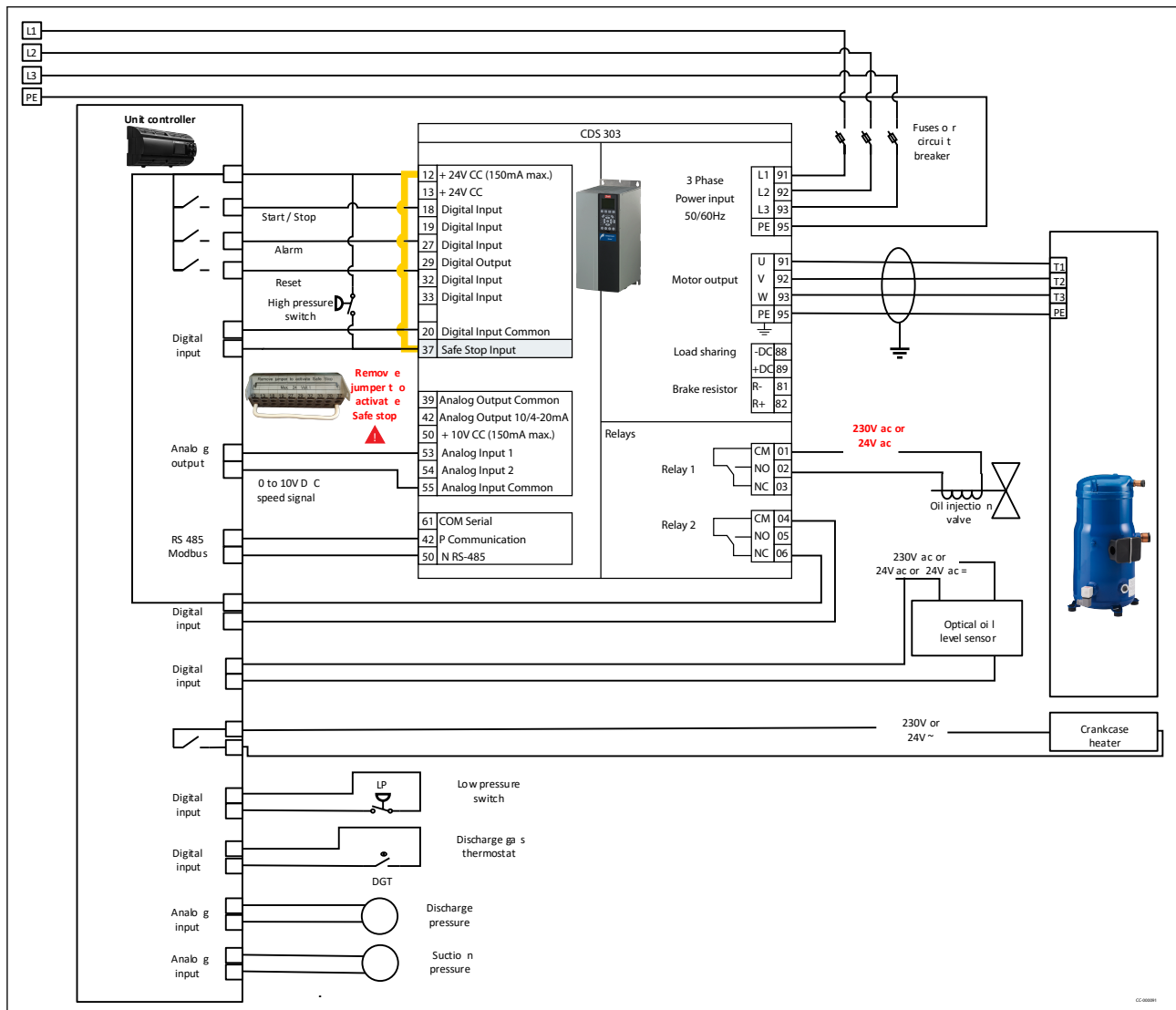

Oil injection control

Oil injection solenoid valve is controlled by CDS303 drive through pre-configured Relay 1. More details in [Technical specification](#)

Compressor start and stop, speed control

⚠ Speed limit guarantees compressor reliability and must be respected. In drive control logic, default setting values have been qualified by Danfoss. It is not recommended to change default values.

Figure 31: Start/Stop/Ramp setting

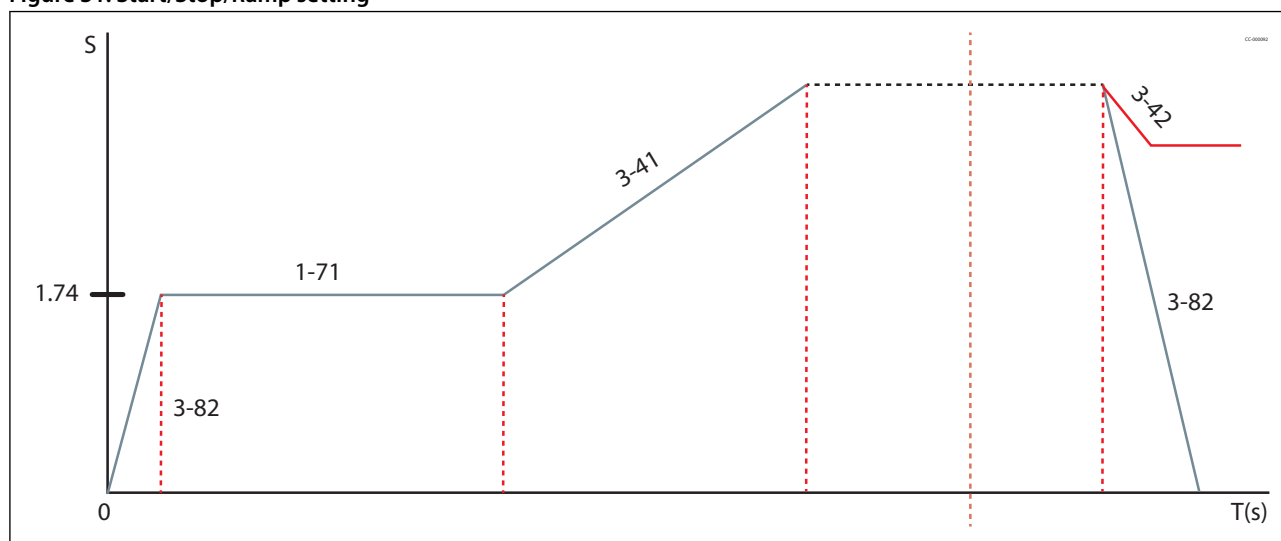

S Speed

T(s) Time

Table 34: Start/Stop/Ramp setting

Drive parameters	Description	Default value (recommended)	Range
1.71 Start delay (s)	Start-up sequence: at start, compressor runs at start speed (1.74) during the Start delay (1.71) During this time the speed set-point is ignored	60sec	10-300s
1.74 Start speed (RPS)	Start-up sequence: at start, compressor runs at start speed (1.74) during the Start delay (1.71) During this time the speed set-point is ignored	30rps / 1800rpm	30-60rps / 1800-3600rpm
3.41 Ramp 1 ramp up time (s)	Defines speed ramp up slope. Ramp 1 ramp up time (s) is the time it takes to increase compressor speed from 0rps to 90rps. It is a linear ramp thus gives constant acceleration during ramping. Eg: if current speed is 55rps and desired speed is 100rps, then compressor will take 90sec $(180\text{sec}/90\text{rps}) * (100-55)\text{rps} = 90\text{sec}$	180sec	15-3600s
3.42 Ramp 1 ramp down time (s)	Defines speed ramp down slope. in similar way that ramp-up.	180sec	15-3600s
3.82 Starting/stopping ramp Time (s)	Fast acceleration from standstill to minimum speed with a quick ramp. The start / stop command bypasses the normal ramp time and the frequency converter ramps the compressor fast.	2sec	0-5s

Short cycle protection

⚠ Minimum run time is necessary to ensure proper oil return to the compressor. A 3 minute minimum run time is usually recommended but some systems may require more time to establish proper superheat and stable oil return. Additionally, compressor must not exceed a maximum of 12 starts per hour. 12 starts per hour must not be considered as an average, this is the maximum number of starts acceptable to keep a good regulation accuracy during low load. Short cycle protection can be done either by the drive or the unit controller. The following table describes the parameters to adjust depending on which short cycle protection is selected.

Table 35: Short cycle protection

Drive parameters	Description	Value	Default
Short cycle protection is done by unit controller			
28.00 Short cycle protection	Short cycle protection done in unit controller: (preferred option)	Disable	Enable
Short cycle protection is done in drive; If short cycle protection enabled in drive, the Terminal 18 start/stop will be ignored during minimum run time. To be able to stop compressor during this minimum run time (Low pressure trip..), it is necessary to use Terminal 27 (Par 5.12) and set it to "Coast inverse" If Modbus is used it is not necessary to connect terminal 27, but a "Coasting" command must be sent to be able to stop compressor in case of an alarm during minimum run time.			
28.00 Short cycle protection	Short cycle protection done by the drive.	Enable	Enable

Drive parameters	Description	Value	Default	
28.01	Interval between starts	Start command is ignored until the timer (300s) has elapsed. Only then, can the compressor start.	300 sec	300sec
28.02	Minimum Run time	The compressor cannot stop until the set time (180s) has elapsed. The timer starts counting following a compressor start. Stop command is ignored. Only a coast (inverse) command can override the time and stop the compressor.	180 sec	180sec
5.12	Terminal 27 Digital input	Designated for the LP switch.	[2]* Coast inverse	coast inverse

NOTE:

The short cycle protection function is not functional during Hand On control of the frequency converter via the LCP. If selecting Hand On or Off, the two timers will be reset to 0, and not start counting until Auto is pressed and an active start command applied. The counters are not available for display or monitoring.

The diagram below demonstrates how the function works:

Figure 32: Short cycle protection

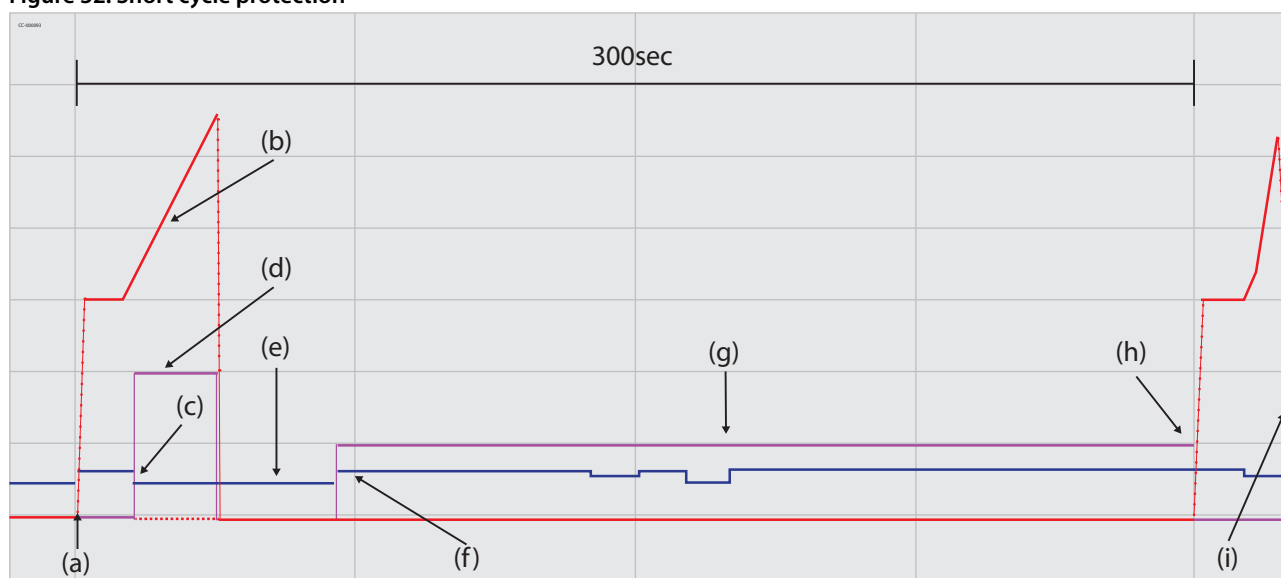

(a)	Start signal is given by the unit controller
(b)	Compressor started
(c)	Compressor stop requested by the unit controller
(d)	Stop command is ignored. Stop delay warning (W97).
(e)	Compressor stops when minimum run time (180s) has elapsed.
(f)	Start signal is given by the unit controller
(g)	Start command is ignored
(h)	Compressor starts after the timer interval between starts (300s) has elapsed.
(i)	Compressor Coast (stop) This command can override the time minimum run time and stop the compressor immediately.
300sec	Interval between starts

Drive alarm

⚠ Drive alarms can be a problem with the drive itself or with the compressor. It is necessary to identify the alarm code to determine appropriate trouble shooting actions.

Drive alarms will trip the compressor; therefore, the unit controller must get a feedback that the drive is in a fault condition.

The feedback is typically via drive Relay 2 output. This can also be done via digital output or modbus.

By default, alarms are reset automatically after 30s and the compressor restarts.

If the specified number of automatic resets (10x) is reached within 10 minutes, the drive enters manual reset mode.

Manual reset is via [Reset] key on the LCP, the digital input T32 or via Modbus. After the manual reset is performed, the drive reset mode returns to automatic reset.

If an alarm cannot be reset, the reason may be that its cause has not been rectified, or the alarm is trip-locked.

Trip lock

Alarms that are trip-locked offer additional protection, meaning that the mains supply must be switched off before the alarm can be reset. After being switched back on, the frequency converter is no longer blocked and may be reset as described above once the cause has been rectified.

Table 36: Trip lock

Par. nr.	Name	Set value	Default value
5-40.1	Relay Function	Alarm	VLT Running
14-20	Reset Mode	Automatic reset x10	Automatic reset x10
14-21	Automatic reset time	30s	30s

Stop compressor in case of safeties (LP, HP, DGT)

Table 37: Stop compressor in case of safeties (LP, HP, DGT)

Safeties	Tripping conditions		Re-start conditions	
	Value	Time	Value	Time
HP safety switch	See Pressure setting and max DGT in Operating envelope data	Immediate, no delay. No by-pass	Conditions back to normal Switch closed again	Manual reset
LP safety switch				Manual or Automatic Maximum
DGT external				5 auto reset during a period of 12 hours, then manual reset.

4 Way valve control and defrost logic

 The main challenge of a system equipped with a 4-way valve is during the time of the switch period. After that switch, condenser becomes evaporator and vice versa. Pressurized liquid in condenser directly flows to the compressor suction and lead to oil dilution and in extreme case, liquid slugging.

Liquid flood back due to reversing cycle can be reduced by using pressure to transfer liquid refrigerant from one exchanger to the other before the 4-way valve switch. Following flow chart describes the sequence.

Time and pressure difference have to be fine tuned during system qualification. EXV Opening degree and time have to be set to keep a minimum pressure difference to allow 4-way valve switch.

In any case, defrost logics must respect requirements and tests described in [Manage Superheat](#) and [Operating envelope data](#) sections.

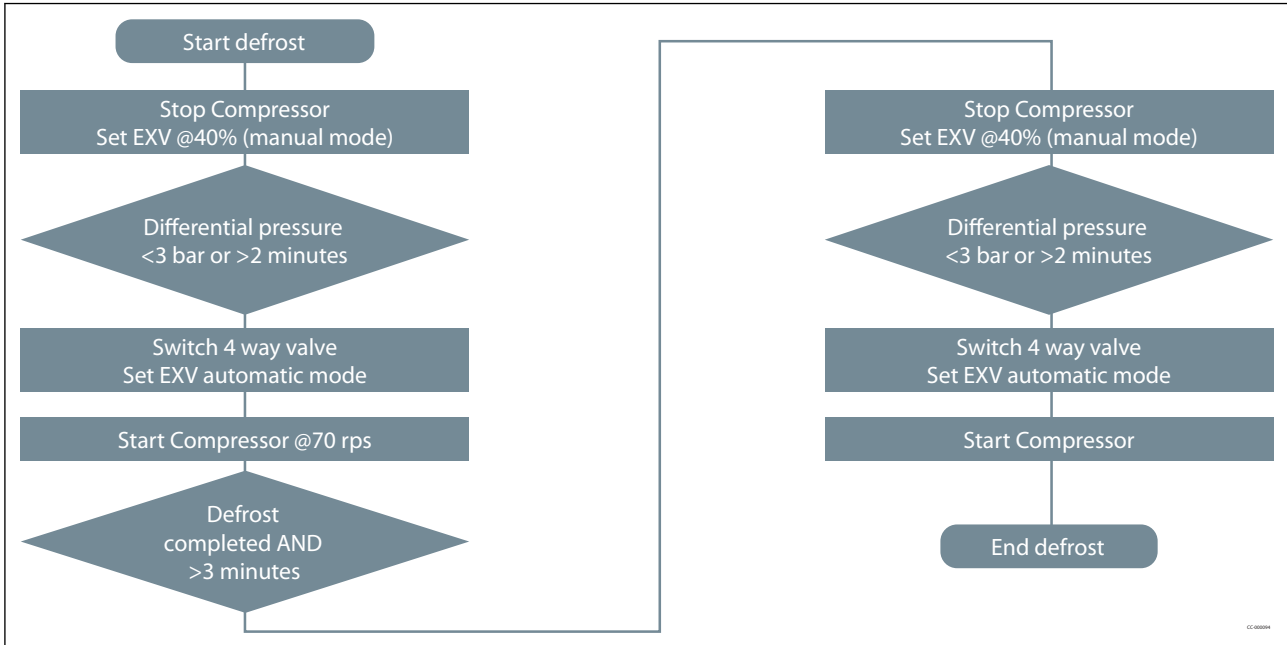

Unit remotely controlled

⚠ If the system demand, and thus compressor speed, can be controlled remotely, for example by a building management system (BMS), it is essential to make sure the demand signal is consistent. Unit controller shall not directly transmit demand from external signal to compressor. Table below show some examples of erratic external demand signal and possible preventions.

Figure 33: Unit remotely controlled

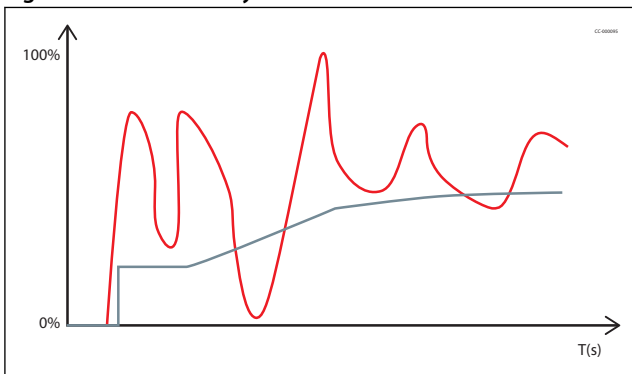

—	External signal demand
—	Compressor speed
T	Time

Table 38: Unit remotely controlled

System demand request	Example of prevention
Demand request changing very fast and often from 0 to 100%	Start in low load and ignore demand signal for the first 5 minutes and then smooth demand signal
Very frequent start and stop request	Ignore stop request for the first 5 min
Very frequent change from cooling to heating and vice versa	Do not allow change from cooling to heating and vice versa in less than 2h

Application Guideline

Manage Operating envelope

Requirement

⚠ The solid line envelope is valid for a suction superheat within 5K (9°F) at nominal voltage. Higher suction superheat may lead to discharge temperatures above “135°C”.

Moreover, the discharge gas temperature must not exceed “135°C”

The **Operating envelope** for “VZH088/117C and VZH170C” guarantees reliable operations of the compressor for steady-state operation.

High pressure switch

⚠️ The high-pressure switch must be set at or below “Maximum high pressure switch setting”. The high-pressure switch must never be bypassed or delayed and must be placed in a lockout circuit to prevent cycling.

If a discharge valve is used, the HP switch must be connected to the service valve gauge port, which cannot be isolated.

For CDS303 drive, HP switch can be connected to STO (Safe Torque Off) input 37 or to an external contactor placed between drive and compressor. Must remove the jumper (factory supplied) before connecting HP switch on terminals T37 and T12.

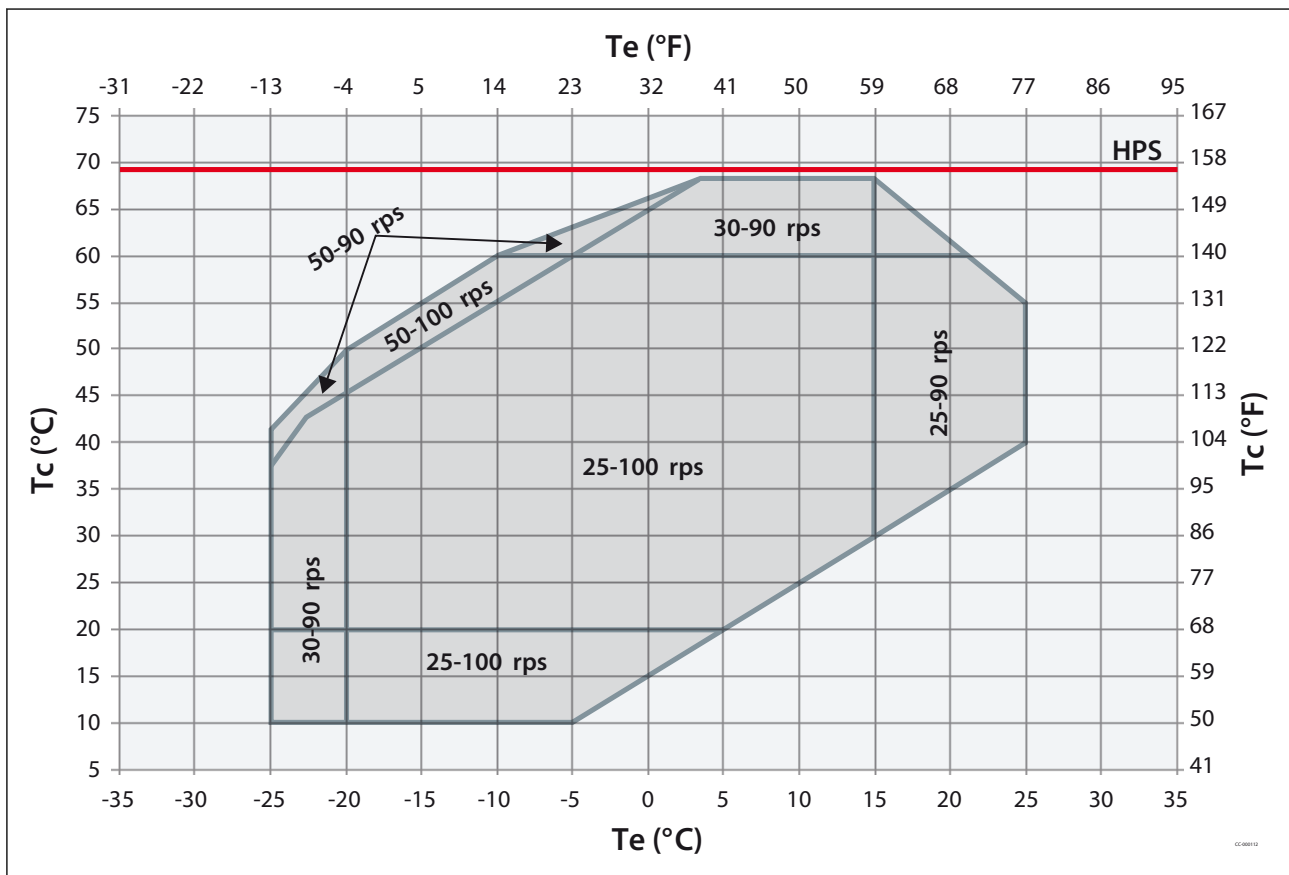

HPS High pressure switch

Low pressure switch

⚠ The low-pressure switch must be set at or above “Minimum Low pressure switch setting”. Operating at low pressures may cause damage to the compressor due to low mass flow through it. The LP switch must be an immediate, no delay feature.

The switch can be integrated directly in the safety chain of the compressor or it can be treated by the unit controller.

For a manual or automatic reset, there is a maximum of 5 auto resets during a period of 12 hours. After this threshold is crossed, a manual reset will be required.

If the LP switch is connected to Terminal 27 Digital Input, it is necessary to keep a parameter of 5.12 to default value “coast inverse” to make sure LP cut-out has a higher priority than internal minimum run time function.

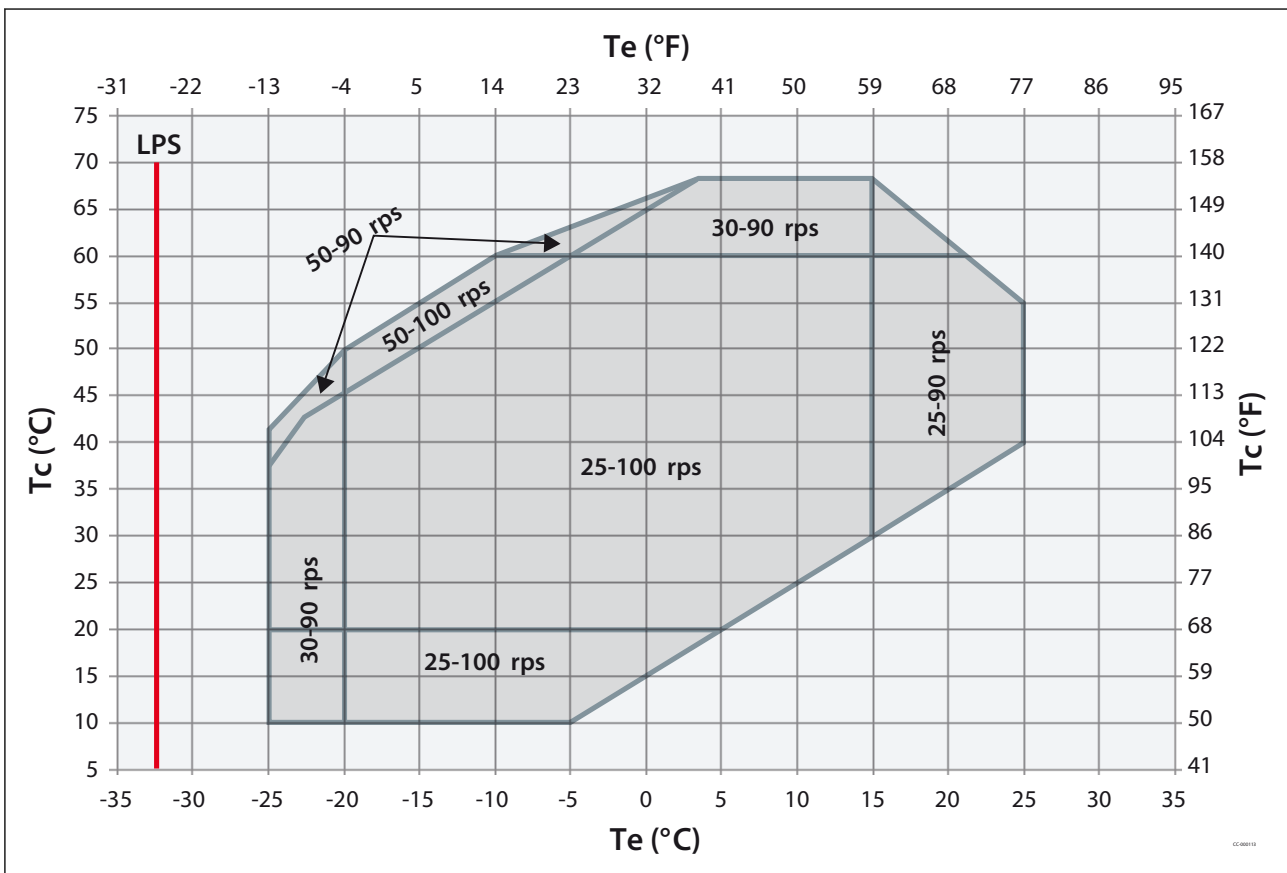

LPS Low pressure switch

Discharge temperature protection

⚠ Discharge gas thermostat protection (DGT) is required if the high and low pressure switch settings do not protect the compressor against operations beyond its specific application envelope (example)

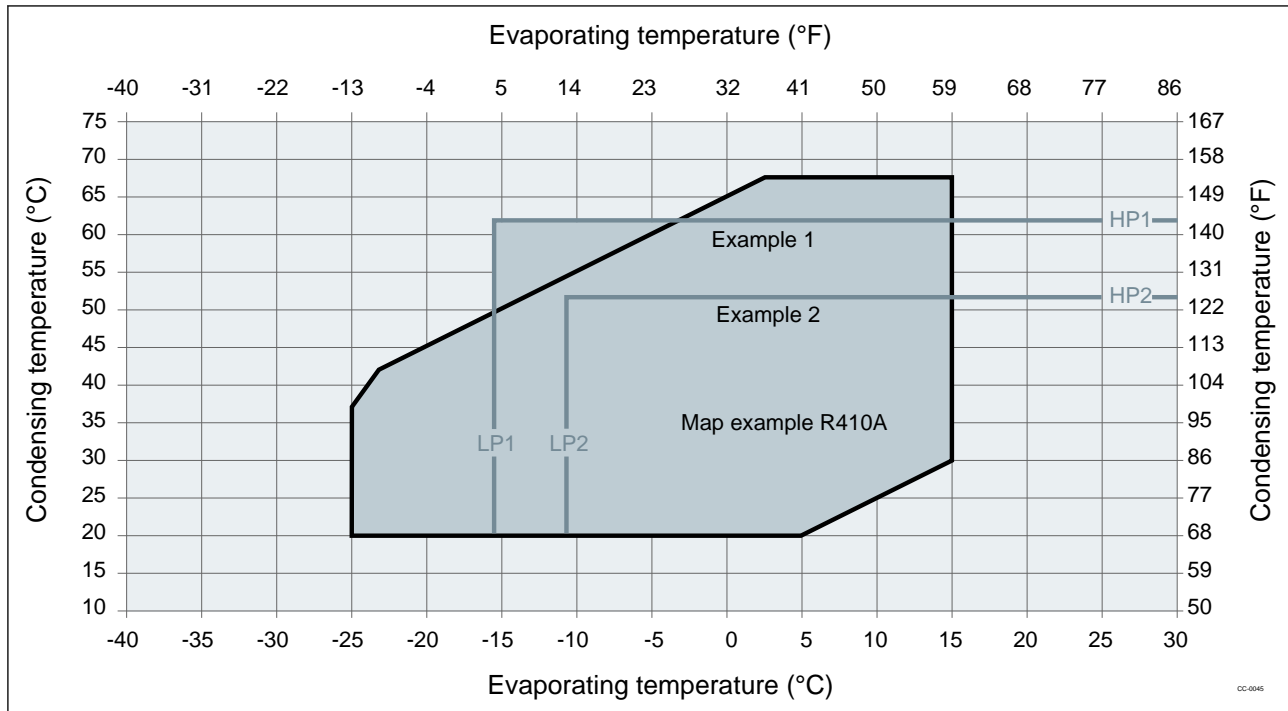

Example 1 (R410A, SH = 6K/10.8°F)

LP switch setting: LP1 = 3.3 bar (g) (-15.5°C/4.1°F)
 HP switch setting: HP1 = 38 bar (g) (62°C/143.6°F)
 Risk of operation beyond the application envelope.
 DGT protection required.

Example 2 (R410A, SH = 6K/10.8°F)

LP switch setting: LP2 = 4.6 bar (g) (-10.5°C/13.1°F)
 HP switch setting: HP2 = 31 bar (g) (52°C/125.6°F)
 No risk of operation beyond the application envelope.
 No DGT protection required.

The discharge gas thermostat accessory kit (code7750009) includes all components required for installation as shown on the right. DGT installation must respect the below requirements:

1. The thermostat must be attached to the discharge line within 150mm (5.91inch) from the compressor discharge port and must be thermally insulated and tightly fixed on the pipe.
2. The DGT should trip the compressor at a discharge gas temperature of 135°C (275°F) or lower. Manual or Automatic Reset - maximum of 5 auto resets during a period of 12 hours, then manual reset is required.

The switch can be integrated directly in safety chain of compressor or treated by unit controller. With variable speed compressors, the thermostat can be replaced by a discharge temperature sensor, then the unit controller can decrease compressor speed to keep the discharge temperature lower than the limit.

The discharge gas thermostat is an excellent protection against failure due to loss of refrigerant.

Figure 34: Discharge temperature protection

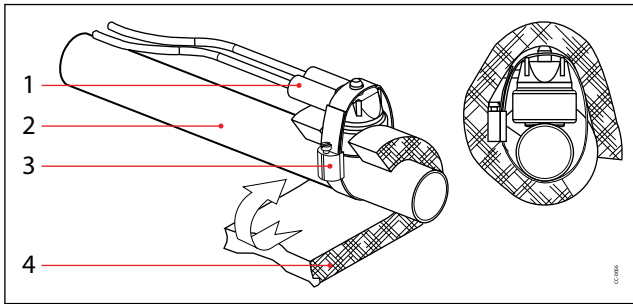

1	Thermostat
2	Discharge line
3	Bracket
4	Insulation

Protection and control of envelope

Low pressure (LP) switch and high pressure (HP) switches are necessary to protect the compressor. Depending on high pressure and low pressure limitations, a discharge gas thermostat (DGT) may also be necessary, see **Discharge temperature protection**.

For variable speed compressors, it is recommended that the unit controller continuously controls evaporating and condensing temperatures to check that the compressor is running within the defined envelope. This solution offers much better protection than only basic protection (HP, LP, DGT), and offers the possibility to adjust running conditions to avoid tripping (for example reduce compressor speed when reaching high pressure limit).

Operation of VZH is not allowed across the envelope at all speeds. Depending on speed range needed and unit controller capability, two types of envelope controls can be considered:

1. Limited speed range to have only one envelope Example 1
2. Full speed range with unit controller maintaining speed according to evaporating and condensing temperature Example 2

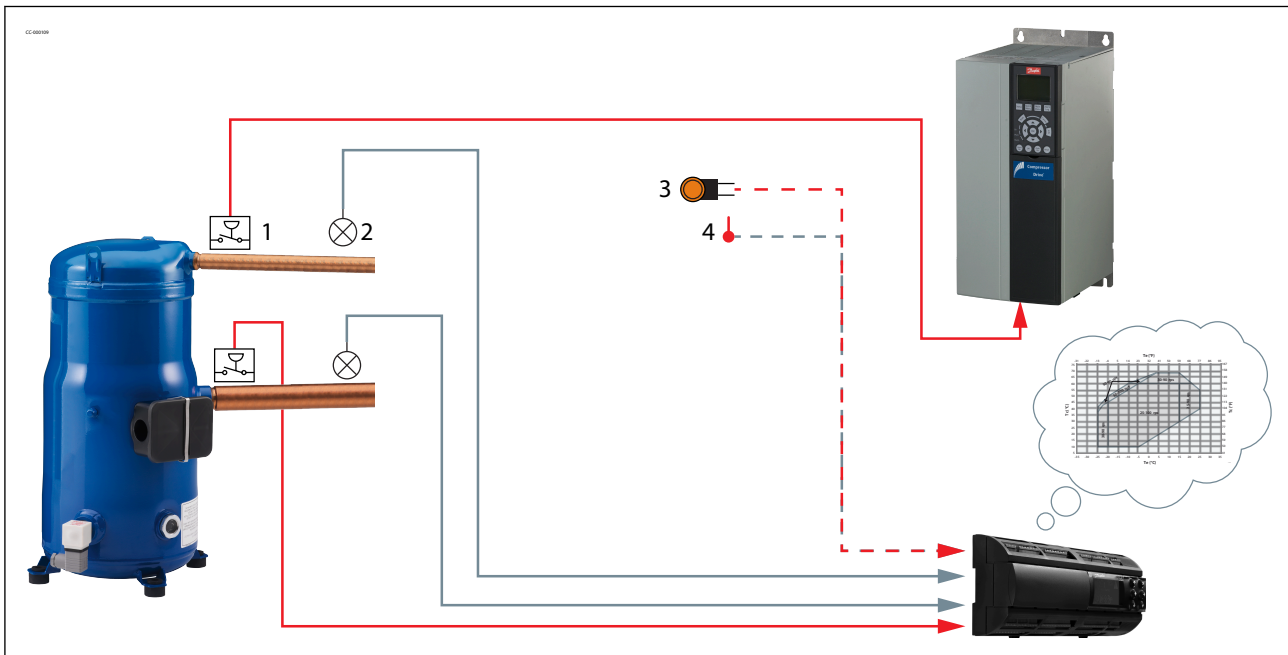

1	Pressure switches
2	Pressure sensor
3	Discharge thermostat
4	Temperature sensor
— (Red)	Protection
— (Blue)	Control

Example 1 with limited speed range from 30rps (1800rpm) to 90rps (5400rpm)

Safeties required High pressure switch, Low pressure switch, Discharge gas thermostat set @135°C (275°F) if necessary see [Discharge temperature protection](#)

Drive setting Adjust the minimum and maximum reference (speed setpoint) limits accordingly:

Par. 3-02 Minimum reference 1800 rpm (30 rps).

Par. 3-03 Maximum reference 5400 rpm (90 rps).

Envelope control The unit controller continuously measures evaporating and condensing temperatures in order to maintain the compressor within the envelope independently of compressor speed.

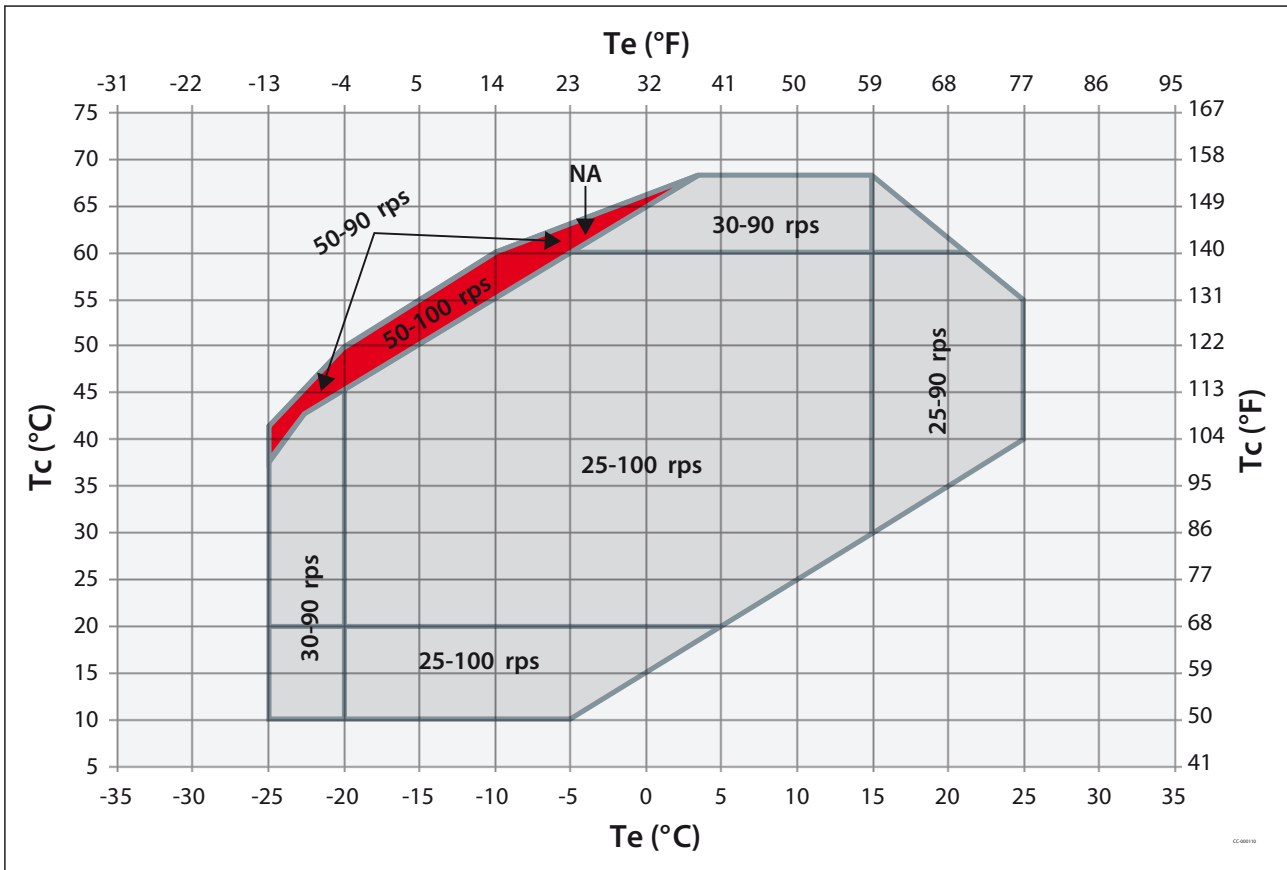

NA Not Allowed

Example 2 with full speed range from 25rps (1500rpm) to 100rps (6000rpm)

Safeties required High-pressure switch, Low pressure switch, Discharge gas thermostat set @135°C (275°F) if necessary see [Discharge temperature protection](#)

Drive setting No parameter change required, keep default value

Envelope control The unit controller continuously measures evaporating and condensing temperatures, as well as maintains compressor speeds according to specific zone restrictions.

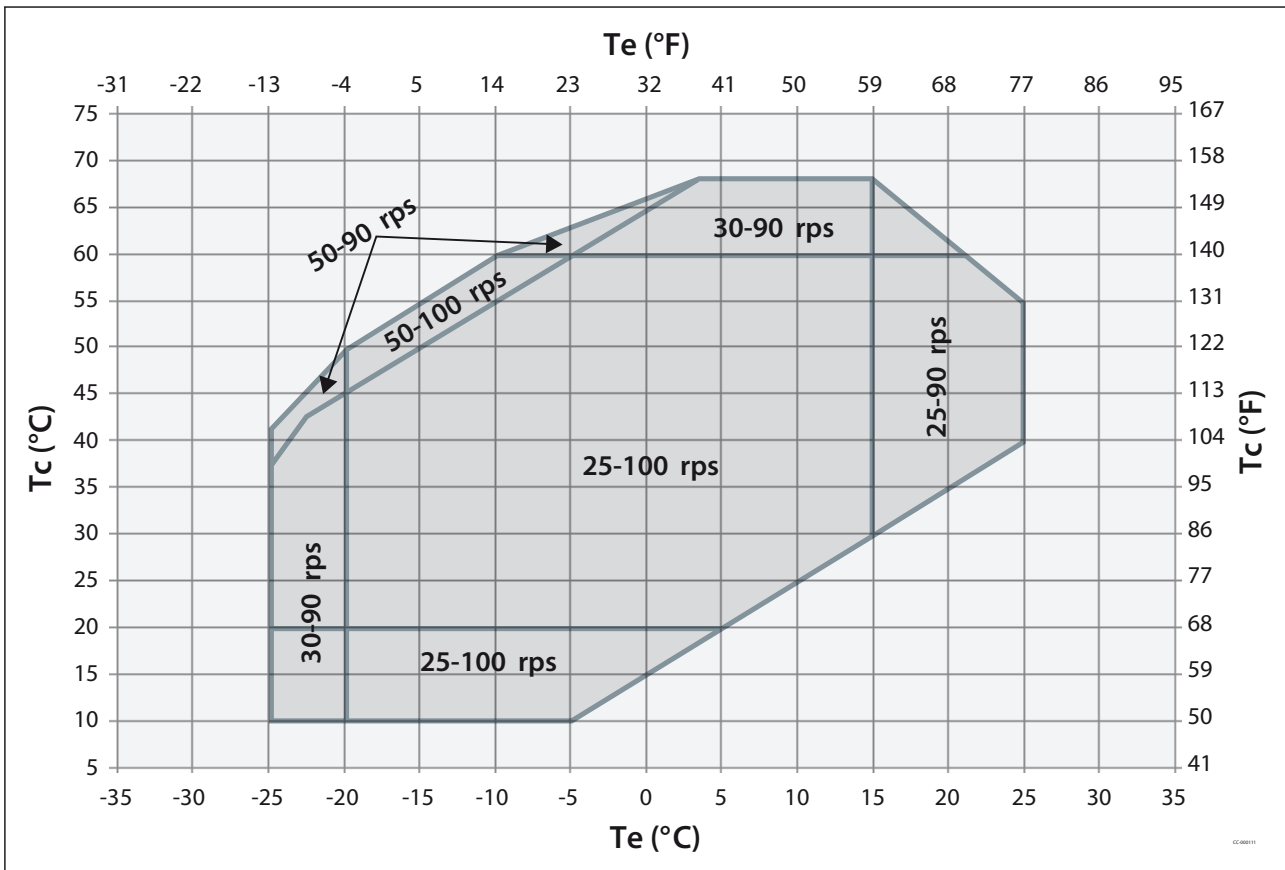

MOP (Max Operating Pressure Control)

⚠ In steady state, it is essential to prevent the compressor running with evaporating temperature higher than the specified envelope. Operation at a higher evaporating temperature may cause compressor damage due to high dilution and low viscosity of lubricant.

This protection can be achieved by using MOP function on expansion device. MOP is a feature of EXV and TXV that limit the maximum suction pressure of the unit. MOP setting must be equal or lower than max evaporating temperature stated in operating envelope.

With variable speed compressors, complementary to MOP of expansion device, the unit controller can increase compressor speed to keep evaporating temperature lower than limit.

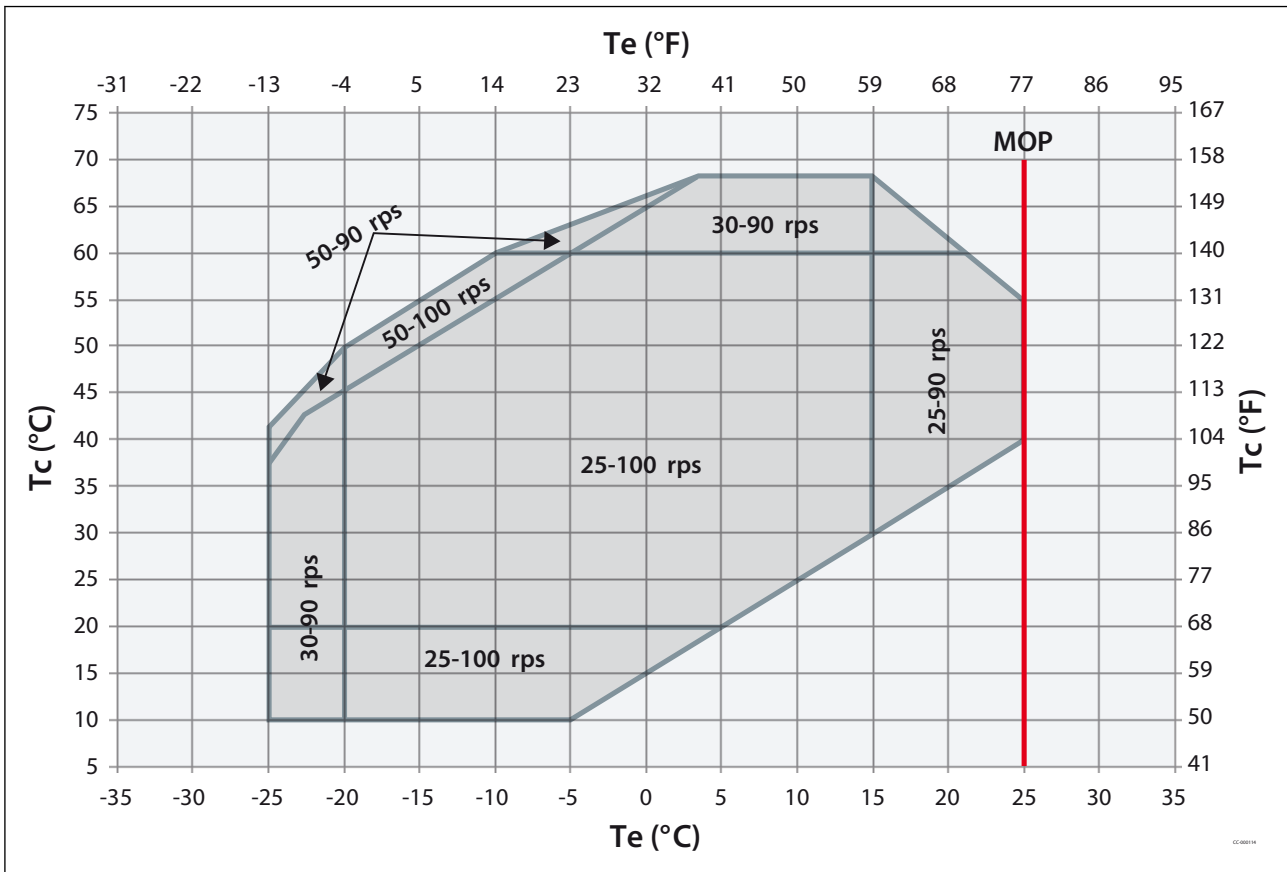

MOP Max Operating Pressure

Manage sound and vibration

Sound level

The sound radiating from the compressor is emitted through the air, the sound waves travel in all directions from the compressor.

We can consider two means to reduce compressors sound radiations: Acoustic hoods are quick and easy to install and do not increase the overall size of the compressors.

Acoustic hoods are available from Danfoss as accessories, in § "Product information" section "sound levels"

The use of sound insulation on the inside of the of the unit panels is an effective way to mitigate sound. You can find sound level and acoustic hood accessories in § "Product information" section "Sound levels"

Vibrations

R Compressor generates some vibrations that propagate into the surrounding parts and structure. The vibration level of a VZH compressor alone does not exceed 127 μm peak to peak. However, when system structure natural frequencies are close to running frequency, vibrations are amplified due to resonance phenomenon. A high vibration level is damageable for piping reliability and generates high sound levels.

To avoid resonance phenomenon, pipings and frame must have natural frequencies as far as possible from running frequencies. This could be challenging on a variable system as all resonant frequencies between min speed to maximum speed will be excited.

It is mandatory to check that piping vibrations are acceptable across speed range. This test can be done by increasing slowly speed and monitoring piping behaviour through, strain gage, acceleration, or displacement measurement. As alternative visual check with strobe light can also emphasis high piping displacement.

If some resonant frequencies generate high piping vibration, problem can be solved by increasing piping stiffness with brackets or changing layout. Dampers can also be installed to mitigate vibration.

If some frequencies continue to produce unacceptable vibration levels, speed by-pass is adjustable in the frequency converter, in order to avoid some frequency ranges. Four by-pass ranges are adjustable, and settings can be made in parameter group 4.6x

Ensure that there is no direct contact between vibrating components and structure.

Gas pulsation

The Danfoss VZH scroll compressor has been designed and tested to ensure that gas pulsation is optimized for the most commonly encountered air conditioning pressure ratio. Manifolder compressors are equivalents to lagged sources of gas pulsation. Therefore, pulse level can vary during time.

If an unacceptable level is identified, a discharge muffler with the appropriate resonant volume and mass can be installed.

Oil return management

Oil injection

An oil injection system is integrated into the VZH compressors for improved sealing of the scroll pockets during compression thus improving its isotropic efficiency while also controlling the amount of oil circulated into the system (oil circulation ratio).

This system is controlled through the frequency converter and preconfigured on relay_1.

The oil injection is ON at low speed and OFF at high speed. The preset speed values are shown on following table

Table 39: Oil injection

Compressor model	Oil injection below
VZH088	65rps 3900rpm
VZH117	55rps 3300rpm
VZH170	45rps 2700rpm

Internally, the solenoid valve is bypassing the oil injection.

Oil injection is ENABLED when solenoid valve coil IS NOT power supplied (Below oil injection speed)

Oil injection is DISABLED when solenoid valve coil IS power supplied (Above oil injection speed)

The compressors are delivered without the coil. They are available in 208-240Vac, 110-120Vac or 24Vac and the ordering code numbers are in the [Ordering](#) section.

Figure 35:

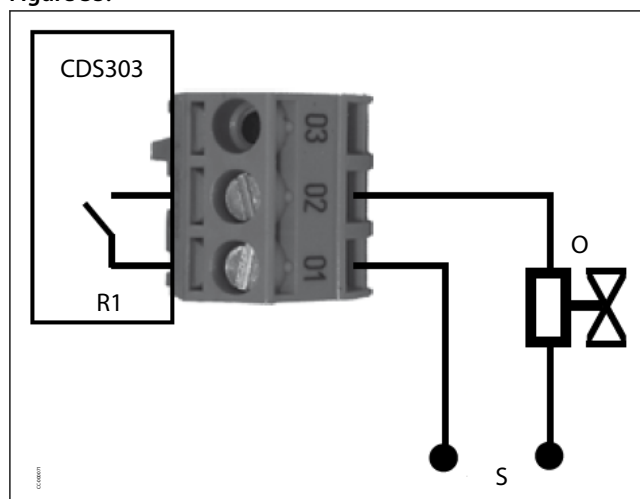

CDS303	Drive
R1	Relay 1
S	Supply voltage to solenoid coil
O	Oil injection solenoid valve

Oil level sensor

A TEKLAB LC-XN optical-electrical level sensor is fixed on the inverter compressor. The oil level sensor prism is fixed on the compressor, the electrical part is ordered by accessory kit. The oil level sensor monitors the compressor oil level and sends oil level signal to an external relay or digital input of unit controller. A 5±2 seconds delay is recommended to mitigate oil level fluctuation and avoid false alarms.

Lack of oil: Circuit between 2 and 3 will be opened internally, there will be no current flowing through load or coil of external relay, relay is open.

Enough oil: Circuit between 2 and 3 will be closed internally, there will be current flowing through load or coil of external relay, relay is close.

NOTE:

For 24VDC, output voltage in case of lack of oil is >13V DC and not 0V

For customers who needs UL certificates, please order 24V AC/DC sensor.

Figure 36: 230VAC Model

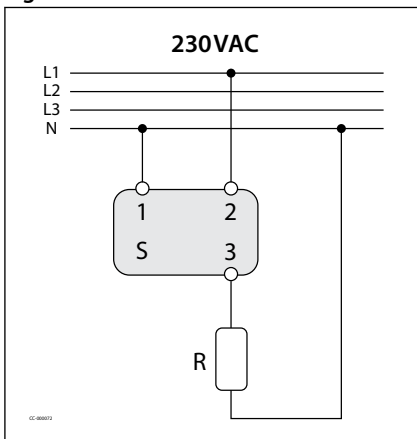

Figure 37: 24VAC Model

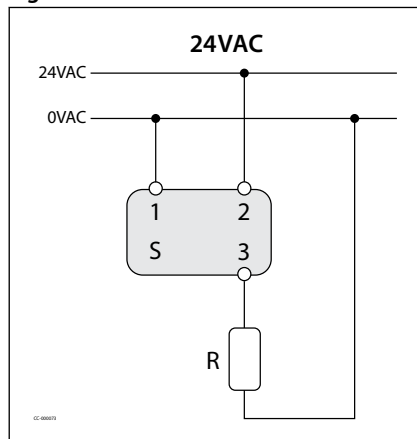
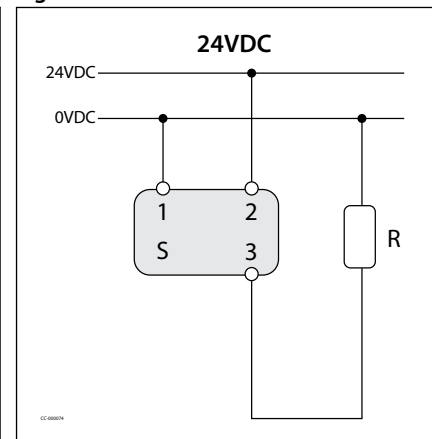

Figure 38: 24VDC Model



S Sensor

R External Load / Relay

Oil level sensor is a special component which assembles on variable speed compressor. It is provided in oil level sensor accessory kit.

Figure 39: Oil level sensor on compressor

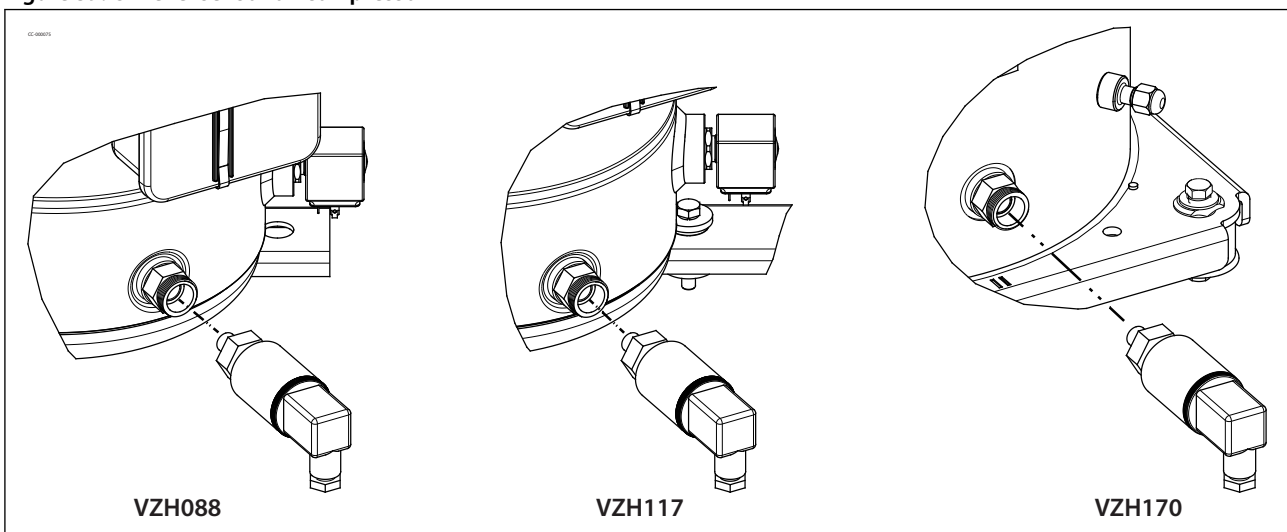

Oil return management

R During operation, compressors always discharge a small amount of oil with refrigerant. After a while, the oil should return to the compressor unless it gets trapped somewhere in the system. When too much oil gets trapped, the compressor may not have enough oil to operate properly.

The main parameters affecting oil return are gas velocity in piping's and exchangers, short cycling control and excessive and fast fluctuation of compressor speed.

Compressors with an oil level sight glass must be visible or full when the compressor is running and when the compressor is stopped. For compressors with an optical level sensor, the sensor will detect low oil levels. The unit controller must follow the oil logic described in **Oil boost**.

Systems with reheat coils, multiple or split evaporator and condensers have a high potential to reduce mass flow and can be susceptible to oil logging. A means to empty or pump out circuitry when not engaged should be implemented to prevent oil logging. Qualification of these units should be done in unfavorable conditions with each feature engaged and disengaged.

Test and components required per application

Table 40: Test and components required per application

Application				Tests and components required			
Basic unit ⁽¹⁾	Ad- vanced unit ⁽²⁾	Non Split ⁽³⁾	Split	Oil separator	Compressor with Optical oil level sensor	Test	Comments
X		X		Optional	Mandatory ⁽⁴⁾	Pass Oil return test	
	X	X		Recommended	Mandatory ⁽⁴⁾	Pass Oil return test	
			X	Mandatory	Optional		In split system, since each installation is unique, tests can not validate the oil return, Oil separator is mandatory. Oil level must be checked and adjusted at commissioning. Pay special attention to "Piping design" on field.

⁽¹⁾ Single exchanger as evaporator and condenser

⁽²⁾ Multiple exchangers as evaporator or condenser (heat-recovery exchanger, roof top reheat coil, four-pipe chiller...)

⁽³⁾ Unit pre charge at OEM factory, no refrigerant piping done on field

⁽⁴⁾ Usage of compressor without optical oil level sensor must be validated by Danfoss application engineer

Oil return test

Table 41: Oil return test

Test conditions	Pass criteria	Comments
Most unfavourable conditions for oil return (lowest refrigerant velocity): lowest evaporating T°, highest condensing T° 1. Compressor at minimum speed 2. VZH088-117 at 50rps (3000rpm) VZH170 at 40rps (2400rpm) For reversible unit, repeat test in both heating and cooling mode For advanced unit (Multiple exchangers roof top reheat coil, four-pipe chiller...) repeat test in all possible configuration	Oil level must be visible or full in the sight glass Compressor with oil level sensor, no oil level sensor trip	If oil return test fails: Increase compressor minimum speed Tops up oil up to 10% of nominal oil charge (Above 10% look for potential oil traps in system) Adjust oil boost logic parameters see § oil management logic

Piping recommendations to ensure oil return

⚠ Oil return is highly linked to refrigerant velocity in piping's. The most unfavorably conditions for oil return are when lowest refrigerant velocity that correspond to lowest evaporating T°, highest condensing T° and minimum compressor speed.

General recommendations are described in the figures below: As variable speed applications have a large speed range, it may be difficult to respect minimum refrigerant velocity in all conditions. To guaranty reliability, it is essential to fully qualify oil return especially in most unfavourable conditions. Take particular care to units with reheat coil or multiple exchangers, as velocity may be further reduced.

Systems with reheat coils, multiple or split evaporator and/or condensers will reduce mass flow further and can be susceptible to oil logging. A means to empty or pump out circuitry when not engaged should be implemented to prevent oil logging. Qualification of these units should be done in unfavorable conditions with each feature engaged and disengaged.

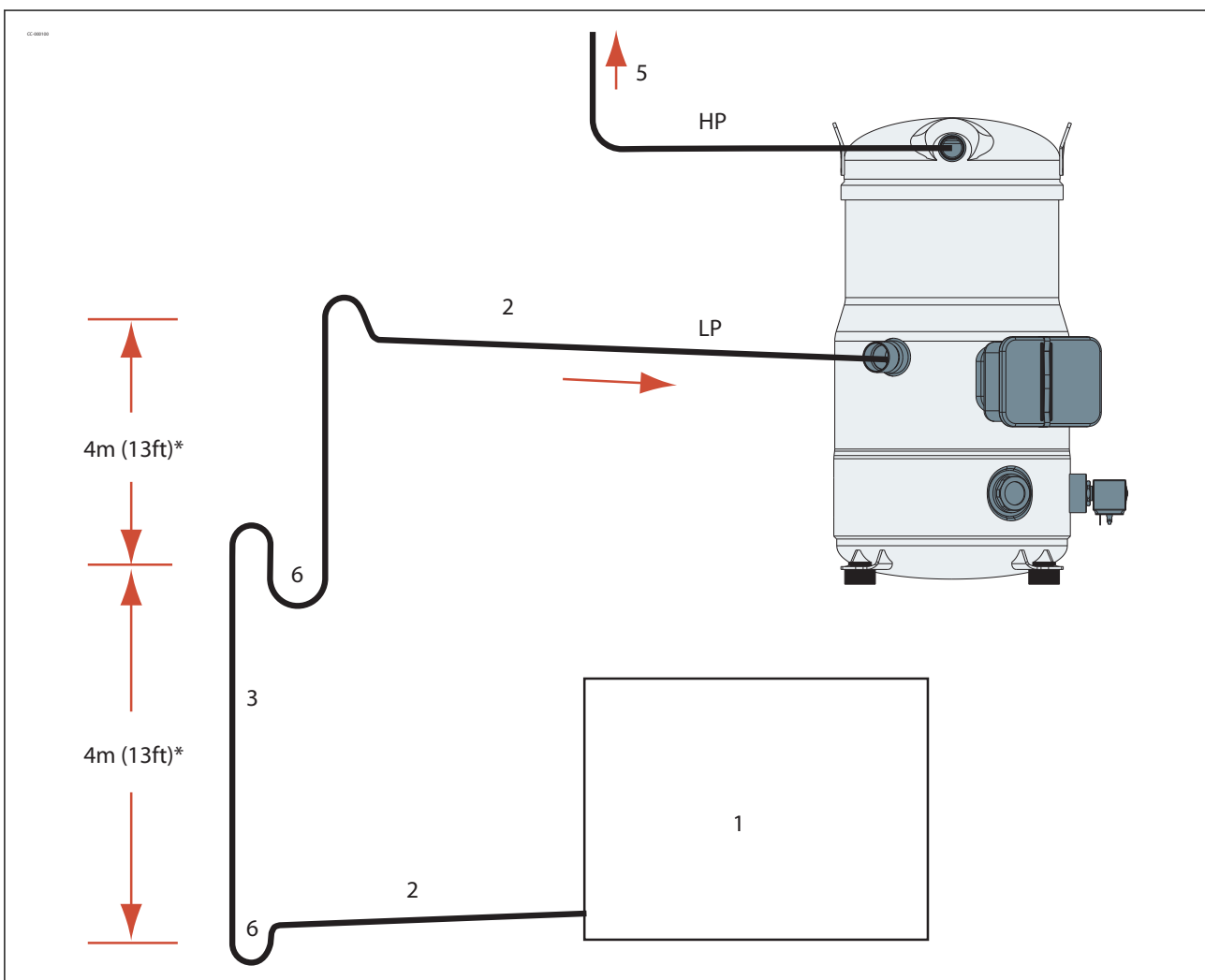

1	Evaporator
2	0.5% slope, 4m/s or more (13ft/s or more)
3	8 to 12m/s (26 to 40ft/s)
4	To condenser
5	U-trap, as short as possible
*	max.

Oil boost

An insufficient oil level can be the result of low refrigerant velocity in pipes and heat exchangers. An oil boost sequence consisting of increasing refrigerant velocity for short periods, at regular time intervals can improve oil return. Oil boost function can be done in 2 ways

1. Using internal CDS drive oil boost function
2. Program oil boost function in unit controller and use optical oil level sensor to trig it.

As oil boost logic needs to increase / decrease speed, make sure expansion device is fast enough to maintain liquid flood back within acceptable limit during those transients (**Manage Superheat**).

CDS Drive oil boost function

If the compressor runs below ORM Min Speed Limit, 28.14) for more than low speed running time, 28-11, then function will override the unit controller and accelerate compressor speed to ORM Boost Speed, 28.16 for Boost duration 28.13 (28.13 does not include the ramping up time). When the boost is finished, the compressor speed goes back to run on reference (speed setpoint) and the time counter is reset and restarting from zero.

On top of that compressor will boost to ORM Boost Speed, 28.16 at a fixed time interval as programmed in parameter 28-12.

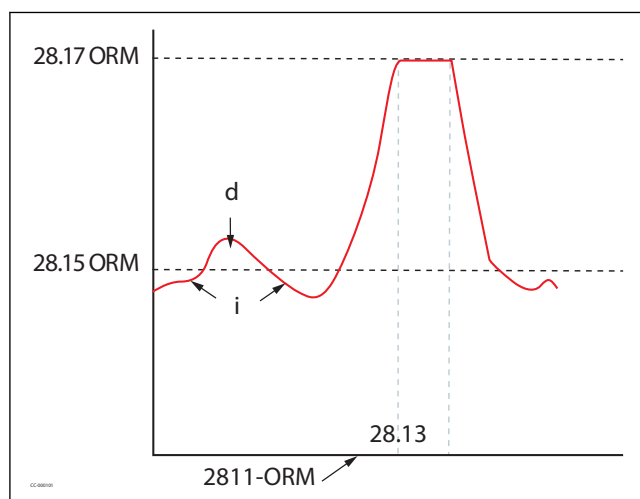

28.17 ORM	28.17 ORM Boost speed
28.15 ORM	28.15 ORM Min speed limit
2811-ORM	2811-ORM Low Speed Running time expire
d	Decrease ORM time
i	Increase ORM time
28.13	Boost duration 28.13

Feedback and status message A feedback signal can be routed back to the unit controller via programmable digital output, relay_2 or Modbus when an oil boost is initiated.

The unit controller can take actions to keep the system stabilized during the oil boost period. A status message "Oil Boost" is also displayed on the drive LCP during boost.

Table 42: Feedback and status message

Drive parameters	Description	value	Default
05-02	Terminal 29 Mode	Output	Input
5-31	Terminal 29 Digital Output	Oil boost active	No Operation
5-40.1	Function Relay	Oil boost active	VLT running
16-94 (read)	Ext. Status Word	1000000hex (bit 24)	

Table 43: Drive parameters

Drive parameters	Description	Default value	Range
"28.10"	Oil return management	Enables/disables Oil Return Management	Enable On / Off
"28.11"	Low speed running	Threshold for boost decision	30min 1-1440min
"28.12"	Fixed boost interval	Maximum time between oil return boosts	6h 1-168h
"28.13"	Boost duration	desired duration of oil boosts	60sec 10-255s
"28.14"	ORM Min speed limit	Now accessible with latest drive software Please update	50rps 3000rpm 1500-4200rpm
"28.16"	ORM boost speed	Now accessible with latest drive software Please update	70rps 4200rpm par. 28-14 - 6000rpm

Oil boost controlled by optical oil level sensor

CDS oil boost function is based on time and compressor speed. More advanced protection can be done using a compressor equipped with an optical oil level sensor and a logic embedded in the unit controller.

Details on optical oil level sensor in §Product information

Table 44: Oil boost controlled by optical oil level sensor

Drive parameters	Description	Default value
"28.17"	Oil return management	Disable (managed by unit controller)
		Enable

Figure 40: Oil boost controlled by optical oil level sensor

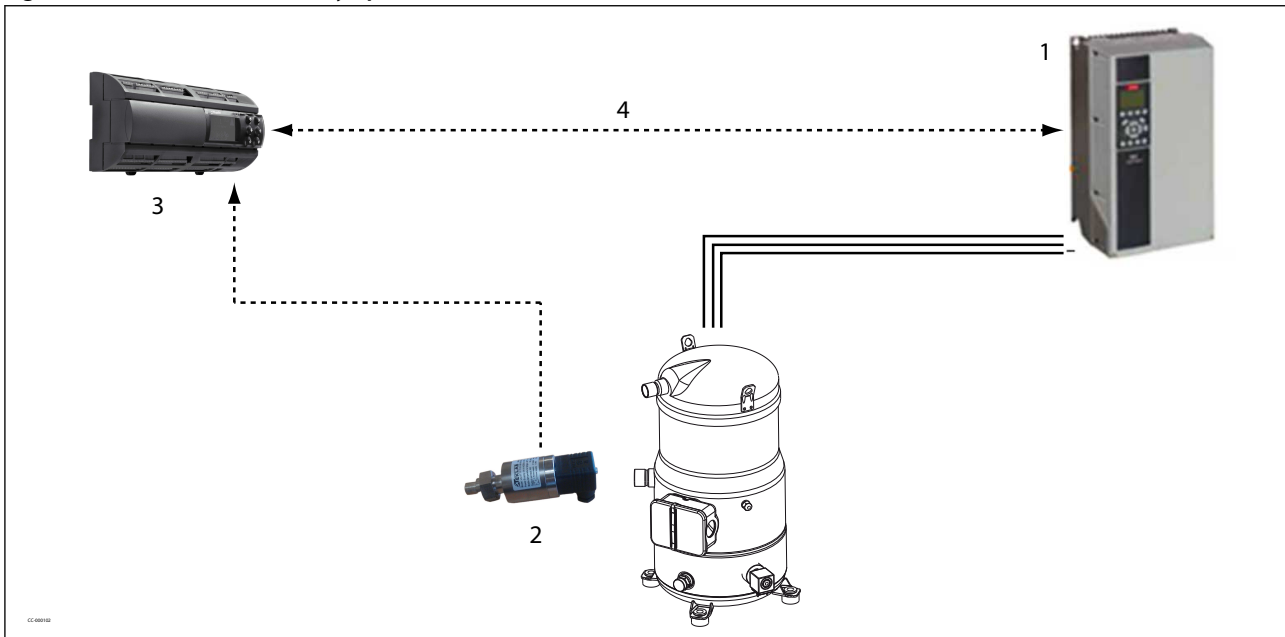

1	Drive	3	Oil management logic embedded in unit controller
2	Optical oil level sensor	4	ModBus

The oil management control logic must include 2 steps.

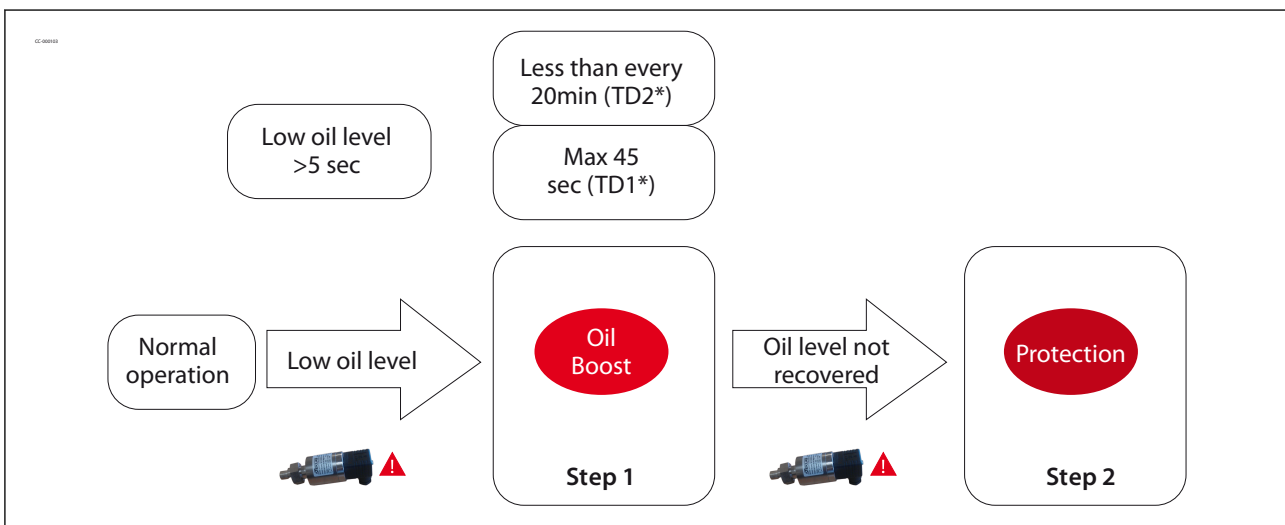

Step 1 (oil boost) If oil level sensor detects low level for more than 5 seconds, oil is trapped in the system. Oil boost is activated (VS speed is increased). It increases refrigerant velocity in the system and recovers oil. **TD1** is the maximum time to complete step 1. If oil is not recovered within TD1 switch to step 2. If oil is recovered within TD1, the compressor will come back to normal operation.

TD2 is the minimum interval between two step 1. In case of low oil level detection within a time $<TD2$, switch to step 1.

Step 2 (Protection) If the oil is still lower than the limit after having completed step 1, or if the oil level drips again within a time $<TD2$, the controller must move forward in protection mode and stop the system in alarm.

Step 1 Oil boost Function description

Return oil trapped in the system to compressor by increasing refrigerant mass-flow in the system.

Enter condition: Low oil level in VS compressor detected by oil level sensor.

Cancel condition: High oil level in VS compressor detected by oil level sensor.

OR

$t1 > TD1$, Oil boost duration exceeds Maximum Oil boost duration

Control sequence:

1. At initial state, VS (variable speed compressor) is ON.
2. Low oil level detected in compressor. Reset and Start $t1$.
3. VS compressor speed must increase to F_{boost}
4. When High oil level detected in VS compressor speed must be decreased to the initial speed
 - Reset and start $t2$
 - Reset $t1$

Figure 41: Step 1 Oil boost Function description

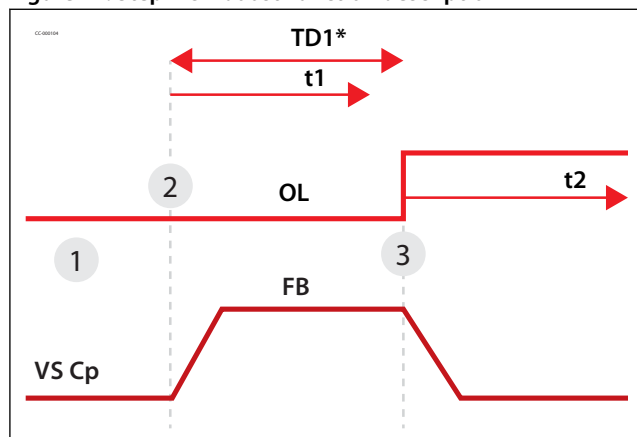

VS Cp	variable speed compressor
FB	F_{Boost}
OL	Oil lack
TD1*	TD1 Max.

Step 2 Protection Function description

Stop the compressor to prevent short of oil running.

Enter condition: Low oil level in VS compressor detected by oil level sensor.

AND

$(t1 > TD1, \text{ Oil boost duration exceeds } TD1 \text{ OR } t2 < TD2, \text{ Interval between two Oil boost is } < TD2)$

Cancel condition: Manual Reset

Control sequence: Stop VS compressor

- Reset $t1$
- Reset $t2$

Oil separator

Oil separator removes oil from the compressor's discharge gas, and return it to the compressor's crankcase. Oil separators are located close to the compressor in the discharge line.

In split systems, since each installation is unique, tests cannot validate the oil return, therefore an oil separator is mandatory.

Floating valve oil separators are the easiest to implement in the system. Oil return connection must be done on the suction line after suction pressure and temperature sensors have been used for superheat control.

The outlet of the oil separator must be equipped with a non-return valve in order to prevent liquid refrigerant from migrating back from the condenser.

To avoid having the oil separator act as a condenser, do not place it in the airflow or oversize it. If airflow is unavoidable, the oil separator must be insulated.

Some separators require an initial oil charge to float the needle valve float.

For installation and dimensioning, always follow manufacturer recommendations

Figure 42: Oil separator

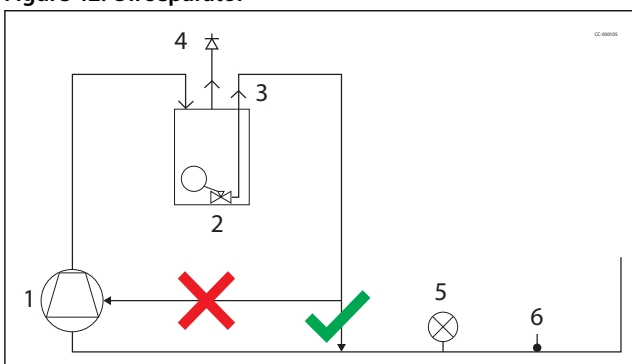

1	Compressor
2	Oil separator
3	Oil return
4	Non return valve
5	Pressure sensor
6	Temperature sensor

Manage Superheat

⚠ During normal operation, refrigerant enters the compressor as a superheated vapor. Liquid flood back occurs when some refrigerant returns to the compressor in a liquid state. Liquid flood back can cause oil dilution and, in extreme situations, lead to liquid slugging that can damage the compressor.

In steady state conditions, suction superheat must be maintained within 5K to 30K (9 to 54°F) and oil superheat must be higher than 7K (12.6°F). In transient conditions, oil superheat below 7K (12.6°F) must not last more than 60s per event. Note: oil superheat criterion is mainly used during qualification to confirm liquid flood back is acceptable. It is not mandatory to monitor it on production unit.

Oil superheat measurement during qualification

Figure 43: Dilution chart (reference at 20°C / 68°F ambient temperature)

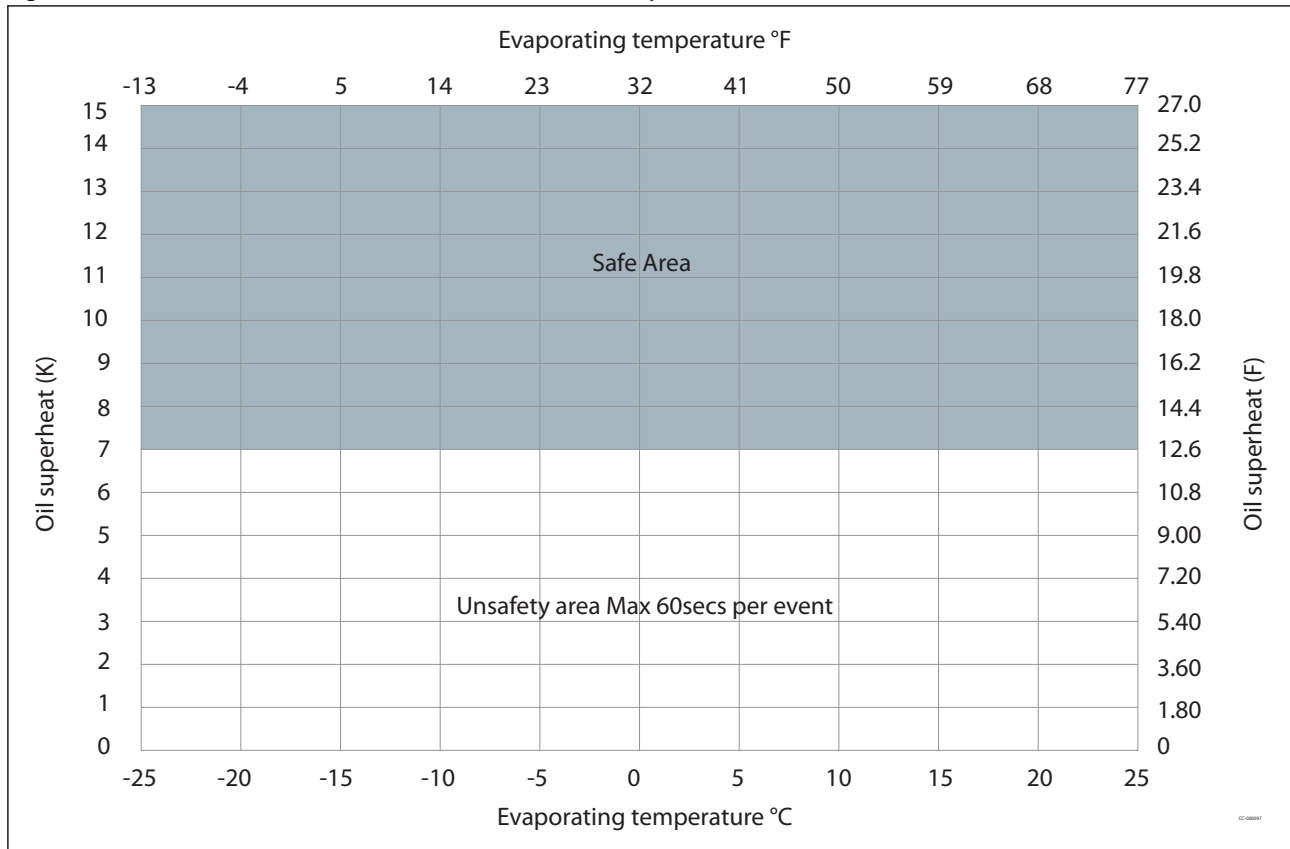

Placing oil temperature sensor

Oil temperature sensor must be placed between oil sight glass and compressor baseplate. Some thermal paste shall be used to improve the conductivity. The sensor must also be correctly thermally insulated from the ambience.

The Oil superheat is defined as: $(\text{Oil temperature} - \text{Evaporating temperature})$

Figure 44: Placing oil temperature sensor

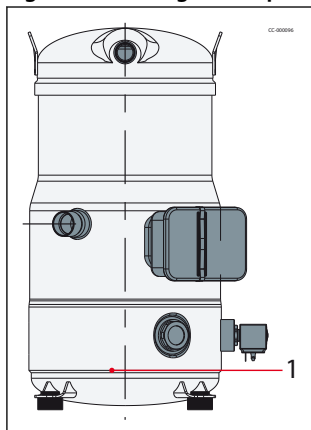

- 1 Oil temperature sensor must be placed between oil sight glass and compressor baseplate.

Test and components required per application

Table 45: Define tests and components required for your application

Application		Tests and components required		
Non Reversible	Reversible ⁽¹⁾	Suction accumulator	Test	Comments
X		Optional	Pass liquid floodback test	If no test performed, suction accumulator is mandatory
	X	Recommended	Pass liquid floodback test Pass defrost test	

⁽¹⁾ Unit equipped with a 4-way valve.

Liquid floodback and defrost test

Table 46: Liquid floodback and defrost test

Test	Test conditions	Pass criteria	Comments
Liquid flood back test	<p>1. Steady state Most unfavourable conditions for superheat control (expansion valve threshold): Lowest evaporating T°, highest condensing T°, compressor at minimum speed For reversible unit, repeat test in both heating and cooling mode For advanced unit (Multiple exchangers roof top reheat coil, four-pipe chiller...) repeat test in all possible configuration</p> <p>2. Transient Test must be carried out with most common transient such: Compressor starts Fan staging Compressor speed ramp up and ramp down from min speed to max speed</p>	<p>Suction superheat >5K (9°F) and stable Oil superheat above 7K (12.6°F)</p> <p>Oil superheat must not be more than 60 sec below 7K (12.6°F)</p>	<p>If test fails, check expansion valve selection and setting For thermostatic expansion valve (TXV) check bulb position For electronic expansion valve (EXV) check measurement location and PID parameter and valve prepositioning if any Add suction accumulator Increase ramp-up and ramp down time to slow down compressor speed change Increase minimum speed</p>
Defrost cycle	Defrost test must be carried out in the most unfavourable conditions (~ 0°C 32°F ambient conditions)	After defrost, Oil superheat must not be more than 60 sec below 7K (12.6°F)	<p>Check defrost logic. 4 Way valve control and defrost logic Add suction accumulator</p>

Expansion valve

R Role of expansion device is to open and close to maintain a proper superheat at outlet of evaporator (s)

- Electronic expansion device (EXV) is preferred to thermostatic expansion device (TXV) as it has a better ability to control superheat at low load.
- It is essential that valve closes when compressor stops.
- For TXV, liquid line solenoid valve is strongly recommended, and if not possible, suction accumulator can be used as an alternative.
- Bleed type valve is not accepted.
- For EXV, controller must be programmed to close it when the compressor stops, including in power shut down situation.
- See **MOP (Max Operating Pressure Control)** in **Manage Operating envelope**.

Selection of expansion valve

Valve selection must ensure that load of the valve (Compressor capacity/Nominal valve Capacity) is within acceptable range across normal running condition of unit.

As a rule of thumb, load must be within 10% to 120% for EXV and within 30% to 120% for TXV.

To define max load and min load of the valve, the first step is to define in which area of compressor envelope the unit will be used in normal operation.

The lowest load happens at lowest speed of compressor, minimum evaporating Temperature, Max condensing Temperature ①

The highest load happens at highest speed of compressor, maximum evaporating Temperature, Max condensing Temperature ②

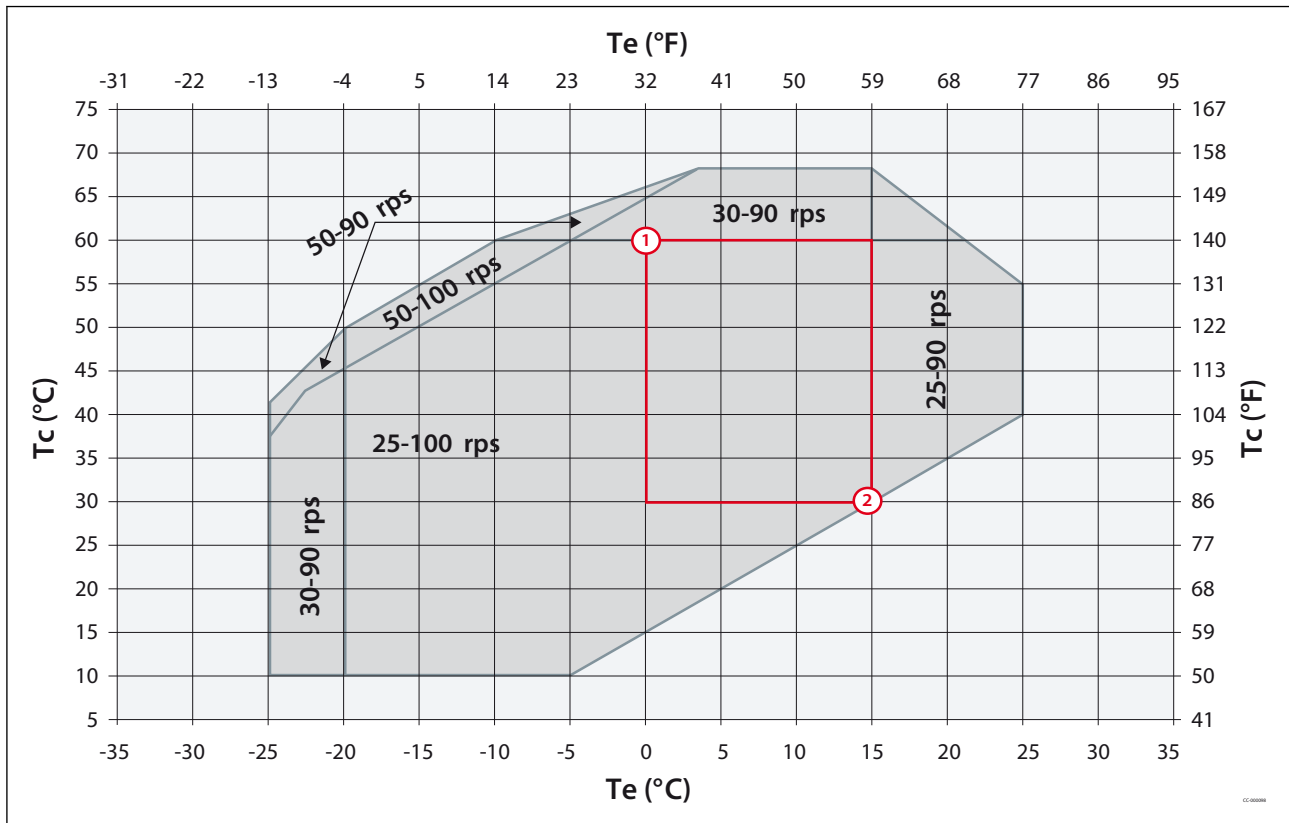

- ① Lowest expansion valve load with lowest compressor speed
- ② Highest expansion valve load with highest compressor speed

Adjustment of EXV control parameters

⚠ To have a proper superheat regulation with EXV, regulation parameters especially speed reaction must be tested and adjusted. In variable speed load is permanently changing and valve must be fast enough to handle compressor speed changes. It is common practice to have a slow reaction to maintain a stable superheat. This was acceptable in fixed speeds, as loads do not change. The use of prepositioning function usually indicates that the valve is not fast enough to handle any changes in speed.

Figure 45: EXV control parameters

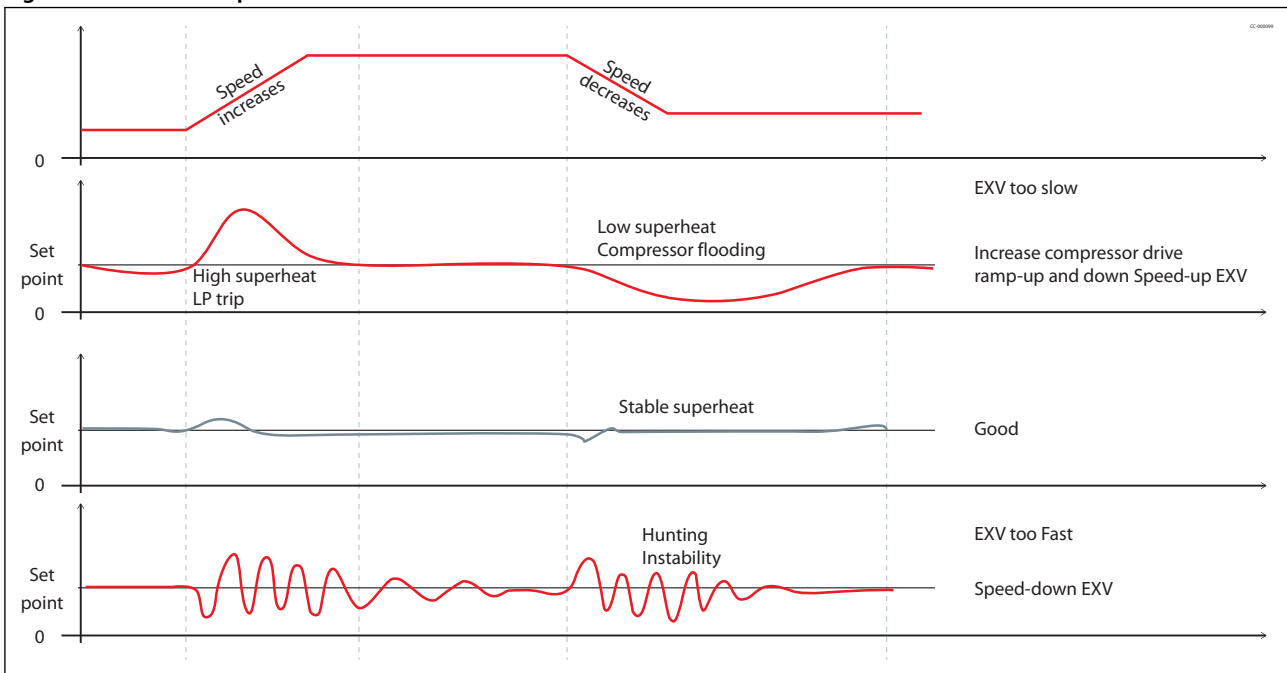

Location and installation of bulb (txv) or pressure and temperature sensor (EXV)

⚠ Good suction temperatures and pressures are essential to guaranty proper superheat control.

Suction pressure and temperature must be taken at the same location site carefully to avoid any potential ambient temperature influence. For non-reversible units, the superheat measurement must be taken as close as possible from the evaporator (as it leaves) and within the evaporator enclosure. For reversible systems, the measurements must be done after the 4-way valve.

It is important to keep temperature measurements at a minimum piping distance of 30cm (12in) from any large mass components, such as 4-way valves, compressors, suction accumulators or pressure relief valves.

If suction accumulator is used measurement must be done upstream of it.

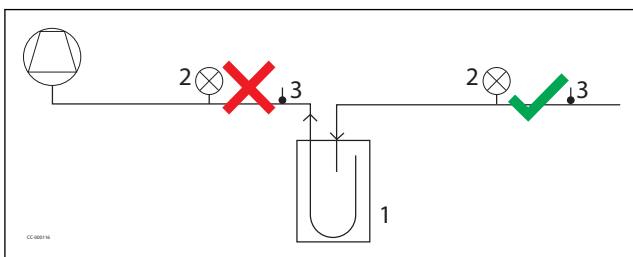

- | | |
|---|---------------------|
| 1 | Suction accumulator |
| 2 | Pressure sensor |
| 3 | temperature sensor |

If suction oil separator measurement must be done upstream of it.

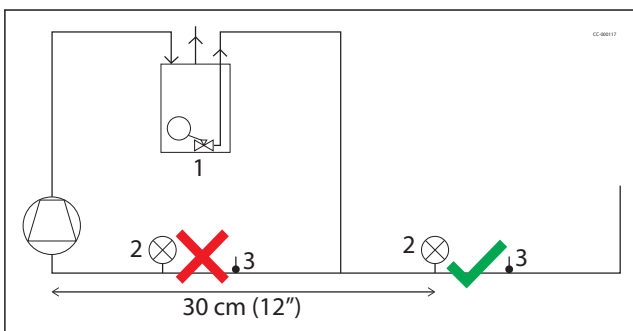

- | | |
|---|--------------------|
| 1 | Oil separator |
| 2 | Pressure sensor |
| 3 | temperature sensor |

Suction accumulator

⚠ The role of suction accumulators is to collect any excess liquid that may come out of the evaporator during the transient period or low load conditions.

See §Test and components required per application in §Superheat management to know when to use suction accumulator.

Suction accumulator sizing must be made according to its manufacturer recommendation. Liquid capacity must be above 50% of system charge. To not penalize too much energy efficiency, the pressure drop generated by accumulator should be below 2°C evaporating temperature.

To prevent oil from getting trapped in the bottom of the suction accumulator, the suction line inside the accumulator (U shape) has a small orifice to drain the collected oil.

The superheat measurement must be done before suction accumulator.

Figure 46: Suction accumulator

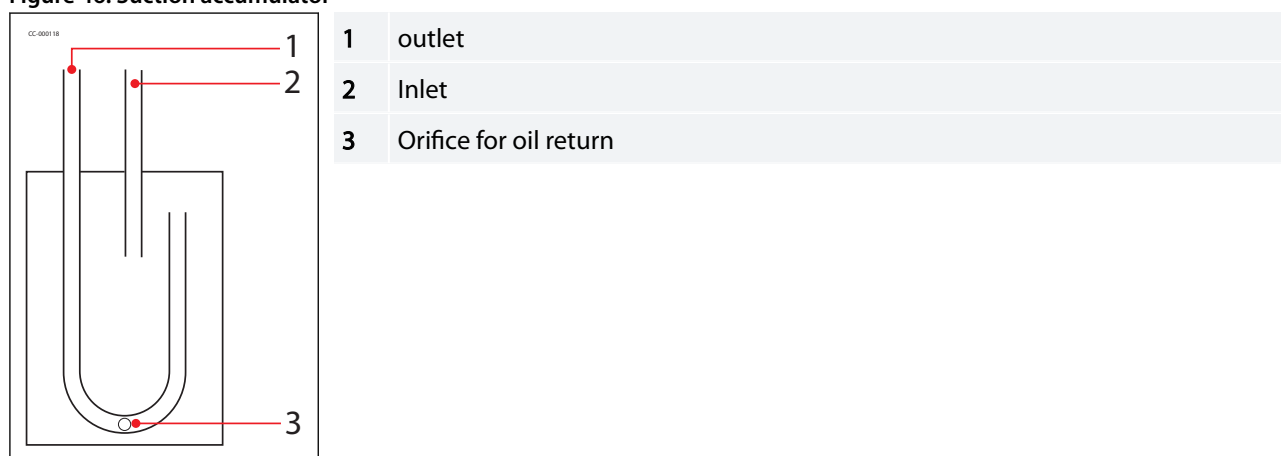

Manage off cycle migration

General information

⚠ Off-cycle refrigerant migration happens:

- When the compressor is located at the coldest part of the installation, refrigerant vapour condenses in the compressor.
- Directly in liquid-phase by gravity or pressure difference.
- Refrigerant migrates to evaporator during off cycle

Poor lubrication when a compressor starts can reduce compressor bearing life. The oil can be diluted by liquid refrigerant that migrates to the crankcase in the off-cycle, or liquid refrigerant stored in evaporator slugging the compressor when it first re-starts. In extreme situations, this leads to liquid slugging that can damage the compressor scroll set.

Compressor charge limit

If the charge limit is exceeded, protective measures must be taken to limit the risk of liquid slugging and extreme dilution at start.

Table 47: Compressor charge limit

Compressor model	Refrigerant charge limit	
	Kg	lb
VZH088	6	13
VZH117	8	18
VZH170	13	29

Test and components required per application

Table 48: Test and components required per application

Application				Components required			
Non Split ⁽¹⁾	Split	Below charge limit	Above charge limit	Surface sump heater	Non return valve	Pump down cycle	Comments
X		X		Recommended	Mandatory for unit with water condenser (W/W or reversible A/C Chiller)	Optional	Ensure tightness between condenser & evaporator when system is OFF • If thermostatic expansion valve (TXV): Liquid line solenoid valve LLSV strongly recommended, if not possible Suction accumulator can be used as an alternative Bleed type valve not accepted • If electronic expansion valve (EXV): must close when the system stops, including in power shut down situation or power loss
X			X	Mandatory	Mandatory	Optional	
	X			Mandatory	Mandatory	Recommended	

⁽¹⁾ Unit pre charge at OEM factory, no refrigerant piping done on field

⚠ To avoid condensed liquid refrigerant from draining back when the compressor is shut off, the condenser outlet must have an “upper loop” shape.

Figure 47: Avoid condensed liquid refrigerant from draining back

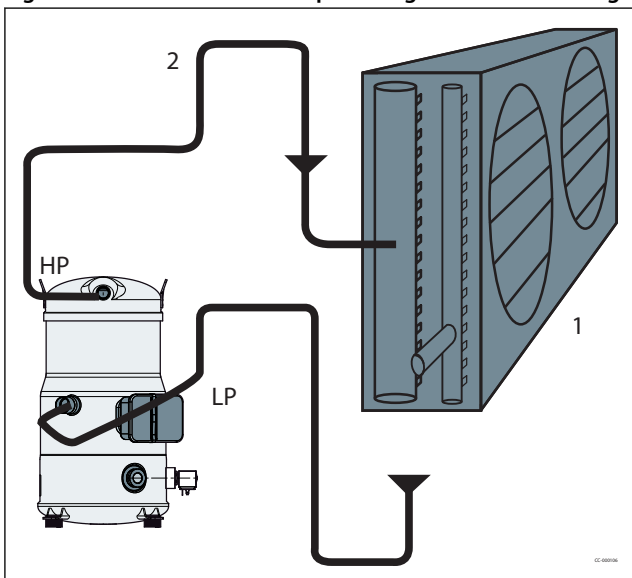

- | | |
|---|------------|
| 1 | Condenser |
| 2 | Upper loop |

Surface sump heater

⚠ When the unit idles, refrigerant migrates to the coldest point of the system. Sump heater are designed to avoid compressor becoming the coldest point of system and accumulate refrigerant in sump.

See [Test and components required per application](#) to know when to use heater Surface sump heater accessories are available from Danfoss (see section [Accessories and Spare parts](#)).

Figure 48: Surface sump heater for VZH088-117

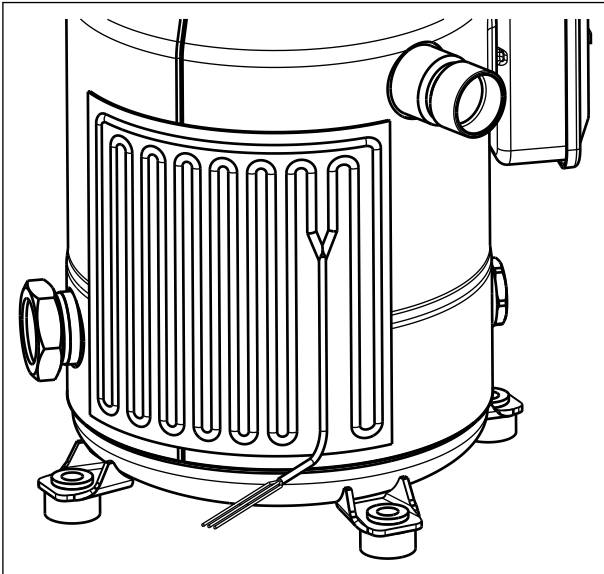

For VZH088-117, the surface sump heater should be mounted on the compressor shell. For better standby energy consumption, Danfoss provides 48W and 80W surface sump heater. The selection shall be done according to following table:

Compressor Surrounding Ambient	Surface Sump Heater
Unit has enclosure, no wind	48W SSH
Unit has no enclosure, with wind	80W SSH
Unit has no enclosure, wind >5m/s (ft/s)& ambient temperature <-5°C	80W SSH + additional SSH/thermal insulation

Figure 49: Surface sump heater for VZH170

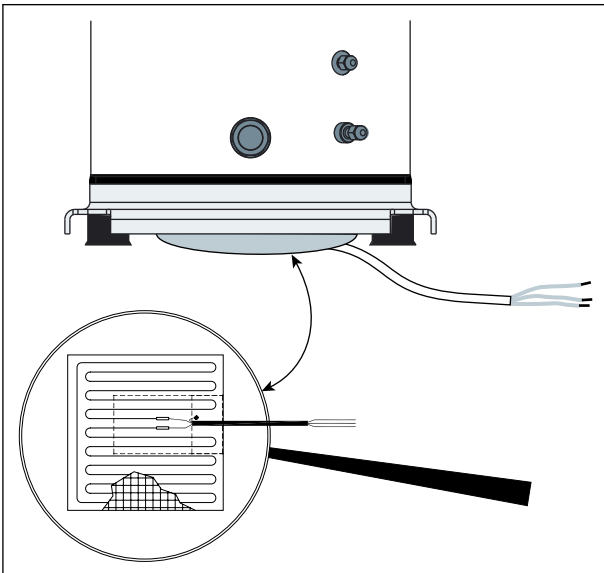

For VZH170, the 56W surface sump heater should be mounted below the sump, associated with a thermal insulation.

Surface sump heater control logic

⚠ The heater is typically controlled by a unit controller and shall be ON whenever all compressors within the circuit are OFF.

For units that may be totally power shut down on a regular basis, such as exhibition hall, it is strongly recommended to the heater to a secured power supply in order to maintain migration protection.

At commissioning, the surface sump heater must be energized at least 6 hours in advance to remove refrigerant from sump.

To optimize energy efficiency of heater, oil sump temperature can be permanently monitored by the unit controller, and the heater can be turned off when oil superheat (oil temperature – evaporating temperature) is above 7K (12.6°F).

To further protect against flooded starts, a logic can be programmed in the unit controller. After each unit power up, the compressor only can start if the oil super heat is above 7K (12.6°F). More details regarding the oil sump temperature measurement can be found in section **Manage Superheat** “Oil superheat measurement during qualification”.

Non return valve

R Non-return valve at discharge prevents from liquid or gas migration. Selection of non-return valve is a trade-off between pressure dropping at high speed, and the state of the valve stability while at low speed.

See Section Prevent off cycle migration §Test and components required per application to know when to use non return valve

The following table displays present Danfoss non-return valve selection per each specific compressor.

Table 49:

Compressor model	NRV model
VZH088	NRV 16
VZH117	NRV 19
VZH170	NRV 22

Liquid line solenoid valve (LLSV)

A Liquid line solenoid valve (LLSV) is used to isolate the liquid charge on the condenser side, thereby preventing against charge transfer to the compressor during off -cycles. The quantity of refrigerant on the low-pressure side of the system can be further reduced by using a pump-down cycle in association with the LLSV.

Pump down cycle

By decreasing pressure in the sump, pump down system:

- evacuates refrigerant from oil
- set the sump saturating pressure much lower than ambient temperature and due to that, avoid refrigerant condensation in the compressor.

Pump down cut-out pressure setting shall be 1.5 bars (21psi) below nominal evaporating pressure with a minimum of 2.3bars (g) (33psig).

Pump down shall be done at low compressor speed to reduce high or low-pressure tripping risk.

Pump down cycle logic

Pump down is initiated prior to shutting down the last compressor on the circuit by de-energizing a liquid line solenoid valve or closing electronic expansion valve. When suction pressure reaches the cut-out pressure, the compressor is stopped, and the liquid solenoid valve or electronic expansion valve remains closed. Two types of pump-down exist:

- “One shot pump down” (preferred): when the last compressor of the circuit stops, suction pressure is decreased down to cut-out pressure. Even if suction pressure increases again, the compressor will not restart.
- “Continuous pump-down”: similar to “One shot pump down” but compressor restarts automatically when suction pressure increases. In that case a non-return valve at the discharge line is mandatory.

Assembly line procedure

Reduce moisture in the system

Excessive air and moisture

- can increase condensing pressure and cause high discharge temperatures.
- can create acid giving rise to copper plating.
- can destroy the lubricating properties of the oil.

All these phenomena can reduce service life and cause mechanical and electrical compressor failure.

Requirements

VZH compressors are delivered with < 100 ppm moisture level. At the time of commissioning, system moisture content may be up to 100 ppm.

During operation, the filter drier must reduce this to a level between 20 and 50 ppm.

Solutions

To achieve this requirement, a properly sized and type of drier is required. Important selection criteria's include:

- driers water content capacity,
- system refrigeration capacity,
- system refrigerant charge.

For new installations with VZH compressors with POE oil, Danfoss recommends using the Danfoss DML (100% molecular sieve) solid core filter drier.

Compressor storage

Store the compressor in a manner that it is not corrosive or flammable atmosphere between -35°C to 70°C (-31°F to 158°F) when charged with nitrogen and between -35°C (-31°F) and Ts max value (see section [Pressure equipment directive 2014/68/EU](#)) when charged with R410A refrigerant.

Compressor holding charge

Each compressor is shipped with a nominal dry nitrogen holding charge between 0.3 and 0.7 bar (4 psi and 10psi) and is sealed with elastomer plugs.

Respect the following sequence:

- Remove the nitrogen holding charge via the suction Schrader valve to avoid an oil mist blow out.
- Remove the suction plug first and the discharge plug afterwards to avoid discharge check valve gets stuck in open position.

An opened compressor must not be exposed to air for more than 20 minutes to avoid moisture is captured by the POE oil.

Handling

- Use lifting equipment rated and certified for the weight of the compressor or compressor assembly.
- A spreader bar rated for the weight of the compressor is highly recommended to ensure a better load distribution.
- The use of lifting hooks closed with a clasp is recommended.
- Never use the lift rings on the compressor to lift the full unit.

Maintain the compressor in an upright position during all handling manoeuvres (maximum of 15° from vertical).

Figure 50: Heavy do not lift manually



Figure 51: handle with Spreader bar

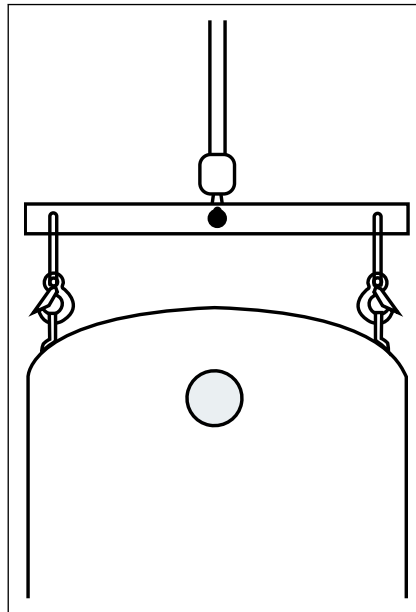
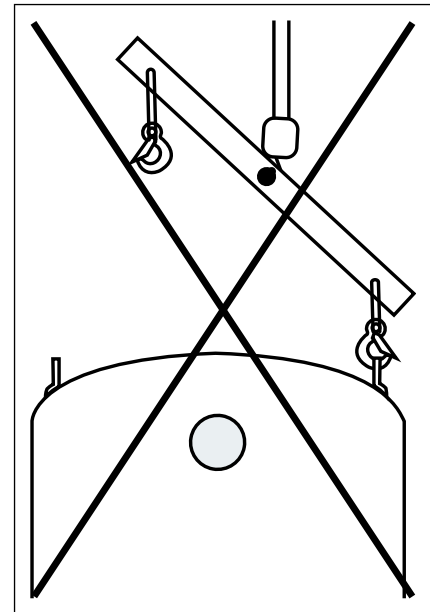

Figure 52: incorrect handling



Piping assembly

Good practices for piping assembly is a pre-requisite to ensure compressor life time (system cleanliness, brazing procedure etc.)

Table 50: System cleanliness

Circuit contamination possible cause:	Requirement:
Brazing and welding oxides	During brazing, flow nitrogen through the system.
Filings and particles from the removal of burrs in pipe-work	Remove any particles and burrs generated by tube cutting and hole drilling.
Moisture and air	Use only clean and dehydrated refrigeration grade copper tubing. Opened compressor must not be exposed to air more than 20 minutes to avoid moisture captured by PVE oil.

Brazing procedure:

- Brazing operations must be performed by qualified personnel.
- Make sure that no electrical wiring is connected to the compressor.
- To prevent compressor shell and electrical box overheating, use a heat shield and/or a heat-absorbent compound.
- Clean up connections with degreasing agent
- Flow nitrogen through the compressor.
- Use flux in paste or flux coated brazing rod.
- Use brazing rod with a minimum of 5% silver content.
- It is recommended to use double-tipped torch using acetylene to ensure a uniform heating of connection.
- To enhance the resistance to rust, a varnish on the connection is recommended.

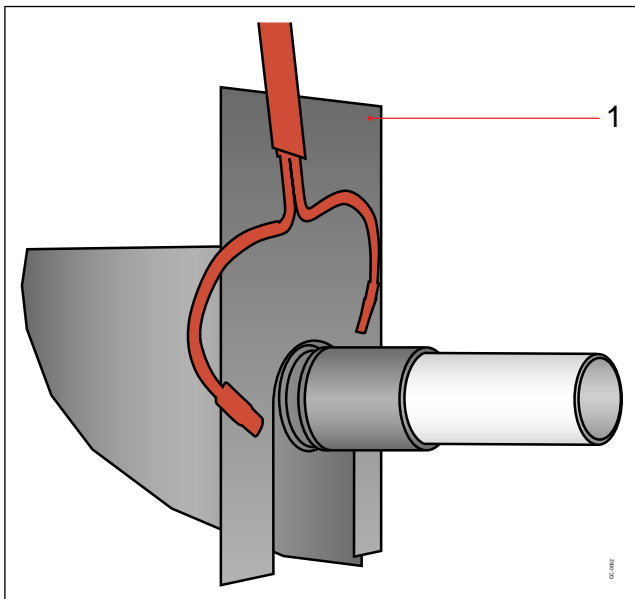

1 Heat shield

⚠ Before eventual un-brazing of the compressor or any system component, the refrigerant charge must be removed.

System pressure test and leak detection

⚠ The compressor has been strength tested and leak proof tested (<3g/year) at the factory. For system tests:

- Always use an inert gas such as Nitrogen or Helium.
- Pressurize the system on HP side first then LP side.
- Do not exceed the following pressures indicated in table below

Table 51: Maximum compressor test pressures

Maximum compressor test pressures	
Maximum compressor test pressure high side (HP)	48.7 bar(g)(706psig) HP-LP<37bar (537psi)
Maximum compressor test pressure low side (LP)	33.3 bar(g) / (483psig) for VZH088 & 117 30.2 bar(g) / (438psig) for VZH170 LP-HP<5bar (73psi) Maximum speed 4,8 bar/second (70psi/s) ⁽¹⁾

⁽¹⁾ If an external non return valve is present on the discharge line, maximum pressurizing speed must be respected to ensure pressure equalization between LP and HP side over scroll elements.

Vacuum evacuation and moisture removal

⚠ Requirements:

- Never use the compressor to evacuate the system.
- Connect a vacuum pump to both the LP and HP sides.
- Evacuate the system to a pressure of 500 µm Hg (0.67 mbar/0.02 in.Hg) absolute.

Recommendations:

- Energized heaters improve moisture removal.
- Alternate vacuum phases and break vacuum with Nitrogen to improve moisture removal.

For more detailed information see “Vacuum pump-down and dehydration procedure” TI-026-0302.

Refrigerant charging

⚠ Initial charge:

- For the initial charge, the compressor must not run.
- Charge refrigerant as close as possible to the nominal system charge.
- This initial charging operation must be done in liquid phase between the condenser outlet and the filter drier.

If needed, a complement of charge can be done, in liquid phase while compressor is running by slowly throttling liquid in.

Never bypass safety low pressure switch.

For more detailed information see “Recommended refrigerant system charging practice” [AP000086421422](#).

Dielectric strength and insulation resistance tests

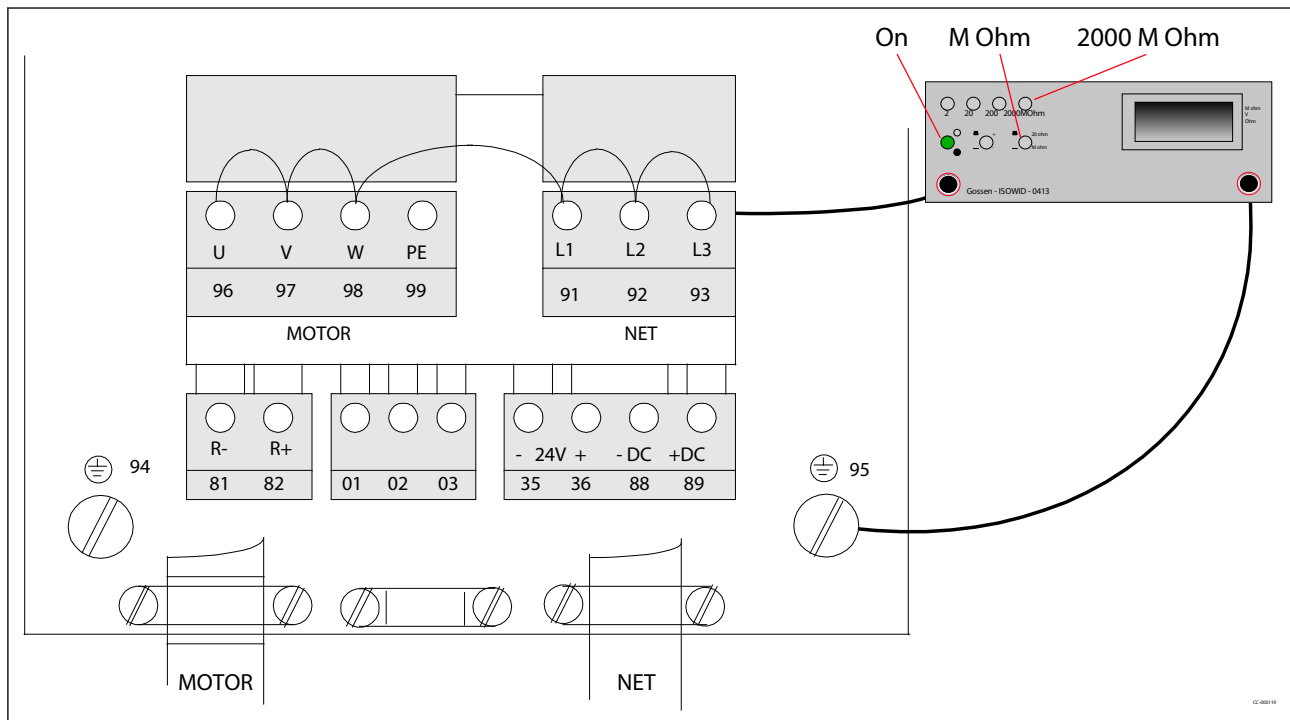

It is not necessary to perform a Hipot test (dielectric withstand test) on frequency converters. This has already been done during factory final test.

If a Hipot test has to be done anyway, following instructions must be followed in order to not damage the frequency converter:

- Compressor not connected
- L1, L2, L3, U, V, W terminals must be shorted and connected to high voltage terminal of the testing device.
- Ground terminal (chassis) must be connected to low voltage terminal of the testing device.
- 2000VDC(for T2)/2150VDC(for T4)/2250VDC(for T6) for 1 seconds must be applied
- Ramp up time 3 seconds
- Full DC voltage must be established during 2 seconds
- The current leakage during the test must be below 1mA
- Ramp down time to 0V in 25 seconds. When running high voltage tests of the entire installation, frequency converter and compressor electrical motor compressor test can be conducted together. When conducting a high voltage test make sure the system is not under vacuum: this may cause electrical motor compressor failure.

⚠ Do not use a megohm meter nor apply power to the compressor while it is under vacuum as this may cause internal damage.

Commissioning

Preliminary check

⚠ Check electrical power supply:

- Phase order: Reverse rotation is obvious if the compressor does not build up pressure and sound level is abnormal high. VZH compressor will only operate properly in one direction. If electrical connections are done correctly between the drive and the compressor terminals (compressor terminals T1,T2,T3 and drive terminals U, V & W matching), the drive will provide correct phase supply to the compressor, and reverse rotation will be not possible:For more details refer to [Motor protection](#).
- Voltage and voltage unbalance within tolerance: For more details refer to section [Supply voltage](#).

Initial start-up

- Crankcase heaters must be energized at least 6 hours in advance to remove refrigerant.
- Do not provide any power to the drive unless suction and discharge service valves on compressor are open, if installed.
- Energize the drive. The compressor must start, according to defined ramp-up settings. If the compressor does not start, check wiring conformity.
- Check the frequency converter control panel: If any alarm is displayed check the wiring and in particular the polarity of the control cables.If an alarm is shown, refer to the frequency converter application manual. Verify in particular the combination of compressor, frequency converter and refrigerant.
- Check current draw and voltage levels on the mains. The values for the compressor electrical motor can be directly displayed on the frequency converter control panel.

System monitoring

The system must be monitored after initial startup for a minimum of 60 minutes to ensure proper operating characteristics such as:

- Proper metering device operation and desired superheat readings
- Suction and discharge pressure are within acceptable levels
- Surface sump heaters must be energized at least 6 hours in advance to remove refrigerant.
- Correct oil level in compressor sump indicates proper oil return
- Low foaming in sight glass and compressor sump temperature above 7K saturation temperature to show that there is no refrigerant migration taking place
- Current draw of compressor within acceptable values (RLA ratings)
- No abnormal vibrations and noise.

Oil level checking and top-up

In installations with good oil return and line runs up to 15m (49.2 feet), no additional oil is required. If installation lines exceed 15m (49.2 feet), additional oil may be needed. 3% of the total system refrigerant charge (in kg/lb) can be used to roughly define the required oil top-up quantity (in liters) but in any case the oil charge has to be adjusted based on the oil level in the compressor sight glass.

When the compressor is running under stabilized conditions, the oil level must be visible in the sight glass.

The presence of foam filling in the sight glass indicates large concentration of refrigerant in the oil and / or presence of liquid returning to the compressor.

The oil level can also be checked a few minutes after the compressor stops, the level must be visible in sight glass.

When the compressor is off, the level in the sight glass can be influenced by the presence of refrigerant in the oil.

Top-up the oil while the compressor is idle. Use the schrader connector or any other accessible connector on the compressor suction line and a suitable pump.

Dismantle and disposal



Danfoss recommends that compressors and compressor oil should be recycled by a suitable company at its site.

Packaging

Single pack



Table 52: Single pack

Compressor model	Height	Width	Depth	Weight
	(mm)	(mm)	(mm)	(mm)
VZH088	718	565	470	70
VZH117	718	565	470	76
VZH170	765	515	450	112

Industrial pack



Table 53: Industrial pack

Compressor model	Number	Height	Width	Depth	Gross Weight	Static stacking pallets
		(mm)	(mm)	(mm)	(mm)	
VZH088	8	1150	950	680	494	2
VZH117	8	1150	950	750	544	2
VZH170	4	1150	965	768	647	2

Frequency converter single pack

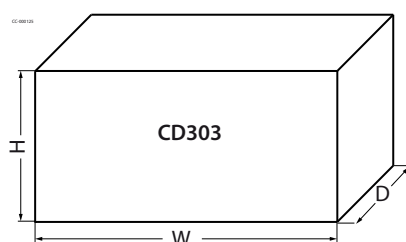

Table 54: Frequency converter single pack

Drive supply voltage	Drive power (kW)	IP20				IP55			
		Height (H)	Width (W)	Depth (D)	Weight	Height (H)	Width (W)	Depth (D)	Weight
		(mm)	(mm)	(mm)	(Kg)	(mm)	(mm)	(mm)	(Kg)
T2: Code J	15	346	810	320	24	430	805	405	46
	18-22	437	805	405	36	437	805	405	46
T4: Code G	15	349	500	330	13	346	810	320	24
	18-22	346	810	320	24	346	810	320	28
T6: code H	18.5-30	346	810	320	24	-	-	-	-

Ordering

Danfoss scroll compressors VZH can be ordered in either industrial packs or in single packs. Drive can be ordered in single packs. Please use the code numbers from below tables for ordering.

Single pack

Table 55: Single pack

Compressor model	Equipment version	Technical Name	X = motor code		
			G	J	H
			380-480V/3ph/ 50&60Hz	200-240V/3ph/ 50&60Hz	525-600V/3ph/ 50&60Hz
VZH088	Single	VZH088CXANA	120G0189	120G0190	120G0191
VZH088	Unified	VZH088CXDNA	120G0192	120G0193	120G0194
VZH117	Single	VZH117CXANA	120G0195	120G0196	120G0197
VZH117	Unified	VZH117CXDNA	120G0198	120G0199	120G0200
VZH170	Single	VZH170CXANA	120G0201	120G0203	120G0204
VZH170	Unified	VZH170CXDNA	120G0205	120G0206	120G0207

Industrial pack

Table 56: Industrial pack

Compressor model	Equipment version	Technical Name	X = motor code	
			G	J
			380-480V/3ph/ 50&60Hz	200-240V/3ph/ 50&60Hz
VZH088	Single	VZH088CXANA	120G0222	120G0223
VZH088	Unified	VZH088CXDNA	120G0224	120G0225
VZH117	Single	VZH117CXANA	120G0226	120G0227
VZH117	Unified	VZH117CXDNA	120G0228	120G0229
VZH170	Single	VZH170CXANA	120G0230	120G0231
VZH170	Unified	VZH170CXDNA	120G0232	120G0233

Coils

Table 57: Coils

Coil model	Code no.
208V-240V coil + adaptor	120Z0521
24V coil + adaptor	120Z0522

VZH voltage code G - 380-480 Volt

Compressor model	Frequency converter					Code no. for ordering
	Model	power	IP class	RFI class	Coating	
VZH088-G	CDS303	15.0kW	IP20	H3	No	134G3576
					Yes	134G3577
				H2	No	134F9366
					Yes	134G3578
			IP55	H3	No	134G4008
					Yes	134G4010
				H2	No	134G4012
					Yes	134G4013
VZH117-G	CDS303	18.5kW	IP20	H3	No	134G3579
					Yes	134G3580
				H2	No	134F9368
					Yes	134G3581
			IP55	H3	No	134G4015
					Yes	134G4016
				H2	No	134G4018
					Yes	134G4019

Compressor model	Frequency converter					Code no. for ordering
	Model	power	IP class	RFI class	Coating	
VZH170-G	CDS303	22.0kW	IP20	H3	No	134G3582
					Yes	134G3583
				H2	No	134F9371
					Yes	134G3584
			IP55	H3	No	134G4020
					Yes	134G4021
				H2	No	134G4022
					Yes	134G4023

VZH voltage code H - 525-600 Volt

Compressor model	Frequency converter					Code no. for ordering
	Model	power	IP class	RFI class		
VZH088-H	CDS303	18.5kW	IP20	HX		134L7237
VZH117-H	CDS303	30kW	IP20	HX		134L7239
VZH170-H	CDS303	30kW	IP20	HX		134L7239

VZH voltage code J - 200-240 Volt

Compressor model	Frequency converter					Code no. for ordering
	Model	power	IP class	RFI class	Coating	
VZH088-J	CDS303	15.0kW	IP20	H3	No	134G3474
					Yes	134F9361
				IP55	H3	No
			H2			No
			IP20		H3	No
				H2		No
IP55	H3	No		134G4003		
		H2	No	134G4004		
	VZH117-J	CDS303	18.5kW	IP20	H3	No
Yes						134X1965
IP55					H3	No
				H2		No
				IP20	H2	No
Yes						134X1966
IP55	H3	No	134G4005			
		H2	No	134G4006		

i NOTE:

LCP: user interface 120Z0326 (accessory)

Accessories and Spare parts

Solder sleeve adapter sets - Valves, adapters, connectors & gaskets for use on suction and discharge connections

Code no.	Description	Application	Packaging	Pack size
120Z0125	Solder sleeve adapter set (1"3/4 Rotolock, 1"1/8 ODF), (1"1/4 Rotolock, 7/8" ODF)	VZH088	Multipack	8
120Z0405	Solder sleeve adapter set (1"3/4 Rotolock, 1"3/8 ODF), (1"1/4 Rotolock, 7/8" ODF)	VZH117	Multipack	8
7765028	Solder sleeve adapter set, (2"1/4 Rotolock, 1"5/8 ODF), (1"3/4 Rotolock, 1"1/8 ODF)	VZH170	Multipack	6

Surface sump heaters

Code no.	Description	Application	Packaging	Pack size
120Z0388	Surface sump heater, 80 W, 24 V, CE, UL	VZH088-117	Multipack	8
120Z0389	Surface sump heater, 80 W, 230 V, CE, UL	VZH088-117	Multipack	8
120Z0390	Surface sump heater, 80 W, 400 V, CE, UL	VZH088-117	Multipack	8

Code no.	Description	Application	Packaging	Pack size
120Z0391	Surface sump heater, 80 W, 460 V, CE, UL	VZH088-117	Multipack	8
120Z0402	Surface sump heater, 80 W, 575 V, CE, UL	VZH088-117	Multipack	8
120Z0360	Surface sump heater + bottom insulation, 56 W, 24 V, CE, UL	VZH170	Multipack	6
120Z0376	Surface sump heater + bottom insulation, 56 W, 230 V, CE, UL	VZH170	Multipack	6
120Z0377	Surface sump heater + bottom insulation, 56 W, 400 V, CE, UL	VZH170	Multipack	6
120Z0378	Surface sump heater + bottom insulation, 56 W, 460 V, CE, UL	VZH170	Multipack	6
120Z0379	Surface sump heater + bottom insulation, 56 W, 575 V, CE, UL	VZH170	Multipack	6

Discharge thermostats and sensors

Code no.	Description	Application	Packaging	Pack size
120Z0157	Discharge temperature sensor / converter kit	VZH all models	Single pack	1
120Z0158	Discharge temperature sensor	VZH all models	Single pack	1
120Z0159	Discharge temperature converter	VZH all models	Single pack	1
7750009	Discharge thermostat kit	VZH all models	Multipack	10

Acoustic hoods - Lubricant, acoustic hoods and spare parts

Code no.	Description	Application	Packaging	Pack size
120Z0509	VZH088-G acoustic hood	VZH088-G/H	Single pack	1
120Z0510	VZH088-J acoustic hood	VZH088-J	Single pack	1
120Z0511	VZH088-G manifolding acoustic hood	VZH088-G/H manifolding	Single pack	1
120Z0512	VZH088-J manifolding acoustic hood	VZH088-J manifolding	Single pack	1
120Z0513	VZH117-G acoustic hood	VZH117-G/H	Single pack	1
120Z0514	VZH117-J acoustic hood	VZH117-J	Single pack	1
120Z0515	VZH117-G manifolding acoustic hood	VZH117-G/H manifolding	Single pack	1
120Z0516	VZH117-J manifolding acoustic hood	VZH117-J manifolding	Single pack	1
120Z0517	VZH170-G acoustic hood	VZH170-G/H	Single pack	1
120Z0519	VZH170-J acoustic hood	VZH170-J	Single pack	1
120Z0518	VZH170-G manifolding acoustic hood	VZH170-G/H manifolding	Single pack	1
120Z0520	VZH170-J manifolding acoustic hood	VZH170-J manifolding	Single pack	1

Oil sight glass

Code no.	Description	Application	Packaging	Pack size
120Z0700	Oil sight glass for unified version	VZH088/117 unified version	Single pack	1
120Z0701	Oil sight glass for unified version	VZH170 unified version	Single pack	1

Mounting kits

Code no.	Description	Application	Packaging	Pack size
120Z0066	Mounting kit for 1 scroll compressor including 4 grommets, 4 sleeves, 4 bolts, 4 washers	VZH088-117	Single pack	1
8156138	Mounting kit for 1 scroll compressor including 4 grommets, 4 sleeves, 4 bolts, 4 washers	VZH170	Single pack	1

Terminal boxes, covers & T-block connectors

Code no.	Description	Application	Packaging	Pack size
8173230	T block connector 52 x 57 mm	VZH088-G/H, VZH117-G/H	Multipack	10
8173021	T block connector 60 x 75 mm	VZH088-J.VZH117-J.VZH170-G/H	Multipack	10
8173331	T block connector 80 x 80 mm	VZH170-J	Multipack	10
120Z0146	Electrical box	VZH088-G/H.VZH117-G/H	Single pack	1
120Z0147	Electrical box	VZH170-J	Single pack	1
120Z0538	Electrical box	VZH170-G/H	Single pack	1
120Z0149	Electrical box cover	VZH088-G/H.VZH117-G/H	Single pack	1

Code no.	Description	Application	Packaging	Pack size
120Z0150	Electrical box cover	VZH170-J	Single pack	1
120Z0537	Electrical box cover	VZH170-G/H	Single pack	1
120Z0151	Electrical box cover	VZH088-117-J	Single pack	1

Coil

Code no.	Description	Application	Packaging	Pack size
120Z0521	Coil / 208-240V and adaptor	VZH all models	Single pack	1
120Z0522	Coil / 24V and adaptor	VZH all models	Single pack	1
042N4202	Coil 110-120V	VZH all models	Single pack	1
042N0156	Adaptor	VZH all models	Single pack	1

Valve Body

Code no.	Description	Application	Packaging	Pack size
120Z0145	Valve body	VZH all models	Single pack	1

Lubricant / oils

Type	Code no.	Description	Application	Packaging	Pack size
160SZ	7754023	POE lubricant, 160SZ, 1 litre can	VZH with R410A	Multipack	12

Oil level switch

Code no.	Description	Application	Packaging	Pack size
120Z0560	Oil level switch screw in- mechanical part	All models	Single pack	1
120Z0561	Oil level switch - electrical part (24V AC/DC)	All models	Single pack	1
120Z0562	Oil level switch - electrical part (230V AC)	All models	Single pack	1

LCP's Spare parts frequency converter

Code no.	Description	Application	Packaging	Pack size
120Z0326	LCP display	Frequency converter / all models	Single pack	1
175Z0929	RS cable to LCP	Frequency converter / all models	Single pack	1
130B0264	LCP cradle, required to mount the LCP on IP55 casings	Frequency converter / all models	Single pack	1

Fans

Code no.	Description	Application	Packaging	Pack size
130B3406	Fan IP55	VZH117 G & J	Single pack	1

Control card

Code no.	Description	Application	Packaging	Pack size
130B5667	Control card	Frequency converter / all models	Single pack	1

Accessory bags

Code no.	Description	Application	Packaging	Pack size
130B1300	Accessory bag IP20	VZH088-J, VZH117-G, VZH170-G	Single pack	1
130B0980	Accessory bag IP20	VZH088-G	Single pack	1

Relays card

Code no.	Description	Application	Packaging	Pack size
120Z0350	Relays card	Frequency converter	Single pack	1

Brackets

Code no.	Description	Application	Packaging	Pack size
120Z0642	16AC bracket for VZH088/117 CDS303 drives	Frequency converter	Single pack	1
120Z0643	20AC bracket for VZH088/117 CDS303 drives	Frequency converter	Single pack	1

Online support

Danfoss offers a wide range of support along with our products, including digital product information, software, mobile apps, and expert guidance. See the possibilities below.

The Danfoss Product Store



The Danfoss Product Store is your one-stop shop for everything product related—no matter where you are in the world or what area of the cooling industry you work in. Get quick access to essential information like product specs, code numbers, technical documentation, certifications, accessories, and more.

Start browsing at store.danfoss.com.

Find technical documentation



Find the technical documentation you need to get your project up and running. Get direct access to our official collection of data sheets, certificates and declarations, manuals and guides, 3D models and drawings, case stories, brochures, and much more.

Start searching now at www.danfoss.com/en/service-and-support/documentation.

Danfoss Learning



Danfoss Learning is a free online learning platform. It features courses and materials specifically designed to help engineers, installers, service technicians, and wholesalers better understand the products, applications, industry topics, and trends that will help you do your job better.

Create your Danfoss Learning account for free at www.danfoss.com/en/service-and-support/learning.

Get local information and support



Local Danfoss websites are the main sources for help and information about our company and products. Find product availability, get the latest regional news, or connect with a nearby expert—all in your own language.

Find your local Danfoss website here: www.danfoss.com/en/choose-region.

Coolselector®2 - find the best components for you HVAC/R system



Coolselector®2 makes it easy for engineers, consultants, and designers to find and order the best components for refrigeration and air conditioning systems. Run calculations based on your operating conditions and then choose the best setup for your system design.

Download Coolselector®2 for free at coolselector.danfoss.com.

Ref Tools – essential tools for HVACR professionals



Get the guidance, support, information, and tools you need—on the job and in field. Ref Tools is a free, powerful app that contains essential tools every air conditioning and refrigeration technician needs in their digital toolbelt.

Download Ref Tools for free at coolapps.danfoss.com

Danfoss can accept no responsibility for possible errors in catalogues, brochures and other printed material. Danfoss reserves the right to alter its products without notice. This also applies to products already on order provided that such alterations can be made without subsequential changes being necessary in specifications already agreed. All trademarks in this material are property of the respective companies. Danfoss and the Danfoss logotype are trademarks of Danfoss A/S. All rights reserved.